

Power Breakers, Contactors and Fuses Family



<b>26.1 Power Circuit Breakers</b>	
Low Voltage Power Circuit Breakers . . . . .	<b>V4-T26-2</b>
Magnum DS Low Voltage Power Circuit Breakers . . . . .	<b>V4-T26-6</b>
Magnum MDSL Current Limiting Power Circuit Breaker . . . . .	<b>V4-T26-11</b>
Magnum SB Low Voltage Insulated Case Circuit Breakers . . . . .	<b>V4-T26-14</b>
Magnum IEC Rated Air Circuit Breakers . . . . .	<b>V4-T26-18</b>
Series NRX Low Voltage Power Circuit Breakers . . . . .	<b>V4-T26-27</b>
Medium Voltage Circuit Breakers . . . . .	<b>V4-T26-34</b>
<b>26.2 Medium Voltage Power Contactors</b>	
Product Overview . . . . .	<b>V4-T26-51</b>
SL MV Power Contactor 7.2 kV/160–400A . . . . .	<b>V4-T26-53</b>
SL MV Power Contactor 7.2 kV/800A . . . . .	<b>V4-T26-62</b>
SL MV Power Contactor 15 kV/250A . . . . .	<b>V4-T26-66</b>
<b>26.3 Fuses General</b>	
Product Overview . . . . .	<b>V4-T26-70</b>
Power Fuse . . . . .	<b>V4-T26-70</b>
Power vs. Distribution . . . . .	<b>V4-T26-70</b>
Low vs. Medium vs. High Voltage . . . . .	<b>V4-T26-70</b>
Expulsion vs. Current Limiting (Definitions per ANSI C47.40-1993) . . . . .	<b>V4-T26-71</b>
Fuse Types . . . . .	<b>V4-T26-71</b>
General Fuse Component Terms . . . . .	<b>V4-T26-71</b>
<b>26.4 Expulsion Fuses</b>	
Product Description . . . . .	<b>V4-T26-73</b>
Accessories . . . . .	<b>V4-T26-73</b>
Catalog Number Selection . . . . .	<b>V4-T26-74</b>
Product Selection . . . . .	<b>V4-T26-75</b>
<b>26.5 Current Limiting Fuses</b>	
Catalog Number Selection . . . . .	<b>V4-T26-94</b>
Product Selection . . . . .	<b>V4-T26-96</b>

Power Circuit Breaker



### Contents

<i>Description</i>	<i>Page</i>
Low Voltage Power Circuit Breakers Features, Benefits and Functions . . . . .	<b>V4-T26-3</b>
Magnum DS Low Voltage Power Circuit Breakers . . . . .	<b>V4-T26-6</b>
Magnum MDSL Current Limiting Power Circuit Breaker . . . . .	<b>V4-T26-11</b>
Magnum SB Low Voltage Insulated Case Circuit Breakers . . . . .	<b>V4-T26-14</b>
Magnum IEC Rated Air Circuit Breakers . . . . .	<b>V4-T26-18</b>
Series NRX Low Voltage Power Circuit Breakers . . . . .	<b>V4-T26-27</b>
Medium Voltage Circuit Breakers . . . . .	<b>V4-T26-34</b>

## Low Voltage Power Circuit Breakers

### Product Overview

#### **Magnum Low Voltage Power Circuit Breakers for Global Application**

Magnum™ Low Voltage Power Circuit Breakers enable comprehensive solutions to meet and exceed the unique and wide-ranging requirements of today's global power distribution systems. This powerful circuit breaker offering is designed for ultimate custom configuration and application flexibility, with the needs of the power distribution equipment user and the electrical equipment manufacturer in mind.

#### **Three Product Families**

Magnum consists of three product families; each provides specific ratings features and approvals to optimize performance when applied in power distribution equipment and custom enclosures:

#### **Magnum DS Low Voltage Power Circuit Breakers for ANSI Rated Switchgear Applications**

- Up to 635 Vac
- 200 to 6000A continuous
- 42 to 200 kA interrupting



**Magnum DS Low Voltage Power Circuit Breaker Family ANSI Rated for Switchgear Applications**

#### **Magnum SB Low Voltage Insulated Case Circuit Breakers for Switchboard Applications**

- Up to 635 Vac
- 200 to 5000A continuous
- 50 to 150 kA interrupting



**Magnum SB Low Voltage Insulated Case Circuit Breaker Family UL Rated for Switchboard Applications**

#### **Magnum IEC Air Circuit Breakers for IEC Rated Switchboards**

- Up to 690 Vac
- 200 to 6300A continuous
- 40 to 105 kA  $I_{cu}/I_{cs}$



**Magnum IEC Low Voltage Air Circuit Breaker Family**

**Features, Benefits and Functions**

- **200 kA interruption ratings** with current limiting performance and low current let-through to reduce damaging energy to downstream equipment at high fault levels
- **Withstand ratings up to 100 kA** to maximize system coordination and selectivity
- **Four physical frame sizes** (Narrow, Standard, Double Narrow and Double) to promote breaker application in compact modular enclosures and improve enclosure density
- **Continuous current ratings from 800 to 6300A** with 100% rating at 104°F (40°C) and no derating on most ratings up to 122°F (50°C)
- **Fixed breaker mounting configurations** with horizontal and optional vertical and front connected terminal connections
- **Drawout breaker mounting configurations** with cassette and optional safety shutters
- **Three- and four-pole breaker configurations**
- **Through-the-door design** for human interface with the breaker compartment door closed
- **Two-step stored energy mechanism** for manually and electrical operated breakers
- **Digitrip™ RMS Trip Unit family protection** with four models each providing increasing levels of protection and feature options for coordination, information and diagnostics:
  - Microprocessor-based rms sensing
  - Basic to programmable overcurrent protection and alarms
  - Local display for information, status and diagnostics
  - Ampere, voltage and power metering
  - Power quality, harmonics and waveform capture
  - Communications with translators to common protocols
  - Zone selective interlocking for improved coordination
  - Integral Arcflash Reduction Maintenance System™
  - Breaker health monitoring
- **Field-installable accessories** (UL® listed) common across the breaker frames and designed to be easily installed in the field to service or modify the breaker at the point of use
- **Secondary terminal contacts** mounted at the top front of the breaker and away from the primary voltage areas for improved safety and access. Finger-safe terminal blocks accommodate ring-tongue or spade type terminals as standard



*Through-the-Door Design for Human Interface with the Breaker Compartment Door Closed*



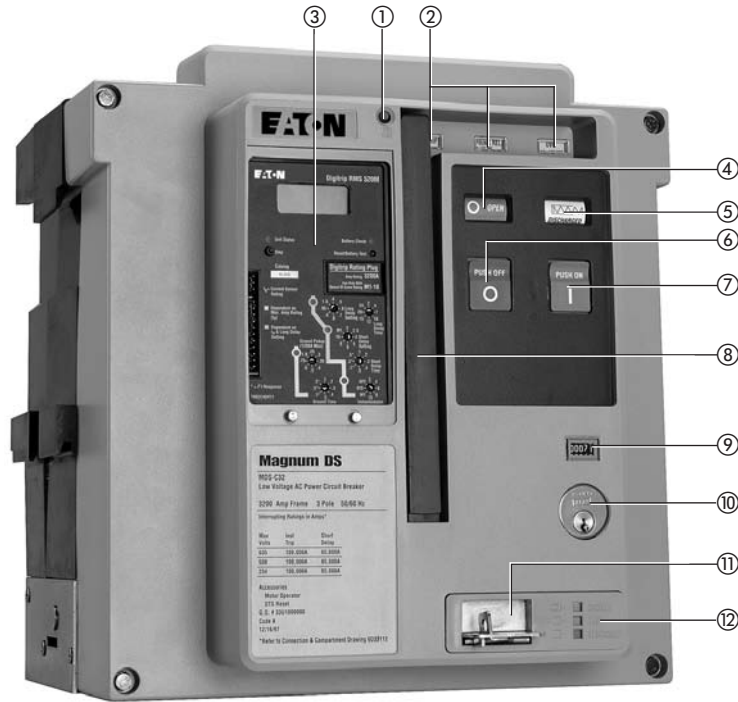
*High Technology Microprocessor-Based Digitrip RMS 1150+ Trip Units are Available With Advanced Features Like Programmable Overcurrent Settings, Power Metering, Power Quality and Communications*

#### Breaker Features on Front Cover

The controls and indicators are functionally grouped on the breaker faceplate to optimize the human interface, visibility and ease of use. For maximum safety, a modern, through-the-door design permits access to the breaker levering system, trip unit, controls and indicators with the door closed.

- ① Red Mechanical Trip Flag Pop-out Indicator (Optional)—Interlocked Indicator Requiring Manual Reset is also Available
- ② Accessory Viewing Windows for:
  - Shunt Trip Attachment (STA)
  - Spring Release Device (SR)
  - Undervoltage Release (UVR) Device or Second STA
- ③ Digitrip RMS Trip Unit (Model 520M Shown) Protected by Clear Cover
- ④ Contact Status Indicators:
  - OPEN—Green
  - CLOSED—Red
- ⑤ Spring Status Indicators:
  - Charged—Yellow
  - Discharged—White
- ⑥ Push OFF (Open) Pushbutton—Red
- ⑦ Push ON (Close) Pushbutton—Green
- ⑧ Manual Spring Charging Handle for Manually Charging the Stored Energy Springs
- ⑨ Mechanical Operations Counter (Optional)
- ⑩ Key Off Lock (Optional)
- ⑪ Padlockable Levering Device Shutter for Drawout Breakers
- ⑫ Color-Coded Position Indicator for Drawout Breakers:
  - CONNECT—Red
  - TEST—Yellow
  - DISCONNECT—Green

#### Magnum DS Drawout Breaker



**Accessory Viewing Windows Visibly Confirm the Breaker Shunt Trip, Spring Release, and UVR Installation and Their Control Voltage Rating**



**Through-the-Door Design for Human Interface with the Breaker Compartment Door Closed, for Example, Manually Charging the Stored Energy Springs**



**Drawout Breaker Levering Can be Accomplished With the Compartment Door Closed Without the Need for a Special Levering Tool**

**Breaker Internal Features**

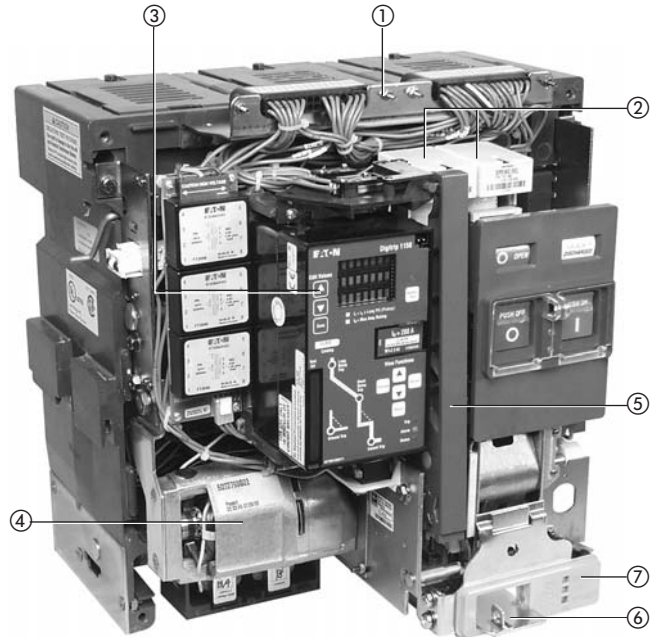
Magnum is designed for ease of access for inspection, modification and maintenance at the point of use. The breaker front cover is easily removed with four captive bolts, revealing the modular internal breaker features.

- ① Secondary Terminal Points for Internal Breaker Wiring Connections
- ② Breaker Accessory Mounting Deck with Three Positions for Mounting:
  - Shunt Trip Attachment (STA)
  - Spring Release Device (SR)
  - Undervoltage Release (UVR) Device or Second STA
- ③ Digitrip RMS Trip Unit (Model 1150+ Shown)
- ④ Spring Charging Motor (Optional) for Electrically Charging the Stored Energy Springs
- ⑤ Manual Spring Charging Handle for Manually Charging the Stored Energy Springs

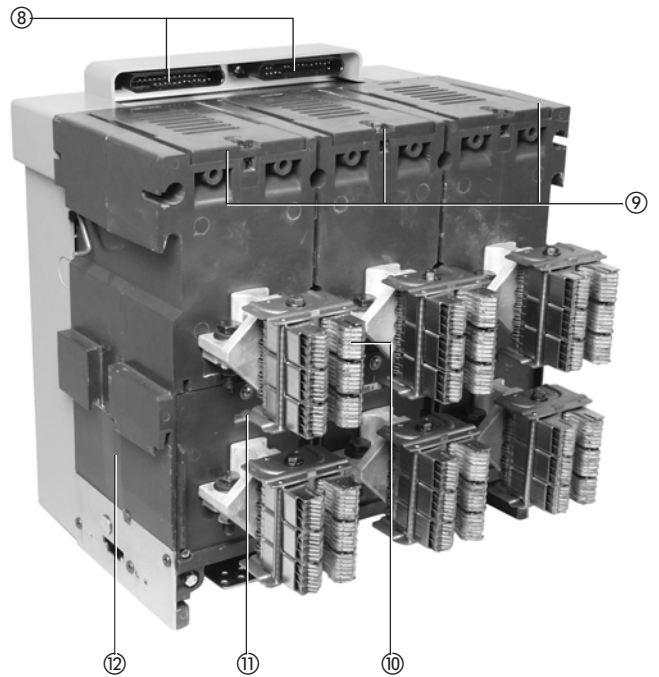
- ⑥ Padlockable Levering Device Shutter for Drawout Breakers
- ⑦ Color-Coded Position Indicator for Drawout Breakers:
  - CONNECT—Red
  - TEST—Yellow
  - DISCONNECT—Green
- ⑧ Secondary Contact Blocks for Connection to External Cell Control Wiring
- ⑨ Removable Arc Chute Covers for Easy Access to Breaker Main Contacts
- ⑩ Primary Finger Cluster Disconnecting Contacts for Drawout Breaker are Mounted on the Breaker Element (Not in the Breaker Compartment) for Ease of Access for Inspection and Maintenance

**Note:** Some competitors mount the primary finger clusters inside the cell, requiring shutdown of the switchgear for inspection and maintenance.

- ⑪ Current Sensor Viewing Windows to View and Confirm Breaker Sensor Rating
- ⑫ Rigid Frame Housing (Thermoset Composite Resin) Providing Increased Strength and Durability



**Magnum Drawout Breaker Front View With Front Cover Removed Showing Easy Access to the Breaker Internal Devices**



**Magnum Drawout Breaker Rear View Showing Primary Disconnecting Finger Clusters Mounted on the Breaker for Ease of Inspection**



#### Magnum DS, MDSX and MDSL Circuit Breakers



### Magnum DS Low Voltage Power Circuit Breakers

#### Product Description

Magnum DS is a true UL 1066 listed low voltage power circuit breaker family, designed for the highest performance requirements of switchgear and specialty enclosure applications.

- Magnum DS Low Voltage Power Circuit Breakers have interrupting ratings up to 200 kA at 480 Vac, and short-time withstand ratings up to 100 kA at 635 Vac with continuous current ratings up to 6000A to maximize system coordination and selectivity
- Magnum MDSX Current Limiting Power Circuit Breakers have 200 kA interrupting ratings at 480 Vac with continuous current ratings up to 5000A
- Magnum MDSL Current Limiting Power Circuit Breakers have 200 kA interrupting ratings at 600 Vac with continuous current ratings up to 2000A



*The Magnum MDSL Current Limiting Power Circuit Breakers have integral current limiters to provide interrupting ratings of 200 kA at 600 Vac.*



*The Magnum MDSX Current Limiting Power Circuit Breakers have fast opening contacts to provide interrupting ratings up to 200 kA at 480 Vac without fuses.*

### Contents

<b>Description</b>	<b>Page</b>
Low Voltage Power Circuit Breakers . . . . .	<b>V4-T26-2</b>
Magnum DS Low Voltage Power Circuit Breakers	
Catalog Number Selection . . . . .	<b>V4-T26-7</b>
Technical Data and Specifications . . . . .	<b>V4-T26-10</b>
Magnum MDSL Current Limiting Power Circuit Breaker . . . . .	<b>V4-T26-11</b>
Magnum SB Low Voltage Insulated Case Circuit Breakers . . . . .	<b>V4-T26-14</b>
Magnum IEC Rated Air Circuit Breakers . . . . .	<b>V4-T26-18</b>
Series NRX Low Voltage Power Circuit Breakers . . . . .	<b>V4-T26-27</b>
Medium Voltage Circuit Breakers . . . . .	<b>V4-T26-34</b>

### Standards and Certifications

#### UL and ANSI Test Certifications

Magnum DS meets or exceeds the applicable ANSI, NEMA®, UL and CSA® standards, including:

- ANSI C37.13 (Low Voltage AC Power Circuit Breakers Used in Enclosures)
- ANSI C37.16 (Preferred Ratings, Related Requirements, and Application Recommendations for Low Voltage Power Circuit Breakers and AC Power Circuit Breakers)
- ANSI C37.17 (Trip Devices for AC and General Purpose DC Low Voltage Power Circuit Breakers)
- ANSI C37.50 (Test Procedures for Low Voltage AC Power Circuit Breakers Used in Enclosures)
- UL 1066 (Standard for Low Voltage AC and DC Power Circuit Breakers Used in Enclosures)
- NEMA SG3 (This standard adopts ANSI C37.16 in its entirety)

and switchboards with the following test certifications:

- UL 1558 (Certified Magnum DS Low Voltage Metal-Enclosed Switchgear)
- UL 891 (Certified Pow-R-Line C™ Low Voltage Switchboards)
- UL 1008 Standard for Transfer Switch Equipment
- UL, CSA 22.2.31 Low Voltage Assemblies

#### Approvals and Marks

- UL listed: Magnum DS Breaker UL File No. E52096 and Cassette UL File No. E204565
- ABS (American Bureau of Shipping) Type Listed Certificate Number 04-HS422844A-DUB
- Additional Magnum DS approvals and certificates can be found on [www.eaton.com](http://www.eaton.com)



#### Product Selection

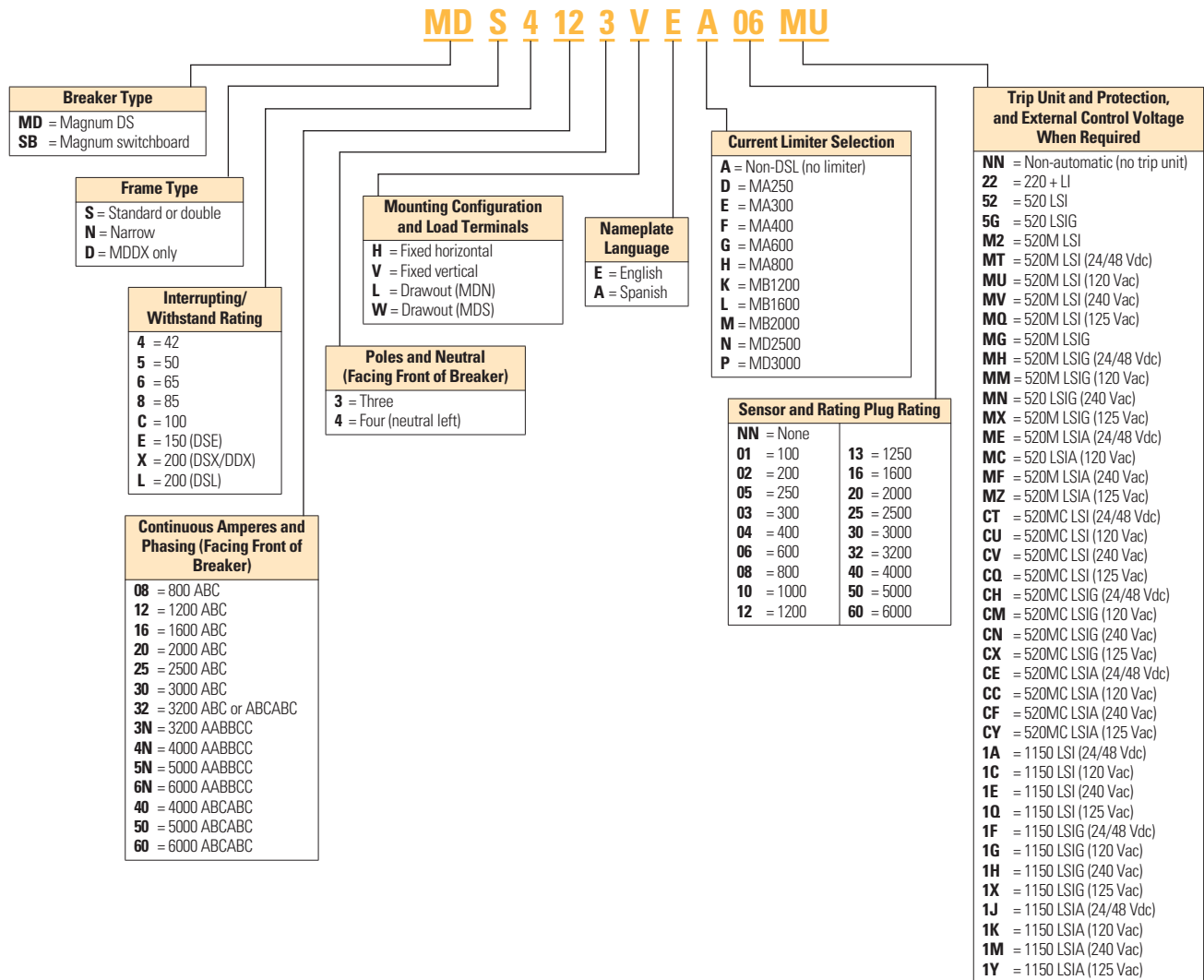
Contact Eaton for pricing.

#### Comprehensive Enclosure Solutions

Magnum DS has proven performance in Eaton manufactured switchgear

Catalog Number Selection

Magnum DS ANSI Breaker Product Family



# 26.1

## Power Breakers, Contactors and Fuses

### Power Circuit Breakers

#### Magnum DS ANSI Breaker Product Family, continued

26

**A W C H N E H K L A X**

**Shunt Trip (ST)**

**N** = None  
**A** = 110–127 Vac/Vdc  
**R** = 208–240 Vac/Vdc  
**C** = 24 Vdc  
**H** = 48 Vdc  
**B** = 110–127 Vac/Vdc (100% duty)  
**S** = 220–250 Vac/Vdc (100% duty)  
**D** = 24 Vdc (100% duty)  
**K** = 48 Vdc (100% duty)  
**J** = 60 Vdc (100% duty)  
**6** = 60 Vdc

**Motor Operator**

**M** = Manual operated  
**N** = 110–125 Vac (5-sec)  
**W** = 110–125 Vdc (5-sec)  
**T** = 220–250 Vdc (5-sec)  
**P** = 220–240 Vac (5-sec)  
**L** = 24 Vdc (5-sec)  
**K** = 48 Vdc (5-sec)  
**S** = 60 Vdc (5-sec)

**Spring Release Device (SRD)**

**N** = None  
**A** = 110–127 Vac/Vdc  
**R** = 208–240 Vac/Vdc  
**C** = 24 Vdc  
**H** = 48 Vdc  
**S** = 60 Vdc

**Undervoltage Release (UVR) or 2nd Shunt Trip (ST)**

**N** = None  
**A** = UVR (110–127 Vac)  
**R** = UVR (208–240 Vac)  
**C** = UVR (24 Vdc)  
**H** = UVR (48 Vdc)  
**D** = UVR (60 Vdc)  
**E** = UVR (110–125 Vdc)  
**F** = UVR (220–250 Vdc)  
**G** = UVR (32 Vdc)  
**X** = UVR (380–415 Vac)  
**J** = UVR (480 Vac)  
**K** = UVR (600 Vac)  
**1** = 2nd ST (110–127 Vac/Vdc)  
**2** = 2nd ST (208–250 Vac/Vdc)  
**3** = 2nd ST (24 Vdc)  
**4** = 2nd ST (48 Vdc)  
**6** = 2nd ST (60 Vdc)  
**B** = 2nd ST (110–127 Vac/Vdc 100% duty)  
**O** = 2nd ST (220–250 Vac/Vdc 100% duty)  
**I** = 2nd ST (24 Vdc 100% duty)  
**Q** = 2nd ST (48 Vdc 100% duty)  
**9** = 2nd ST (60 Vdc 100% duty)

**Auxiliary Switch**

**N** = None  
**2** = 2A/2B  
**4** = 4A/4B  
**6** = 6A/6B

**Bell Alarms Switch (OTS) with 2a/2b Contacts and/or Mechanical Trip Indicator**

OTS 2a/2b	Trip Indicator
<b>E</b> = No OTS	No indicator
<b>N</b> = No OTS	With indicator
<b>Y</b> = With OTS	With indicator
<b>M</b> = No OTS	With interlocked indicator
<b>L</b> = With OTS	With interlocked indicator

**Padlock Provisions for Blocking Close and/or Open ACB Manual Pushbuttons**

**N** = None  
**M** = Metal (block close and open)  
**P** = Plastic (block close and open)  
**C** = Metal (block close only)  
**H** = Plastic (block close only)  
**S** = Metal swbd lock-off (block close, depress open)

**Operations Counter and/or Keylock Provisions**

	Counter	Keylock Provisions
<b>N</b> =	No counter	No locks
<b>K</b> =	No counter	Kirk lock
<b>C</b> =	No counter	Castell lock
<b>R</b> =	No counter	Ronis lock
<b>S</b> =	No counter	CES lock
<b>A</b> =	Counter	No lock
<b>Y</b> =	Counter	Kirk lock
<b>L</b> =	Counter	Castell lock
<b>H</b> =	Counter	Ronis lock indicator
<b>E</b> =	Counter	CES lock

**Latch Check Switch/Trip Unit Metering Voltage Connection for Digitrip 1150 Trip Unit**

	Latch Check Switch	1150 Voltage Connection
<b>N</b> =	None	Upper terminals
<b>M</b> =	None	Lower terminals
<b>L</b> =	LCS wired to SRD	Upper terminals
<b>Y</b> =	LCS Wired to SRD	Lower terminals
<b>C</b> =	LCS Wired External	Upper terminals
<b>D</b> =	LCS Wired External	Lower terminals

**Breaker Shipping Options and Instructions**

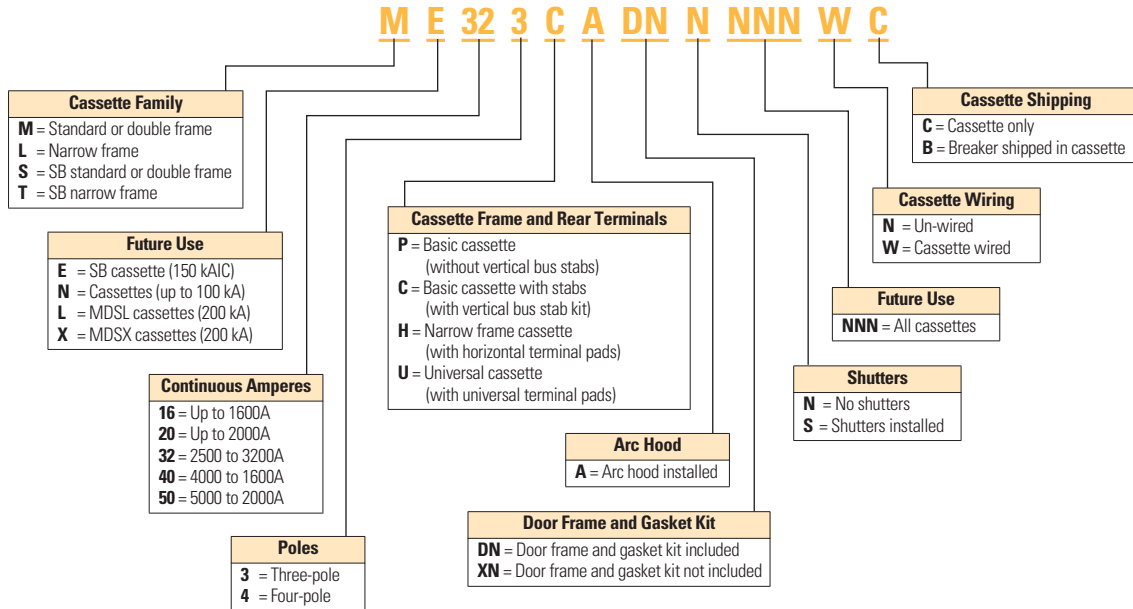
**A** = Fixed breaker alone with door kit  
**F** = Fixed breaker alone without door kit  
**A** = Drawout breaker alone without door frame kit  
**C** = Drawout breaker in cassette (un-wired)  
**P** = Drawout breaker in cassette (shutters)  
**S** = Drawout breaker in cassette (shutters)  
**W** = Drawout breaker in cassette (pre-wired and shutters)  
 Double frame drawout breakers ship without cassette drawout. ACBs ship in narrow and universal cassettes only.

**Frame Use**

**X** = All breakers



Cassette Magnum DS ANSI Breaker Product Family



## Technical Data and Specifications

## Magnum DS Switchgear Class UL 1066 Low Voltage Power Circuit Breakers

Frame Amperes	Breaker Type Catalog Position 1–6	Frame Type	rms Symmetrical Current Ratings kA 50/60 Hz <sup>①</sup>				Fixed Internal Instantaneous Trip	Available Current Sensor and Rating Plugs for Digitrip RMS Trip Unit (Establishes Breaker I <sub>n</sub> Rating)
			Interrupting at 254 Vac	Interrupting at 508 Vac	Interrupting at 635 Vac	Short-Time Withstand Rating		
800	MDN-408	Narrow	42	42	42	42	—	200, 250, 300, 400, 600, 800
	MDN-508	Narrow	50	50	50	50	—	
	MDN-608	Narrow	65	65	65	65	—	
	MDN-C08	Narrow	100	100	65	20	18 x I <sub>n</sub>	
	MDS-408	Standard	42	42	42	42	—	
	MDS-608	Standard	65	65	65	65	—	
	MDS-808	Standard	85	85	85	85	—	
	MDS-C08	Standard	100	100	100	85	85	
	MDS-L08 <sup>②</sup>	Standard	200	200	200	—	—	
MDS-X08 <sup>③</sup>	Standard	200	200	④	30	30		
1600	MDN-416	Narrow	42	42	42	42	—	200, 250, 300, 400, 600, 800, 1000, 1200, 1600
	MDN-516	Narrow	50	50	50	50	—	
	MDN-616	Narrow	65	65	65	65	—	
	MDN-C16	Narrow	100	100	65	30	18 x I <sub>n</sub>	
	MDS-616	Standard	65	65	65	65	—	
	MDS-816	Standard	85	85	85	85	—	
	MDS-C16	Standard	100	100	100	85	85	
	MDS-L16 <sup>②</sup>	Standard	200	200	200	—	—	
	MDS-X16 <sup>③</sup>	Standard	200	200	④	30	30	
2000	MDN-620	Narrow	65	65	65	65	—	200, 250, 300, 400, 600, 800, 1000, 1200, 1600, 2000
	MDN-C20	Narrow	100	100	65	35	18 x I <sub>n</sub>	
	MDS-620	Standard	65	65	65	65	—	
	MDS-820	Standard	85	85	85	85	—	
	MDS-C20	Standard	100	100	100	85	85	
	MDS-L20 <sup>②</sup>	Standard	200	200	200	—	—	
	MDS-X20 <sup>③</sup>	Standard	200	200	④	30	30	
3200	MDS-632	Standard	65	65	65	65	—	200, 250, 300, 400, 600, 800, 1000, 1200, 1600, 2000, 2500, 3000, 3200
	MDS-832	Standard	85	85	85	85	—	
	MDS-C32	Standard	100	100	100	85	85	
	MDS-X32 <sup>③</sup>	Double	200	200	④	50	50	
4000	MDN-640	Double narrow	65	65	65	65	—	2000, 2500, 3200, 4000
	MDN-840	Double narrow	85	85	65	85	—	
	MDN-C40	Double narrow	100	100	65	100	—	
	MDS-840	Double	85	85	85	85	—	
	MDS-C40	Double	100	100	100	100	—	
	MDS-X40 <sup>③</sup>	Double	200	200	④	50	50	
	MDD-X40	Double	200	200	100	100	—	
5000	MDS-850	Double	85	85	85	85	—	2500, 3200, 4000, 5000
	MDS-C50	Double	100	100	100	100	—	
	MDS-X50 <sup>③⑤</sup>	Double	200	200	④	50	50	
	MDD-X50	Double	200	200	100	100	—	
6000	MDS-C60 <sup>⑤</sup>	Double	100	100	100	100	—	3200, 4000, 5000, 6000
	MDD-X60 <sup>⑤</sup>	Double	200	200	100	100	—	

## Notes

- ① Interrupting ratings shown based on breaker equipped with integral Digitrip RMS Trip Unit. Interruption ratings for non-automatic breakers are equal to the published short-time withstand rating. These interruption ratings are based on the standard duty cycle consisting of an open operation, a 15-second interval and a close-open operation, in succession, with delayed tripping in case of short-delay devices. The standard duty cycle for short-time ratings consists of maintaining the rated current for two periods of 1/2 seconds each, with a 15-second interval of zero current between the two periods.
- ② Magnum MDSL Current Limiting Power Circuit Breaker With Integral Current Limiters. Current Limiter selected determines short-time and fixed instantaneous trip rating. Maximum voltage rating is 600 Vac.
- ③ Magnum MDSX Current Limiting Power Circuit Breaker with fast opening contacts.
- ④ Product to be tested. Contact Eaton for product rating.
- ⑤ Breaker applied in a tested fan-cooled enclosure.

Magnum MDSL Current Limiting Power Circuit Breaker



**Contents**

<b>Description</b>	<b>Page</b>
Low Voltage Power Circuit Breakers . . . . .	V4-T26-2
Magnum DS Low Voltage Power Circuit Breakers . . . . .	V4-T26-6
Magnum MDSL Current Limiting Power Circuit Breaker	
Product Selection . . . . .	V4-T26-12
Technical Data and Specifications . . . . .	V4-T26-12
Trip Curve Charts . . . . .	V4-T26-13
Magnum SB Low Voltage Insulated Case Circuit Breakers . . . . .	V4-T26-14
Magnum IEC Rated Air Circuit Breakers . . . . .	V4-T26-18
Series NRX Low Voltage Power Circuit Breakers . . . . .	V4-T26-27
Medium Voltage Circuit Breakers . . . . .	V4-T26-34

**Magnum MDSL Current Limiting Power Circuit Breaker**

**Product Description**

The following curves illustrate the ratings, melting time-current characteristics and current limiting, or let-through characteristics, of limiters for Magnum Low Voltage Power Circuit Breakers.

The let-through current for a given limiter application is readily determined by extending a vertical line from the applicable maximum available symmetrical fault amperes at the bottom margin to the characteristic line for the particular limiter, and from this intersection extending a horizontal line to the left margin and reading the peak current. The withstand rating of any circuit elements protected by the limiters should be at least equal to this peak current.

It will be noted that the let-through current increases with the limiter size or ampere rating; in other words, the maximum current limiting effect is obtained with the smallest size. This effect is to be expected, since the resistance decreases as the rating increases. If the vertical line from the bottom margin as described in the previous paragraph does not intersect the limiter characteristic line,

the available system fault current is below the "threshold" current of that limiter, and it will offer no current limiting effect.

The current limiting principle is illustrated below:

$I_a$ = The Available Peak Fault Current

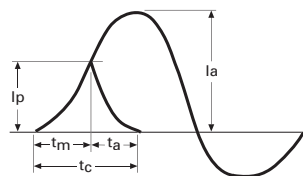
$t_m$ =The Melting Time

$I_p$ = The Peak Let-Through Current

$t_a$ = The Arcing Time

$t_c$ = The Total Interrupting (Clearing)Time

**Current Limiting**



**Limiter Selection**

The selection of a suitable limiter rating for a given application is generally governed by a choice of the following types of protection:

- A. Maximum protection of "downstream" components. Type MDSL breakers are often used for this purpose even when the maximum available fault currents are within the interrupting rating of the corresponding unfused Magnum breakers.
- B. Protection of the circuit breaker only.

Case A would tend to use the smallest available limiter; Case B the largest. When downstream protection is required, the selection is usually a compromise, since certain small limiters cannot be coordinated with the breaker to avoid nuisance blowing on overloads or small and moderate short circuits.

Minimum, recommended and maximum limiter sizes for Magnum MDSL breakers are given in the table on **Page V4-T26-12**.

## Product Selection

### Magnum MDSL Sensor/Rating Plug vs. Current Limiter Selection <sup>①</sup>

Sensor and Rating Plug  $I_n$  MDSL Current Limiter Selection Chart <sup>②</sup>

200	MA250	MA300	MA400	MA600 <sup>③</sup>	MA800	MB1200	MB1600	MB2000	MD2500	MD3000
250			MA400	MA600	MA800 <sup>③</sup>	MB1200	MB1600	MB2000	MD2500	MD3000
300			MA400	MA600	MA800 <sup>③</sup>	MB1200	MB1600	MB2000	MD2500	MD3000
400				MA600	MA800	MB1200 <sup>③</sup>	MB1600	MB2000	MD2500	MD3000
600					MA800	MB1200	MB1600	MB2000 <sup>③</sup>	MD2500	MD3000
800						MB1200	MB1600	MB2000	MD2500 <sup>③</sup>	MD3000
1000							MB1600	MB2000	MD2500 <sup>③</sup>	MD3000
1200								MB2000	MD2500 <sup>③</sup>	MD3000
1600										MD3000 <sup>③</sup>
2000										MD3000 <sup>③</sup>

## Technical Data and Specifications

### Magnum MDSL Ratings

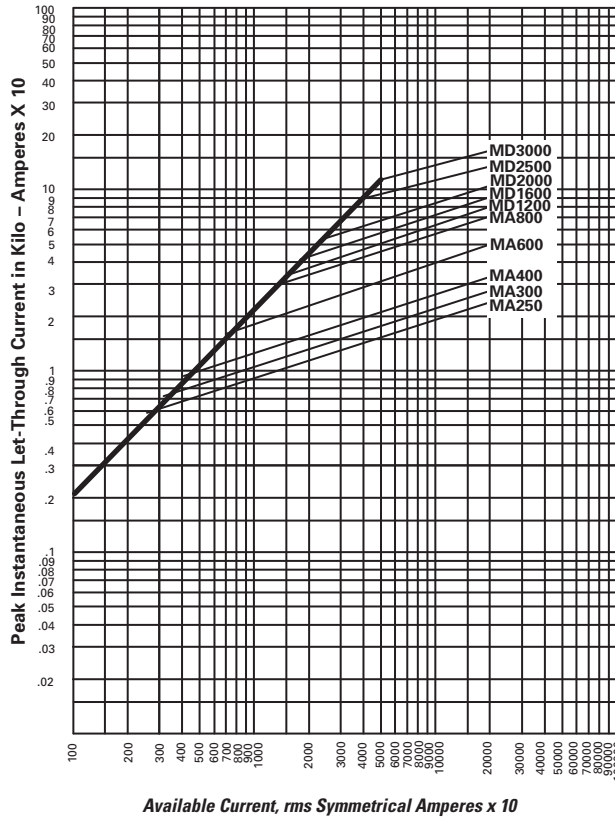
Frame	Catalog Number	Available Sensor/Rating Plug (Amperes)
800	MDSL08	200, 250, 300, 400, 600, 800
1600	MDSL16	200, 250, 300, 400, 600, 800, 1000, 1200, 1600
2000	MDSC20	1600, 2000

#### Notes

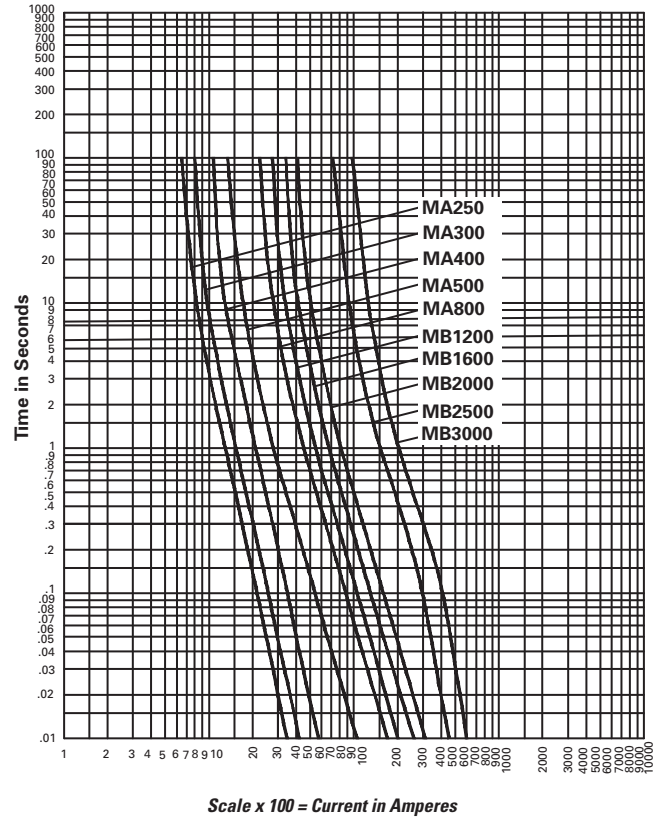
- ① Select the current limiter based on the Magnum breaker frame and current sensor and rating plug as shown.
- ② Refer to MDSL current limiter curves for let-through and time characteristics.
- ③ The recommended ratings shown as shaded provide for reduced current let-through and breaker coordination within the trip unit settings. Selection of current limiters below the recommended ratings shown provides lower current let-through, however, trip unit settings must be considered to avoid nuisance operation.

**Trip Curve Charts**

**Type Magnum DSL Limiters, Peak Let-Through Current Characteristics**



**Type Magnum DSL Limiters Average Melting Time-Current Characteristics**



**Note**  
For Time/Current Curves, see [www.eaton.com/electrical](http://www.eaton.com/electrical)



Magnum SB Low Voltage Insulated Case Circuit Breaker



## Contents

<i>Description</i>	<i>Page</i>
Low Voltage Power Circuit Breakers . . . . .	<b>V4-T26-2</b>
Magnum DS Low Voltage Power Circuit Breakers . . . . .	<b>V4-T26-6</b>
Magnum MDSL Current Limiting Power Circuit Breaker . . . . .	<b>V4-T26-11</b>
Magnum SB Low Voltage Insulated Case Circuit Breakers . . . . .	
Technical Data and Specifications . . . . .	<b>V4-T26-15</b>
Magnum IEC Rated Air Circuit Breakers . . . . .	<b>V4-T26-18</b>
Series NRX Low Voltage Power Circuit Breakers . . . . .	<b>V4-T26-27</b>
Medium Voltage Circuit Breakers . . . . .	<b>V4-T26-34</b>

## Magnum SB Low Voltage Insulated Case Circuit Breakers

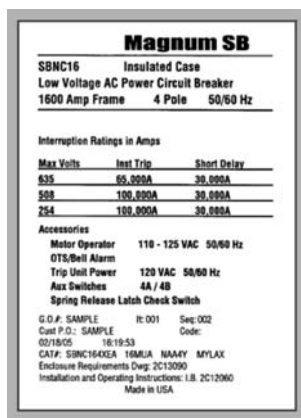
### Product Description

Magnum SB is a Low Voltage Insulated Case Circuit breaker family designed for the performance and economic requirements of UL 891 switchboards.

- Magnum SB Insulated Case Circuit Breakers have interrupting ratings up to 100 kA at 635 Vac with continuous current ratings up to 5000A
- Magnum SB Insulated Case Circuit Breakers have lighter-duty short-time withstand ratings and fixed internal instantaneous trips on most ratings, which is characteristic of UL 489 molded case breakers commonly used in UL 891 switchboards. This provides for greater economy and excellent coordination and selectivity for most commercial applications
- Fixed internal instantaneous trips will be phased in on all SB Insulated Case Circuit Breakers rated 3200A and below to provide an extra safety factor by reducing the energy let-through to

downstream circuits at the maximum instantaneous trip point and to facilitate feeder circuit breaker protection in UL 891 switchboards with 3-cycle bus bracing

- Magnum SBSE Current Limiting Power Circuit Breakers have 150 kA interrupting ratings at 480 Vac with continuous current ratings up to 5000A. The short-time withstand rating is 30 kA for standard frame and 50 kA for double frame breakers



Typical Magnum SB Low Voltage Insulated Case Circuit Breaker Nameplate

### Standards and Certifications

#### UL and ANSI Test Certifications

Magnum SB meets or exceeds the applicable ANSI, NEMA, UL and CSA standards, including:

- ANSI C37.13 (Low Voltage AC Power Circuit Breakers Used in Enclosures)
- ANSI C37.16 (Preferred Ratings, Related Requirements, and Application Recommendations for Low Voltage Power Circuit Breakers and AC Power Circuit Breakers)
- ANSI C37.17 (Trip Devices for AC and General Purpose DC Low Voltage Power Circuit Breakers)
- ANSI C37.50 (Test Procedures for Low Voltage AC Power Circuit Breakers Used in Enclosures)
- UL 1066 (Standard for Low Voltage AC and DC Power Circuit Breakers Used in Enclosures)
- NEMA SG3 (This standard adopts ANSI C37.16 in its entirety)

#### Comprehensive Enclosure Solutions

Magnum DS has proven performance in Eaton manufactured switchgear and switchboards with the following test certifications:

- UL 1558 (Certified Magnum DS Low Voltage Metal-Enclosed switchgear)
- UL 891 (Certified Pow-R-Line C Low Voltage Switchboards)
- UL, CSA 22.2.31 Low Voltage Assemblies

#### Approvals and Marks

UL listed: Magnum DS Breaker UL File E52096 and Cassette UL File E204565



#### Product Selection

Contact Eaton for pricing.

## Technical Data and Specifications

## Magnum SB Switchboard Class Insulated Case Low Voltage Air Circuit Breakers

Frame Amperes	Breaker Type Catalog Position 1–6	Frame Type	rms Symmetrical Current Ratings kA 50/60 Hz <sup>①</sup>				Short-Time Withstand Rating	Fixed Internal Instantaneous Trip	Available Current Sensor and Rating Plugs for Digitrip RMS Trip Unit (Establishes Breaker I <sub>n</sub> Rating)
			Interrupting at 254 Vac	Interrupting at 508 Vac	Interrupting at 635 Vac				
800	SBN-508	Narrow	50	50	35	20	②	200, 250, 300, 400, 600, 800	
	SBN-608	Narrow	65	65	42	20	②		
	SBN-C08	Narrow	100	100	65	20	18 x I <sub>n</sub>		
	SBS-608	Standard	65	65	65	20	②		
	SBS-C08	Standard	100	100	85	20	②		
	SBS-E08 <sup>④</sup>	Standard	200	150	③	30	30		
1200	SBN-512	Narrow	50	50	35	25	②	200, 250, 300, 400, 600, 800, 1000, 1200	
	SBN-612	Narrow	65	65	42	25	②		
	SBN-C12	Narrow	100	100	65	25	18 x I <sub>n</sub>		
	SBS-612	Standard	65	65	65	25	②		
	SBS-C12	Standard	100	100	85	25	②		
	SBS-E12 <sup>④</sup>	Standard	200	150	③	30	30		
1600	SBN-516	Narrow	50	50	35	30	②	200, 250, 300, 400, 600, 800, 1000, 1200, 1600	
	SBN-616	Narrow	65	65	42	30	②		
	SBN-C16	Narrow	100	100	65	30	18 x I <sub>n</sub>		
	SBS-616	Standard	65	65	65	30	②		
	SBS-C16	Standard	100	100	85	30	②		
	SBS-E16 <sup>④</sup>	Standard	200	150	③	30	30		
2000	SBN-620	Narrow	65	65	65	35	②	200, 250, 300, 400, 600, 800, 1000, 1200, 1600, 2000	
	SBN-C20	Narrow	100	100	65	35	18 x I <sub>n</sub>		
	SBS-620	Standard	65	65	65	35	②		
	SBS-C20	Standard	100	100	85	35	②		
	SBS-E20 <sup>④</sup>	Standard	200	150	③	30	30		
2500	SBS-625	Standard	65	65	65	45	②	200, 250, 300, 400, 600, 800, 1000, 1200, 1600, 2000, 2500	
	SBS-C25	Standard	100	100	85	45	②		
	SBS-E25 <sup>④</sup>	Double	200	150	③	50	50		
3000	SBS-630	Standard	65	65	65	50	②	200, 250, 300, 400, 600, 800, 1000, 1200, 1600, 2000, 2500, 3000	
	SBS-C30	Standard	100	100	85	50	②		
	SBS-E30 <sup>④</sup>	Double	200	150	③	50	50		
4000	SBS-840	Double	85	85	85	85	—	2000, 2500, 3000, 4000	
	SBS-C40	Double	100	100	100	100	—		
	SBS-E40 <sup>④</sup>	Double	200	150	③	50	50		
5000	SBS-850	Double	85	85	85	85	—	2500, 3000, 4000, 5000	
	SBS-C50	Double	100	100	100	100	—		
	SBS-E50 <sup>④⑤</sup>	Double	200	150	③	50	50		
6000	SBS-C60 <sup>⑤</sup>	Double	100	100	100	100	—	3000, 4000, 5000, 6000	

## Notes

- ① Interrupting ratings shown based on breaker equipped with integral Digitrip RMS Trip Unit. Interruption ratings for non-automatic breakers are equal to the published short-time withstand rating. These interruption ratings are based on the standard duty cycle consisting of an open operation, a 15-second interval and a close-open operation, in succession, with delayed tripping in case of short-delay devices. The standard duty cycle for short-time ratings consists of maintaining the rated current for two periods of 1/2 seconds each, with a 15-second interval of zero current between the two periods.
- ② Fixed internal instantaneous trip set at approximately 18 x I<sub>n</sub> symmetrical will be phased into the product.
- ③ Product to be tested. Contact Eaton for product rating.
- ④ Magnum SBSE Current Limiting Power Circuit Breaker with fast opening contacts.
- ⑤ Breaker applied in a tested fan-cooled enclosure.

Magnum SB is UL 1066 listed.

## Digitrip Trip Units for Magnum SB and Magnum DS ANSI/UL Rated Power Circuit Breakers



Trip Unit Type		Digitrip 520	Digitrip 520M	Digitrip 520MC	Digitrip 1150+ <sup>①</sup>
Ampere range		200–6000A	200–6000A	200–6000A	200–6000A
Interrupting rating at 480V		42–200 kA	42–200 kA	42–200 kA	42–200 kA
rms sensing		Yes	Yes	Yes	Yes
<b>Protection and Coordination</b>					
Protection	Ordering options	LI, LSI, LSIG	LSI, LSIG, LSIA	LSI, LSIG, LSIA	LSI, LSIG, LSIA
	Fixed rating plug ( $I_n$ )	Yes	Yes	Yes	Yes
	Overtemperature trip	Yes	Yes	Yes	Yes
Long delay protection (L)	Long delay pickup	$0.4-1.0 \times (I_n)$	$0.4-1.0 \times (I_n)$	$0.4-1.0 \times (I_n)$	$0.4-1.0 \times (I_n)$
	Long delay time $I^2t$ at $8 \times I_r$	2–24 sec	2–24 sec	2–24 sec	2–24 sec
	Long delay time $I^4t$	No	No	No	1–5 sec
	IEEE curves	No	No	No	Yes
	Long delay thermal memory	Yes	Yes	Yes	Yes
	High load alarm	No	No	No	$0.5-1.0 \times (I_r)$
Short delay protection (S)	Short delay pickup	$200-1000\% \times (I_r) \& M1$	$200-1000\% \times (I_r) \& M1$	$200-1000\% \times (I_r) \& M1$	$200-1000\% \times (I_r) \& M1$
	Short delay time $I^2t$ at $8 \times I_r$	100–500 ms	100–500 ms	100–500 ms	100–500 ms
	Short delay time flat	100–500 ms	100–500 ms	100–500 ms	100–500 ms
	Short delay time ZSI	Yes	Yes	Yes	Yes
Instantaneous protection (I)	Instantaneous pickup	$200-1000\% \times (I_n) \& M1$	$200-1000\% \times (I_n) \& M1$	$200-1000\% \times (I_n) \& M1$	$200-1000\% \times (I_n) \& M1$
	Making current release	Yes	Yes	Yes	Yes
	Off position	LSI & LSIG	Yes	Yes	Yes
Ground fault protection (G) <sup>②</sup>	Ground fault alarm	No	Yes	Yes	Yes
	Ground fault pickup	$25-100\% \times (I_n)$	$25-100\% \times (I_n)$	$25-100\% \times (I_n)$	$24-100\% \times (I_n)$
	Ground fault delay $I^2t$ at $0.625 \times I_n$	100–500 ms	100–500 ms	100–500 ms	100–500 ms
Disable ground fault protection		No	No	No	No
Neutral protection (N)		Model LSI	Model LSI	Model LSI	Model LSI
<b>System Diagnostics</b>					
Cause of trip LEDs		Yes	Yes	Yes	Yes
Magnitude of trip information		No	Yes	Yes	Yes
Remote signal contacts		No	Yes	Yes	Yes
Programmable contacts		No	No	No	Yes
Electronic operations counter		No	No	No	Yes

**Notes**

<sup>①</sup> Over and undervoltage alarm or trip, over and underfrequency alarm or trip, voltage unbalance alarm or trip, reverse power trip and phase rotation alarm are included.

<sup>②</sup> 1200A maximum ground fault setting per UL/NEC.

$I_n$  = Rating plug and sensor rating.

$I_r$  = Long delay pickup setting.

Digitrip Trip Units for Magnum SB ANSI/UL Rated Power Circuit Breakers, continued



Trip Unit Type	Digitrip 520	Digitrip 520M	Digitrip 520MC	Digitrip 1150+ <sup>①</sup>
<b>System Monitoring</b>				
Digital display	No	4-Character LCD	4-Character LCD	24-Character LED
Current (%) full scale sensor	No	Yes +/- 2%	Yes +/- 2%	Yes +/- 1%
Voltage (%) L to L	No	No	No	Yes +/- 1%
Power and energy (%)	No	No	No	Yes +/- 2%
Apparent power kVA and demand	No	No	No	Yes
Reactive power kVAR	No	No	No	Yes
Power factor	No	No	No	Yes
Crest factor	No	No	No	Yes
<b>System Communications</b>				
Type	—	—	INCOM/PowerNet/Modbus <sup>②</sup> / PROFIBUS <sup>②</sup>	INCOM/PowerNet/TripLink/ Modbus <sup>②</sup> /PROFIBUS <sup>②</sup>
Power supply in breaker	N/A	Optional	Standard	Standard
<b>Additional Features</b>				
Trip log (three events)	No	No	No	Yes
Electronic operations counter	No	No	No	Yes
Testing method <sup>③</sup>	Test set	Test set	Test set	Integral and test set
Waveform capture	No	No	No	Yes
ARMS (Arcflash Reduction Maintenance System Mode)	No	No	Yes	Yes <sup>④</sup>
Breaker health monitor	No	No	No	Yes
Programmable relay functions	No	No	No	Yes <sup>①</sup>

**Notes**

- ① Over and undervoltage alarm or trip, over and underfrequency alarm or trip, voltage unbalance alarm or trip, reverse power trip and phase rotation alarm are included.
  - ② Requires externally mounted MMINT or PMINT module.
  - ③ Test set for secondary injection.
  - ④ Contact Eaton for availability.
- $I_n$  = Rating plug and sensor rating.  
 $I_r$  = Long delay pickup setting.

Magnum Double Narrow Frame Drawout Air Circuit Breaker With Cassette



## Contents

<i>Description</i>	<i>Page</i>
Low Voltage Power Circuit Breakers . . . . .	<b>V4-T26-2</b>
Magnum DS Low Voltage Power Circuit Breakers . . . . .	<b>V4-T26-6</b>
Magnum MDSL Current Limiting Power Circuit Breaker . . . . .	<b>V4-T26-11</b>
Magnum SB Low Voltage Insulated Case Circuit Breakers . . . . .	<b>V4-T26-14</b>
Magnum IEC Rated Air Circuit Breakers	
Catalog Number Selection . . . . .	<b>V4-T26-19</b>
Technical Data and Specifications . . . . .	<b>V4-T26-21</b>
Magnum Options and Accessories . . . . .	<b>V4-T26-24</b>
Wiring Diagrams . . . . .	<b>V4-T26-26</b>
Series NRX Low Voltage Power Circuit Breakers . . .	<b>V4-T26-27</b>
Medium Voltage Circuit Breakers . . . . .	<b>V4-T26-34</b>

## Magnum IEC Rated Air Circuit Breakers

### Product Description

Magnum Air Circuit Breakers are designed to enable global power distribution solutions in IEC switchboards and other custom enclosures.

- Magnum IEC Air Circuit Breakers have interrupting ratings up to 100 kA at 690 Vac with continuous current ratings up to 6300A
- Magnum IEC Air Circuit Breaker continuous current frames are 100% rated. No thermal de-rating is required when applying the breaker in the low voltage systems enclosure at ambient temperatures of 104°F (40°C)
- Magnum IEC Breakers carry the KEMA Keur Mark, which requires periodic follow-up testing, witnessed by KEMA, to demonstrate our product performs to its published nameplate ratings. This differentiates Magnum Air Circuit Breakers from the competition, where in general, self-certification testing is performed on products when initially introduced with no binding commitments to perform subsequent follow-up third-party testing.

### Standards and Certifications

#### IEC Test Certifications

Magnum Air Circuit Breakers meet or exceed the applicable IEC standards, including:

- EN/IEC 60947-2
- KEMA third-party witness and follow-up testing

#### Comprehensive Enclosure Solutions

Magnum Air Circuit Breakers have proven performance in IEC switchboards and custom enclosures manufactured by Eaton and Low Voltage Systems Builders (OEMs) to the following standards:

- EN/IEC 60947-1
- EN/IEC 60439-1
- Eaton manufactured IEC Low Voltage Switchboard solutions include:
  - Eaton MEM M-Form (UK) Low Voltage Switchboards
  - Eaton Holec® Capitole 40 and Capitole 20 (Holland) Low Voltage Switchboards

- Eaton Tabula Low Voltage Switchboard Systems (global) for Low Voltage Systems Builders
- Eaton Elatis (Germany) Low Voltage Switchboards
- Eaton Xenergy and Modan switchboard systems (global) for low voltage systems builders
- American Bureau of Shipping (ABS)
- Det Norske Veritas (DNV)
- Lloyds of London
- South African Bureau of Standards (SABS)
- For a complete and comprehensive listing of all low voltage power breakers, please visit [www.eaton.com](http://www.eaton.com)

### Approvals and Marks

Magnum Air Circuit Breakers carry the following approvals and approval marks:

- CE
- KEMA Keur mark
- ABS (American Bureau of Shipping) Type Listed Certificate Number 04-HS422844B-PDA-DUB
- CCC (Certificate for China Compulsory Product Certification) to GB14048.2-2001, Certificate Numbers:
  - 2005010307139381
  - 2003010307094561
  - 2003010307094558



**Note:** The KEMA Keur Mark on the Magnum ACB Label Confirms Third-Party Witness and Follow-up Testing



Catalog Number Selection

Magnum IEC Breaker Product Family ①

MW N 5 12 4 V E A - 03 MT 4 F C L R Y C T M W X

**Breaker Frame**  
**I** = Standard or double  
**N** = Narrow  
**K** = Special  
 1100 Vac ACB

**Interrupting Icu**  
**4** = 40 kV  
**5** = 50 kV  
**6** = 65 kV  
**8** = 85 kV  
**C** = 100 kV  
**Z** = 25 kV  
 (1100 Vac MWK)

**Continuous Amperes and Phasing (Facing Front of Breaker)**  
**08** = 800 ABC  
**10** = 1000 ABC  
**12** = 1250 ABC  
**16** = 1600 ABC  
**20** = 2000 ABC  
**25** = 2500 ABC  
**32** = 3200 ABC  
**41** = 4000 ABC (standard drawout only)  
**4N** = 4000 AABBC  
**5N** = 5000 AABBC  
**6N** = 6300 AABBC  
**40** = 4000 ABCABC  
**50** = 5000 ABCABC  
**60** = 6300 ABCABC

**Poles and Neutral (Facing Front of Breaker)**  
**3** = Three  
**4** = Four (neutral left)  
**R** = Four (reserved for neutral right)

**Mounting Configuration and Load Terminals**  
**H** = Fixed horizontal  
**V** = Fixed vertical  
**L** = Drawout horizontal

**Nameplate Language**  
**E** = English  
**A** = Spanish

**Sensor and Rating Plug Rating**

<b>NN</b> = None	<b>13</b> = 1250
<b>02</b> = 200	<b>16</b> = 1600
<b>05</b> = 250	<b>20</b> = 2000
<b>03</b> = 300	<b>25</b> = 2500
<b>04</b> = 400	<b>30</b> = 3000
<b>06</b> = 600	<b>32</b> = 3200
<b>07</b> = 630	<b>40</b> = 4000
<b>08</b> = 800	<b>50</b> = 5000
<b>10</b> = 1000	<b>63</b> = 6300
<b>12</b> = 1200	

**Trip Unit and Protection, (and External Control Voltage When Required)**

**NN** = Non-automatic (no trip unit)  
**22** = 520 LI  
**52** = 520 LSI  
**5W** = 520i LSIG  
**M2** = 520M LSI  
**MT** = 520M LSI (24–48 Vdc)  
**MU** = 520M LSI (120 Vac)  
**MV** = 520M LSI (240 Vac)  
**MW** = 520Mi LSI  
**MJ** = 520Mi LSI (24–48 Vdc)  
**MK** = 520Mi LSI (120 Vac)  
**ML** = 520Mi LSI (240 Vac)  
**ME** = 520M LSI (24–48 Vdc)  
**MC** = 520M LSI (120 Vac)  
**MF** = 520M LSI (240 Vac)  
**CU** = 520MC LSI (24–48 Vdc)  
**CT** = 520MC LSI (120 Vac)  
**CV** = 520MC LSI (240 Vac)  
**CE** = 520MC LSI (24–48 Vdc)  
**CC** = 520MC LSI (120 Vac)  
**CF** = 520MC LSI (240 Vac)  
**CJ** = 520MCi LSI (24–48 Vdc)  
**CK** = 520MCi LSI (120 Vac)  
**CI** = 520MCi LSI (240 Vac)  
**C1** = 520MC ARMS LSI (24–48 Vdc)  
**C2** = 520MC ARMS LSI (120 Vac)  
**C3** = 520MC ARMS LSI (240 Vac)  
**C4** = 520MC ARMS LSI (24–48 Vdc)  
**C5** = 520MC ARMS LSI (120 Vac)  
**C6** = 520MC ARMS LSI (240 Vac)  
**C7** = 520MC ARMS LSI (24–48 Vdc)  
**C8** = 520MC ARMS LSI (120 Vac)  
**C9** = 520MC ARMS LSI (240 Vac)  
**1W** = 1150i LSI (24–48 Vdc)  
**1N** = 1150i LSI (120 Vac)  
**1P** = 1150i LSI (240 Vac)  
**1R** = 1150i LSI/A (24–48 Vdc)  
**1S** = 1150i LSI/A (120 Vac)  
**1T** = 1150i LSI/A (240 Vac)

**Auxiliary Switch**  
**N** = None  
**2** = 2A/2B  
**4** = 2A/2B  
**6** = 2A/2B

**Shunt Trip Attachment (STA)**  
**N** = None  
**A** = 110–127 Vac/Vdc  
**R** = 208–240 Vac/Vdc  
**C** = 24 Vdc  
**H** = 48 Vdc  
**B** = 110–127 Vac/Vdc (100% duty)  
**S** = 220–250 Vac/Vdc (100% duty)  
**D** = 24 Vdc (100% duty)  
**K** = 48 Vdc (100% duty)  
**J** = 60 Vdc (100% duty)  
**G** = 60 Vdc

**Motor Operator**  
**M** = Manual operated  
**N** = 110–125 Vac (5-sec)  
**W** = 110–125 Vdc (5-sec)  
**T** = 220–250 Vdc (5-sec)  
**P** = 220–240 Vac (5-sec)  
**L** = 24 Vdc (5-sec)  
**K** = 48 Vdc (5-sec)  
**S** = 60 Vdc (5-sec)

**Spring Release Device (SRD)**  
**N** = None  
**A** = 110–127 Vac/Vdc  
**R** = 208–240 Vac/Vdc  
**C** = 24 Vdc  
**H** = 48 Vdc  
**S** = 60 Vdc

**Undervoltage Release (UVR) or 2nd Shunt Trip (ST)**

**N** = None  
**A** = UVR (110–127 Vac)  
**R** = UVR (208–240 Vac)  
**C** = UVR (24 Vdc)  
**H** = UVR (48 Vdc)  
**D** = UVR (60 Vdc)  
**E** = UVR (110–125 Vdc)  
**F** = UVR (220–250 Vdc)  
**G** = UVR (32 Vdc)  
**X** = UVR (380–415 Vac)  
**J** = UVR (480 Vac)  
**K** = UVR (600 Vac)  
**1** = 2nd ST (110–127 Vac/Vdc)  
**2** = 2nd ST (208–250 Vac/Vdc)  
**3** = 2nd ST (24 Vdc)  
**4** = 2nd ST (48 Vdc)  
**6** = 2nd ST (60 Vdc)  
**B** = 2nd ST (110–127 Vac/Vdc 100% duty)  
**O** = 2nd ST (220–250 Vac/Vdc 100% duty)  
**I** = 2nd ST (24 Vdc 100% duty)  
**Q** = 2nd ST (48 Vdc 100% duty)  
**9** = 2nd ST (60 Vdc 100% duty)

**Future Use**  
**X** = All ACBs

**ACB Shipping Instructions**  
**A** = Fixed ACB with door kit  
**F** = Fixed ACB without door kit  
**A** = D/O ACB only without door kit  
**C** = D/O ACB in cassette (un-wired)  
**P** = D/O ACB in cassette (pre-wired)  
**S** = D/O ACB in cassette (shutters)  
**W** = D/O ACB in cassette (pre-wired and shutters)  
 Double frame D/O ACBs ship without cassette

**Latch Checking Switch/Trip Unit Metering Voltage Connection for Digitrip 1150 Trip Unit**

Latch Check Switch	1150 Voltage Connection
<b>N</b> = None	Upper terminals
<b>M</b> = None	Lower terminals
<b>L</b> = LCS wired to SRD	Upper terminals
<b>Y</b> = LCS wired to SRD	Lower terminals
<b>C</b> = LCS wired external	Upper terminals
<b>D</b> = LCS wired external	Lower terminals

**Operations Counter and/or Keylock Provisions**

	Counter	Keylock Provisions
<b>N</b> =	No counter	No locks
<b>K</b> =	No counter	Kirk lock
<b>C</b> =	No counter	Castell lock
<b>R</b> =	No counter	Ronis lock
<b>S</b> =	No counter	CES lock
<b>A</b> =	Counter	No lock
<b>Y</b> =	Counter	Kirk lock
<b>L</b> =	Counter	Castell lock
<b>H</b> =	Counter	Ronis lock indicator
<b>E</b> =	Counter	CES lock

**Padlock Provisions for Blocking Close and/or Open ACB Manual Pushbuttons**

**N** = None  
**M** = Metal (block close and open)  
**P** = Plastic (block close and open)  
**C** = Metal (block close only)  
**H** = Plastic (block close only)

**Bell Alarms Switch (OTS) with 2a/2b Contacts and/or Mechanical Trip Indicator**

	OTS 2a/2b	Trip Indicator
<b>E</b> =	No OTS	No indicator
<b>N</b> =	No OTS	With indicator
<b>Y</b> =	With OTS	With indicator
<b>M</b> =	No OTS	With interlocked indicator
<b>L</b> =	With OTS	With interlocked indicator

Note

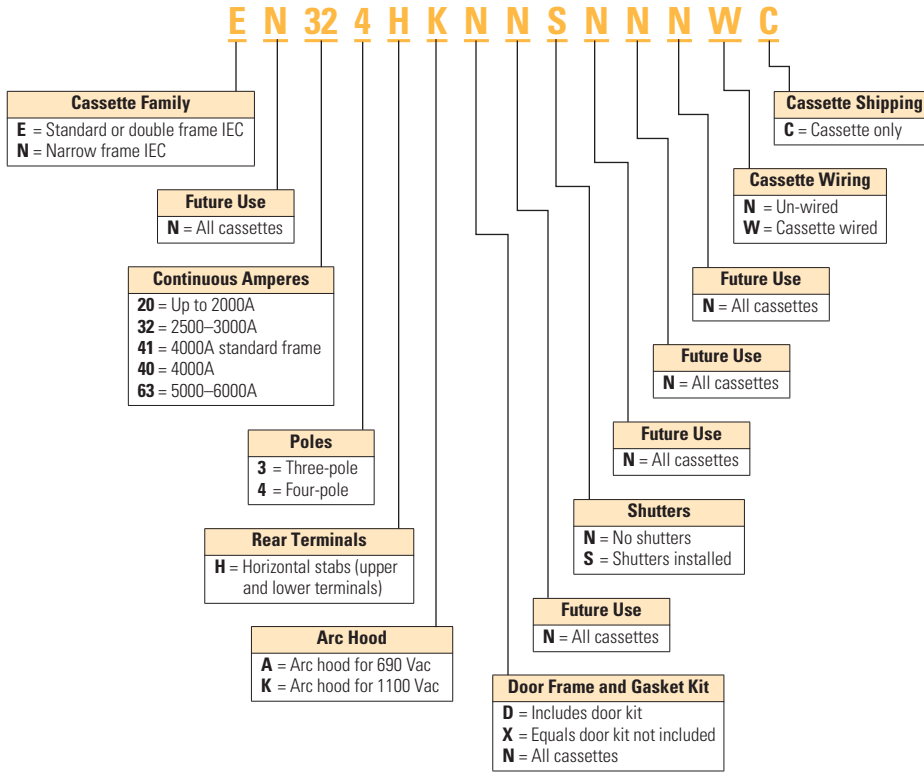
① Exclusionary rules apply. Refer to price list. Confirm all final part numbers with Eaton. Format structure subject to modifications and additions without notice.

# 26.1

## Power Breakers, Contactors and Fuses

### Power Circuit Breakers

#### Cassette Magnum IEC Breaker Product Family ①



**Note**

① Exclusionary rules apply. Refer to price list. Confirm all final part numbers with Eaton. Format structure subject to modifications and additions without notice.

## Technical Data and Specifications

## Magnum IEC 60947-2 Rated Air Circuit Breakers

Frame Amperes	Breaker Type Catalog Position 1-6	Frame Type	rms Symmetrical Current Ratings kA <sup>①</sup>			Withstand Rating I <sub>cu</sub> 1-Sec / 3-Sec	Fixed Internal Instantaneous Trip	Available Current Sensor & Rating Plugs for Digitrip RMS Trip Unit (Establishes Breaker I <sub>n</sub> Rating)
			Interrupting at 240 Vac I <sub>cu</sub> = I <sub>cs</sub>	Interrupting at 440 Vac I <sub>cu</sub> = I <sub>cs</sub>	Interrupting at 690 Vac I <sub>cu</sub> = I <sub>cs</sub>			
800	MWN-408	Narrow	40	40	40	40/—	—	200, 250, 300, 400, 630, 800
	MWN-508	Narrow	50	50	50	50/—	—	
	MWN-608	Narrow	65	65	65	65/40	—	
	MWI-608	Standard	65	65	65	65/—	—	
	MWI-808	Standard	85	85	85	85/65	—	
	MWI-C08	Standard	100	100	85	85/65	85	
1000	MWN-410	Narrow	40	40	40	40/—	—	200, 250, 300, 400, 630, 800, 1000
	MWN-510	Narrow	50	50	50	50/—	—	
	MWN-610	Narrow	65	65	65	65/40	—	
	MWI-610	Standard	65	65	65	65/—	—	
	MWI-810	Standard	85	85	85	85/65	—	
	MWI-C10	Standard	100	100	85	85/65	85	
1250	MWN-412	Narrow	40	40	40	40/—	—	200, 250, 300, 400, 630, 800, 1000, 1250
	MWN-512	Narrow	50	50	50	50/—	—	
	MWN-612	Narrow	65	65	65	65/40	—	
	MWI-612	Standard	65	65	65	65/—	—	
	MWI-812	Standard	85	85	85	85/65	—	
	MWI-C12	Standard	100	100	85	85/65	85	
1600	MWN-516	Narrow	50	50	50	50/—	—	200, 250, 300, 400, 630, 800, 1000, 1250, 1600
	MWN-616	Narrow	65	65	65	65/40	—	
	MWI-616	Standard	65	65	65	65/—	—	
	MWI-816	Standard	85	85	85	85/65	—	
	MWI-C16	Standard	100	100	85	85/65	85	
2000	MWN-520	Narrow	50	50	50	50/30	—	200, 250, 300, 400, 630, 800, 1000, 1250, 1600, 2000
	MWN-620	Narrow	65	65	65	65/40	—	
	MWI-620	Standard	65	65	65	65/50	—	
	MWI-820	Standard	85	85	85	85/65	—	
	MWI-C20	Standard	100	100	85	85/65	85	
2500	MWI-625	Standard	65	65	65	65/—	—	200, 250, 300, 400, 630, 800, 1000, 1250, 1600, 2000, 2500
	MWI-825	Standard	85	85	85	85/65	—	
	MWI-C25	Standard	100	100	85	85/65	85	
3200	MWI-632	Standard	65	65	65	65/50	—	200, 250, 300, 400, 630, 800, 1000, 1250, 1600, 2000, 2500, 3200
	MWI-832	Standard	85	85	85	85/65	—	
	MWI-C32	Standard	100	100	85	85/65	85	
4000	MWI-641 <sup>②</sup>	Standard	65	65	65	65/50	—	2000, 2500, 3200, 4000
	MWI-841 <sup>②</sup>	Standard	85	85	85	85/65	—	
	MWI-C41 <sup>②</sup>	Standard	105	105	85	85/65	—	
	MWN-64N	Double narrow	65	65	65	65/—	—	
	MWN-84N	Double narrow	85	85	65	85/—	—	
	MWN-C4N	Double narrow	100	100	65	100/—	—	
	MWI-64N	Double	65	65	65	65/—	—	
	MWI-84N	Double	85	85	85	85/—	—	
	MWI-C4N	Double	100	100	100	100/—	—	
5000	MWI-85N	Double	85	85	85	85/—	—	2500, 3200, 4000, 5000
	MWI-C5N	Double	100	100	100	100/—	—	
6300	MWI-86N	Double	85	85	85	85/—	—	3200, 4000, 5000, 6300
	MWI-C6N	Double	100	100	100	100/—	—	

## Notes

<sup>①</sup> Interrupting ratings shown based on breaker equipped with integral Digitrip RMS Trip Unit. Interruption ratings for non-automatic breakers are equal to the published breaker I<sub>cu</sub> rating.

<sup>②</sup> Magnum IEC standard frame breakers rated for 4000A continuous current are available in drawout configuration only.

## Digitrip Trip Units for Magnum IEC Rated Air Circuit Breakers



Trip Unit Type		Digitrip 520i	Digitrip 520Mi	Digitrip 520MCi	Digitrip 1150i+ <sup>①</sup>
Ampere range		200–6300A	200–6300A	200–6300A	200–6300A
Interrupting rating at 690V		40–100 kA	40–100 kA	40–100 kA	40–100 kA
rms sensing		Yes	Yes	Yes	Yes
<b>Protection and Coordination</b>					
Protection	Ordering options	LI, LSI, LSIG	LSI, LSIG, LSIA	LSI, LSIG, LSIA	LSI, LSIG, LSIA
	Fixed rating plug ( $I_n$ )	Yes	Yes	Yes	Yes
	Overtemperature trip	Yes	Yes	Yes	Yes
Long delay protection (L)	Long delay setting	0.4–1.0 x ( $I_n$ )	0.4–1.0 x ( $I_n$ )	0.4–1.0 x ( $I_n$ )	0.4–1.0 x ( $I_n$ )
	Long delay time $I^2t$ at 6 x $I_r$	2–24 sec	2–24 sec	2–24 sec	2–24 sec
	Long delay time $I^4t$	No	No	No	1–5 sec
	IEC Type A, B, C curves	No	No	No	Yes
	Long delay thermal memory	Yes	Yes	Yes	Yes
	High load alarm	No	No	No	0.7–1.0 x $I_r$
Short delay protection (S)	Short delay pickup	200–1000% x ( $I_r$ ) & M1	200–1000% x ( $I_r$ ) & M1	200–1000% x ( $I_r$ ) & M1	150–1000% x ( $I_r$ ) & M1
	Short delay time $I^2t$ at 8 x $I_r$	100–500 ms	100–500 ms	100–500 ms	100–500 ms
	Short delay time flat	100–500 ms	100–500 ms	100–500 ms	100–500 ms
	Short delay time ZSI	Yes	Yes	Yes	Yes
Instantaneous protection (I)	Instantaneous pickup	200–1000% x ( $I_n$ ) & M1	200–1000% x ( $I_n$ ) & M1	200–1000% x ( $I_n$ ) & M1	200–1000% x ( $I_n$ ) & M1
	Making current release	Yes	Yes	Yes	Yes
	Off position	Yes	Yes	Yes	Yes
Earth fault protection (G)	Earth fault alarm	No	Yes	Yes	Yes
	Earth fault pickup	25–100% x ( $I_n$ )	25–100% x ( $I_n$ )	25–100% x ( $I_n$ )	24–100% x ( $I_n$ )
	Earth fault delay $I^2t$ at 0.625 x $I_n$	100–500 ms	100–500 ms	100–500 ms	100–500 ms
	Earth fault delay flat	100–500 ms	100–500 ms	100–500 ms	100–500 ms
	Earth fault ZSI	Yes	Yes	Yes	Yes
Earth fault memory	Yes	Yes	Yes	Yes	
Disable ground fault protection		No	No	No	Yes
Neutral protection (N)		Model LSI	Model LSI	Model LSI	Model LSI
<b>System Diagnostics</b>					
Cause of trip LEDs		Yes	Yes	Yes	Yes
Magnitude of trip information		No	No	No	Yes
Remote signal contacts		No	Yes	Yes	Yes
Programmable contacts		No	No	No	2

**Notes**

① Over and undervoltage alarm or trip, over and underfrequency alarm or trip, voltage unbalance alarm or trip, reverse power trip and phase rotation alarm are included.

$I_n$  = Rating plug rating.

$I_r$  = LDPU setting.

*i* Trip units are only used on IEC breakers with earth fault.

Digitrip Trip Units for Magnum IEC Rated Air Circuit Breakers, continued



Trip Unit Type	Digitrip 520i	Digitrip 520Mi	Digitrip 520MCi	Digitrip 1150i+ <sup>①</sup>
<b>System Monitoring</b>				
Digital display	No	4-Character LCD	4-Character LCD	24-Character LED
Current (%) full scale sensor	No	Yes +/- 2%	Yes +/- 2%	Yes +/- 1%
Voltage (%) L to L	No	No	No	Yes +/- 1%
Power and energy (%)	No	No	No	Yes +/- 2%
Apparent power kVA and demand	No	No	No	Yes
Reactive power kVAR	No	No	No	Yes
Power factor	No	No	No	Yes
Crest factor	No	No	No	Yes
Power quality—harmonics	No	No	No	Yes
% THD	No	No	No	Yes
<b>System Communications</b>				
Type	—	—	INCOM/PowerNet/Modbus <sup>②</sup> / PROFIBUS <sup>②</sup>	INCOM/PowerNet/TripLink/ Modbus <sup>②</sup> /PROFIBUS <sup>②</sup>
Power supply in breaker	N/A	Optional	Standard	Standard
<b>Additional Features</b>				
Trip log (three events)	No	No	No	Yes
Electronic operations counter	No	No	No	Yes
Testing method <sup>③</sup>	Test set	Test set	Test set	Integral and test set
Waveform capture	No	No	No	Yes
ARMs (Arcflash Reduction Maintenance System Mode)	No	No	Yes	Yes <sup>④</sup>
Breaker health monitor	No	No	No	Yes
Programmable relay functions	No	No	No	Yes <sup>①</sup>

**Notes**

<sup>①</sup> Over and undervoltage alarm or trip, over and underfrequency alarm or trip, voltage unbalance alarm or trip, reverse power trip and phase rotation alarm are included.

<sup>②</sup> Requires externally mounted MMINT or PMINT module.

<sup>③</sup> Test set for secondary injection.

<sup>④</sup> Contact Eaton for availability.

$I_n$  = Rating plug rating.

$I_r$  = LDPU setting.

*i* Trip units are only used on IEC breakers with earth fault.



### Magnum Options and Accessories

#### Breaker-Mounted Options and Accessories

Magnum breakers are available with a comprehensive array of factory-installed breaker options to enable configured-to-order solutions for specified customer requirements. Field option kits are available to provide easy service, modification and customization of the breaker at the point of use.

- Shunt Trip device (ST).** Provides for remote electrically controlled breaker opening when energized by a rated voltage input
- Spring Charge Motor (MOT).** Charges the breaker closing springs automatically, facilitating remote or local closing. The motor assembly includes its own cut-off switch that changes state at the end of the charging cycle. This contact can be wired out for external indication
- Spring Release device (SR).** Provides for remote electrically controlled breaker closing when its coils are energized by a rated voltage input
- Undervoltage Release (UVR).** Trips the breaker when an existing voltage signal is lost or falls below an established threshold
- Auxiliary Switch.** Up to 6a/6b auxiliary individual dedicated contacts are available for customer use to indicate if the breaker is in the OPEN or CLOSE position
- Mechanical Trip Indicator Flag.** The red trip indicator flag pops out to provide local visual indication when the Digitrip RMS trip unit acts to trip the breaker on an overcurrent condition. Available in two options: an interlocked version that mechanically locks out the breaker until the indicator is manually reset and a non-interlocked version for indication only.
- Bell Alarm/Overcurrent Trip Switch (OTS).** Provides 2 Form C (changeover) contacts that change state when the Digitrip RMS trip unit acts to trip the breaker on an overcurrent condition. The contacts are available for external indication or customer use and are manually reset by the Mechanical Trip Indicator
- Padlockable Pushbutton Cover.** Permits padlocking hinged cover plates to block access to the PUSH ON and PUSH OFF buttons on the breaker faceplate
- Mechanical Operations Counter.** Records mechanical operations of the breaker over its installed life
- Key Off Lock Provisions.** Enables mounting of a single cylinder Kirk®, Castell or Ronis key lock to lock the breaker in the OPEN position
- Latch Check Switch.** Provides 1 Form C (changeover contact) that changes state when the breaker is ready to close. Can be wired to the Spring Release Device for fast transfer applications or wired for external ready-to-close indication



*Shunt Trip, Spring Release and Undervoltage Release Device Installed on Accessory Deck*



*Auxiliary Switches Come in Modular 2a/2b Contact Stages Providing up to 6a/6b Dedicated Contacts*



*Arc Chutes are Easily Removable for Inspection and Access to Breaker Contacts*



*Heel-Toe Contact Design Provides Demonstrated Long Life and Includes Wear Indicator for Visual Inspection*



*Mechanical Trip Indicator With Bell Alarm (OTS) Switches Mounted*

**Magnum Breaker Control Device Application Guide—Vdc**

Breaker Control Device Nominal Voltage		24 Vdc	32 Vdc	48 Vdc	60 Vdc	125 Vdc	250 Vdc
<b>Shunt Trip (ST)—Trip Circuit</b>							
Operational voltage range	70–110%	17–26 Vdc	—	34–53 Vdc	42–66 Vdc	77–138 Vdc	154–275 Vdc
Power consumption (inrush)	Required for 35 ms <sup>ⓐ</sup>	250W	—	250W	250W	450W	450W
Opening time	Seconds	35 ms	—	35 ms	35 ms	35 ms	35 ms
<b>Spring Release (SR)—Close Circuit</b>							
Operational voltage range	70–110%	17–26 Vdc	—	34–53 Vdc	42–66 Vdc	77–138 Vdc	154–275 Vdc
Power consumption (inrush)	Required for 200 ms	250W	—	250W	250W	450W	450W
Closing time	Seconds	40 ms	—	40 ms	40 ms	40 ms	40 ms
<b>Spring Charge Motor (MOT)</b>							
Operational voltage range	85–110% voltage	20–26 Vdc	—	41–53 Vdc	51–66 Vdc	94–138 Vdc	187–225 Vdc
Amperes (running)	Running	12.0A	—	5.0A	4.0A	2.0A	1.0A
Amperes (inrush)	% of running	300%	—	500%	500%	600%	600%
Power consumption	—	300W	—	250W	250W	250W	250W
Charging time	Seconds	5 sec	—	5 sec	5 sec	5 sec	5 sec
<b>Undervoltage Release (UVR)</b>							
Operational voltage range	85–110% voltage	20–26 Vdc	27–35 Vdc	41–53 Vdc	51–66 Vdc	94–138 Vdc	187–275 Vdc
Dropout voltage range	30–60% voltage	7–14 Vdc	10–19 Vdc	14–29 Vdc	18–36 Vdc	33–75 Vdc	66–150 Vdc
Power consumption (inrush)	Required for 200 ms	250W	275W	275W	275W	450W	450W
Power consumption (continuous)	Required for 400 ms	18W	15W	18W	18W	10W	10W
Opening time	Seconds	70 ms	70 ms	70 ms	70 ms	70 ms	70 ms
<b>Auxiliary Switches</b>							
Minimum load contact rating	Inductive load	0.5A	—	0.5A	—	0.5A	0.25A

**Magnum Breaker Control Device Application Guide—Vac**

Breaker Control Device Nominal Voltage		120 Vac	240 Vac	415 Vac	480 Vac	600 Vac
<b>Shunt Trip (ST)—Trip Circuit</b>						
Operational voltage range	70–110%	77–140 Vac	146–264 Vac	—	—	—
Power consumption (inrush)	Required for 35 ms	450 VA	450 VA	—	—	—
Opening time	Seconds	35 ms	35 ms	—	—	—
<b>Spring Release (SR)—close circuit</b>						
Operational voltage range	70–110%	77–140 Vac	146–264 Vac	—	—	—
Power consumption (inrush)	Required for 200 ms	450 VA	450 VA	—	—	—
Closing time	Seconds	40 ms	40 ms	—	—	—
<b>Spring Charge Motor (MOT)</b>						
Operational voltage range	85–110% voltage	93–140 Vdc	177–264 Vdc	—	—	—
Amperes (running)	Running	2.0A	1.0A	—	—	—
Amperes (inrush)	% of running	600%	600%	—	—	—
Power consumption	—	250 VA	250 VA	—	—	—
Charging time	Seconds	5 sec	5 sec	—	—	—
<b>Undervoltage Release (UVR)</b>						
Operational voltage range	85–110% voltage	94–140 Vac	177–264 Vac	323–457 Vac	408–528 Vac	510–660 Vac
Dropout voltage range	30–60% voltage	33–76 Vac	62–144 Vac	114–249 Vac	144–288 Vac	180–360 Vac
Power consumption (inrush)	Required for 200 ms	450 VA	400 VA	480 VA	400 VA	400 VA
Power consumption (continuous)	Required for 400 ms	10 VA	10 VA	10 VA	10 VA	10 VA
Opening time	Seconds	70 ms	70 ms	70 ms	70 ms	70 ms
<b>Auxiliary Switches</b>						
Minimum load contact rating	Inductive load	10A	10A	—	—	—

**Note**

<sup>ⓐ</sup> 100% duty shunt trips require power consumption (inrush) for 200 ms.

#### Wiring Diagrams

#### Typical Magnum Breaker Control Circuit

26

**Legend:**

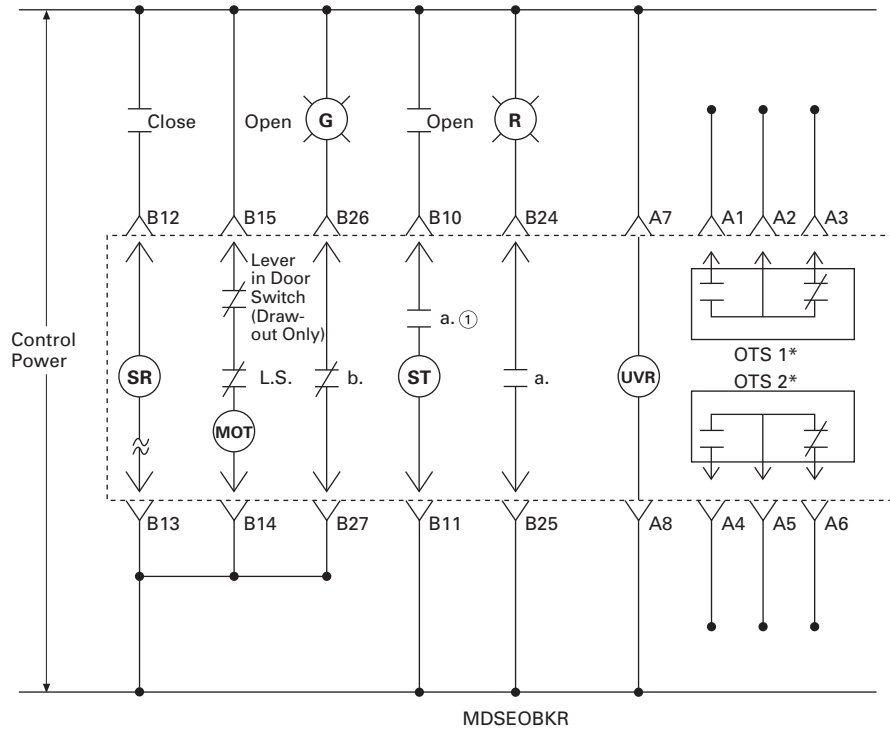
- LS Limit Switch for Closing Spring
- MOT Motor for Spring Charging
- ST Shunt Trip ①
- SR Spring Release
- UVR Undervoltage Release
- OTS Overcurrent Trip Switch

**Description of Operation:**

- 1 — Motor is energized through LS contact.
- 2 — Motor runs and charges closing spring.
- 3 — When closing spring is fully charged, LS contacts change state.
- 4 — Close contacts energize SR coil.
- 5 — When breaker closes, "b" opens.
- 6 — LS contacts change state and motor recharges closing springs.

**Notes**

- \* Contacts shown for breaker open (not fully charged), not tripped.
- - - Dotted line denotes Magnum Breaker.
- ① Not needed with 100% duty rated shunt.



Series NRX Low Voltage Power Circuit Breaker



## Series NRX Low Voltage Power Circuit Breakers

### Product Description

Series NRX is a low voltage power circuit breaker suitable for UL® 1558, UL 891, and IEC switchgear and switchboards. The compact size and weight of three-pole drawout with cassette Series NRX, see **Page V4-T26-33**, allows for a 24.00 (609.6 mm) switchgear enclosure.

### The breaker ratings are:

- 800A for UL 1066
- 800A, 1200A for UL 489
- 630–1600A IEC 60947-2 from a voltage range of 220–725 Vac

### Application Description

The Series NRX is a compact globally certified low voltage power (air) circuit breaker. It is rated for 800 amperes (UL 1066), 800 and 1200 amperes (UL 489) and 630–1600 amperes (IEC 60947-2) with an interrupting capacity of 65 kA with short time withstand at 42 kA at the 440/480 Vac level.

The Series NRX circuit breaker provides all the capabilities of a power circuit breaker in the compact size of a molded case breaker. It offers you the same protection and performance—along with increased flexibility—at half the size of a typical power circuit breaker. The dimensions and design of Series NRX allows up to eight UL 1066 or UL 489 breakers in a 24-inch (600 mm) wide structure. The one frame size, regardless of ampere rating, reduces drawing conversion, structure integration time and parts inventory for several board, gear and machinery applications.

## Contents

<b>Description</b>	<b>Page</b>
Low Voltage Power Circuit Breakers . . . . .	<b>V4-T26-2</b>
Magnum DS Low Voltage Power Circuit Breakers . . . . .	<b>V4-T26-6</b>
Magnum MDSL Current Limiting Power Circuit Breaker . . . . .	<b>V4-T26-11</b>
Magnum SB Low Voltage Insulated Case Circuit Breakers . . . . .	<b>V4-T26-14</b>
Magnum IEC Rated Air Circuit Breakers . . . . .	<b>V4-T26-18</b>
Series NRX Low Voltage Power Circuit Breakers	
Standards and Certifications . . . . .	<b>V4-T26-28</b>
Reference Information . . . . .	<b>V4-T26-28</b>
Catalog Number Selection . . . . .	<b>V4-T26-29</b>
Technical Data and Specifications . . . . .	<b>V4-T26-31</b>
Dimensions . . . . .	<b>V4-T26-33</b>
Medium Voltage Circuit Breakers . . . . .	<b>V4-T26-34</b>

## Features, Benefits and Functions

Series NRX utilizes several innovative technologies:

- Rogowski coil—does not saturate like iron core sensors, and one sensor accommodates 200–1600 ampere range. You never have to change a sensor and CTs are not required
- Tension clamp secondary terminals—10A continuous rating at 600V meets UL/CSA®/RoHS and UL-94 V0. Mounted directly to fixed breaker or drawout cassette, they reduce wiring throughout enclosure and provide clean, organized wiring schemes
- Breaker-mounted communication modules—communication modules for INCOM™, Modbus® and PROFIBUS mount directly to the cassette, reducing the space and room required in gear for communication capability
- “Direct Drive” mechanism—symmetrically loaded forces of the two-staged stored energy mechanism improves robustness, reliability, and achieves improved breaker life ratings

- Fold-up cassette—with this simple design, all items in a cassette are replaceable without removing the cassette from the cell
- “Arc chute” design
- Breaker-mounted racking or levering-in device—Racking device is mounted on the breaker, decreasing the width of the cassette, because the cassette is not burdened with the cost or parts of the lev-in
- Plug-N-Play accessories—No special tools needed. Accessory comes with plug and wires ready to install

The use of these technologies allows Series NRX to offer a life of 20,000 mechanical operations and 10,000 electrical operations with a high degree of reliability.

**Standards and Certifications**

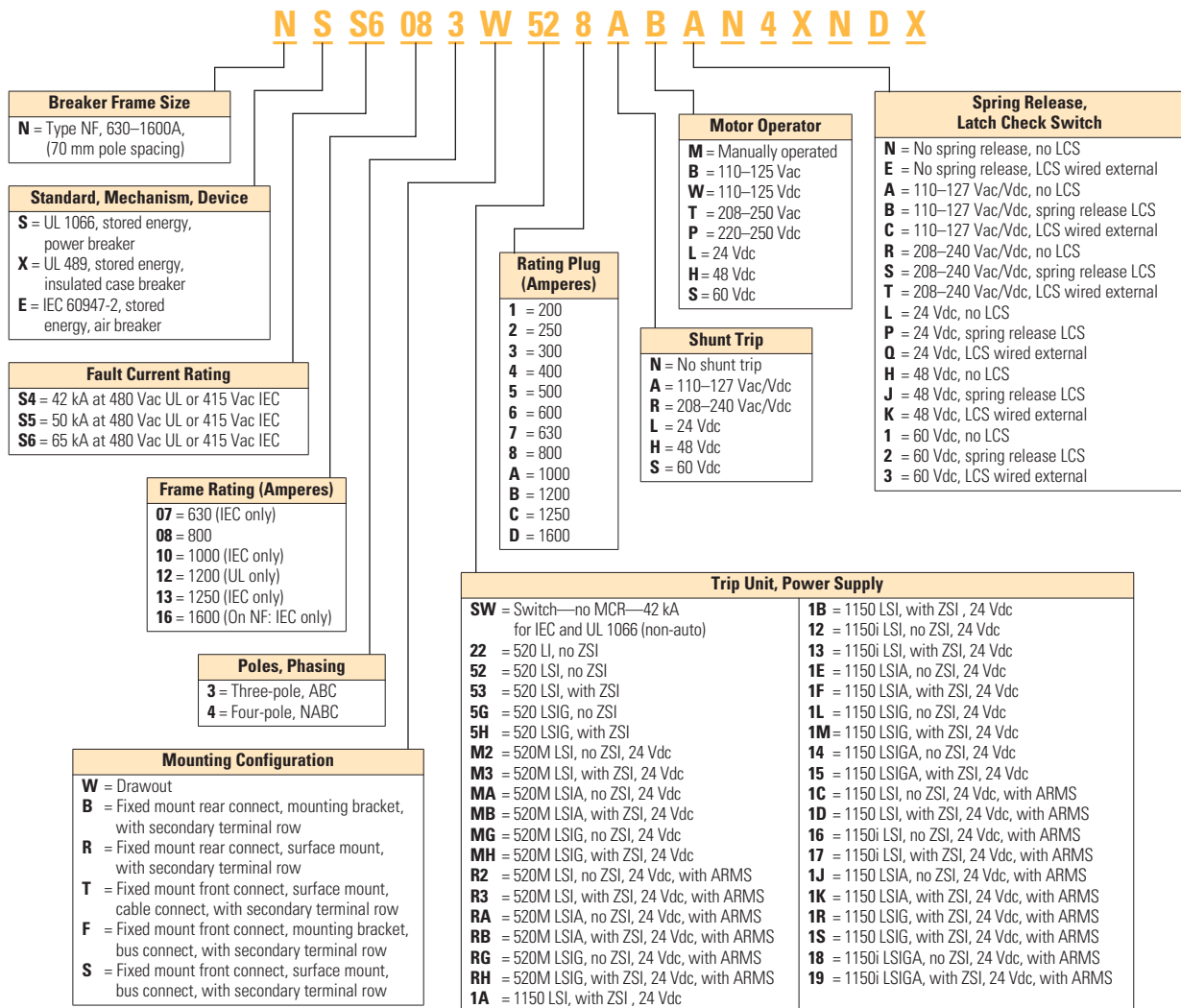
- UL 1066 (low voltage AC power circuit breakers used in enclosures)
- UL 489 (molded-case circuit breakers, molded case switches and circuit breaker enclosures)
- EN 45011
- CEI EN 60947
- BS EN 60439-1 Form 4b
- IEC 60439-1 (low voltage switchgear and controlgear assemblies)
- IEC 60947-1 (low voltage switchgear and controlgear—Part 1 general rules)
- IEC 60947-2 (low voltage switchgear and controlgear—Part 2 circuit breakers)
- IEC 60947-3 (switches, disconnectors, switch-disconnectors and fuse-combination units)
- CSA 22.2 (molded-case circuit breakers, molded case switches and circuit breaker enclosures)
- ANSI C37.51 (metal-enclosed low voltage AC power circuit breaker switchgear assemblies—conformance test procedures)
- ANSI C37.20.1 (metal-enclosed low voltage power circuit breaker switchgear)
- ANSI C37.60 (requirements for overhead, pad-mounted dry-type and submersible automatic reclosers and fault interrupters for AC systems)
- ANSI C37.50 (low voltage AC power circuit breakers used in enclosures—test procedures)
- ANSI C37.17 (for trip devices for AC and general purpose DC low voltage power circuit breakers)
- ANSI C37.16 (low voltage power circuit breakers and AC power circuit protectors—preferred ratings, related requirements, and application recommendations)
- ANSI C37.13 (IEEE® standard for low voltage AC power circuit breakers used in enclosures)
- CCC—China
- KEMA (&CB)
- UL 891 (deadfront switchboard)
- UL 1558 (metal-enclosed low voltage power circuit breaker switchgear)

**Reference Information****List of Instruction Leaflets and Manuals**

Description	Publication Number
Instruction Book for Fixed and Drawout Breaker/Cassette	MN01301001E
IL Drawout Circuit Breaker and Cassette Rejection Interlocks	IL01301006E
IL Auxiliary Switch in Right Accessory Tray	IL01301007E
IL UVR/ST/OTS in Left Accessory Tray	IL01301008E
IL Motor Operator	IL01301010E
IL Spring Release Device and Latch Check Switch (Numbers 5 and 6 are Combining into one Document)	IL01301010E
IL Door Escutcheon and Gasket Kit	IL01301012E
IL Drawout Cassette IP 20 Shutters	IL01301013E
IL Fixed Breaker Arc Hood Kit	IL01301014E
IL Fixed Breaker Front/Rear/Cable Connectors	IL01301015E
IL Drawout Cassette Front/Rear/Cable Connectors	IL01301016E
IL Racking Device Levering Device	IL01301018E
IL Mechanical Pop-Out Indicator and Interlocked Indicator	IL01301019E
IL Breaker and Cassette Phase Barriers	IL01301021E
IL Cassette Rails	IL01301025E
IL Mounting Feet	IL01301030E
IL Surface Mount	IL01301036E
IL Terminal Blocks	IL01301037E
IL Modbus Communication Adapter Module	IL01301034E
IL INCOM Communication Adapter Module	IL01301033E
IL Digitrip 520 and 520M Manual	IL70C1619H01
IL IP55 Cover	IL01301038E
PROFIBUS Communication Module	IL01301035E
IL Kirk Key Lock	IL01301039E
IL Ronis Key Lock	IL01301040E
IL Pushbutton Covers	IL01301041E

Catalog Number Selection

Series NRX Type NF-Frame Circuit Breaker (Exclusionary Rules Apply)



# 26.1

## Power Breakers, Contactors and Fuses

### Power Circuit Breakers

#### Series NRX Type NF-Frame Circuit Breaker (Exclusionary Rules Apply), continued

**N S S6 08 3 W 52 8 A B A N 4 X N D X**

26

**UVR, Second Shunt Trip**

N = None  
 A = 110–125 Vac/Vdc UVR  
 R = 220–250 Vac/Vdc UVR  
 L = 24 Vdc UVR  
 H = 48 Vdc UVR  
 S = 60 Vdc UVR  
 G = 32 Vdc UVR  
 1 = 110–127 Vac/Vdc second shunt trip  
 2 = 208–240 Vac/Vdc second shunt trip  
 4 = 24 Vdc second shunt trip  
 8 = 48 Vdc second shunt trip  
 9 = 60 Vdc second shunt trip

**Auxiliary, Switches, Label Language**

E = No auxiliary switches, no label (parent)  
 2 = 2 Form C, English  
 4 = 4 Form C, English

	Trip Indicator and Bell Alarm	OTS	Secondary Terminal Blocks
N	None	None	Per breaker options
X	Trip indicator	None	Per breaker options
Z	Trip indicator	2 Form C	Per breaker options
M	Interlock trip indicator	None	Per breaker options
Y	Interlock trip indicator	2 Form C	Per breaker options
1	None	None	Full complement
2	Trip indicator	None	Full complement
3	Trip indicator	2 Form C	Full complement
4	Interlock trip indicator	None	Full complement
5	Interlock trip indicator	2 Form C	Full complement

	Padlock Provisions	Key Lock Provisions	Operations Counter
N	No	None	No
A	No	—	Provided
B	Yes (plastic/plastic)	—	No
C	Yes (plastic/plastic)	—	Provided

**Future Use**

X = All product

**Drawout Breaker Shipping, Fixed Breaker Terminals (Door Frame Kit ships as standard unless noted otherwise)**

D = Drawout (or parent) breaker shipping alone, without door frame kit  
 C = Drawout breaker in cassette, no shutters, no terminals  
 1 = Drawout breaker in cassette, no shutters, short vertical/horizontal  
 2 = Drawout breaker in cassette, no shutters, long vertical/horizontal  
 4 = Drawout breaker in cassette, with shutters, short vertical/horizontal  
 5 = Drawout breaker in cassette, with shutters, long vertical/horizontal  
 9 = Drawout breaker in cassette, no shutters, no terminals  
 A = Fixed terminal adapters for rear connect, short vertical/horizontal  
 E = Fixed terminal adapters for rear connect, long vertical/horizontal  
 F = Fixed terminal adapters for rear connect, with mounting feet, short vertical/horizontal  
 H = Fixed terminal adapters for rear connect, with mounting feet, long vertical/horizontal

#### Series NRX Type NF-Frame Cassette

**NX 12 3 F A B N S N N N C**

**Cassette Family and Breaker Frame**

NS = UL 1066 N-Frame  
 NX = UL 489 N-Frame  
 NE = IEC N-Frame

**Continuous Ampere Range**

08 = 800 (UL 1066)  
 12 = 800–1200 (UL 489)  
 16 = 630–1600 (IEC)

**Poles and Phasing (Facing Front of Breaker)**

3 = Three-pole ABC  
 4 = Four-pole NABC

**Load Terminal Connections**

F = With flat tapped pads only  
 G = With vertical/horizontal bus adapter kit (short style)  
 H = With front-connected kit  
 N = No cassette stabs (interunit only)

**Arc Hood**

A = Arc hood installed (default)

**Door Frame Gasket and Rejection Kits**

B = Door kit included (default), with rejection kit  
 D = Door kit included, no rejection kit  
 R = Not included, with rejection kit  
 N = Not included, with rejection kit

**TOC Switches (Truck Operated Cell)**

N = Not included (default)

**Cassette Shipping**

C = Cassette only  
 B = Breaker shipped in cassette

**Future**

N = None

**Future**

N = None

**Secondary Contact Terminals Installed**

N = None  
 B = Breaker defined, when breaker ships in cassette  
 F = Full complement  
 C = Common options when cassette ships alone


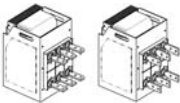


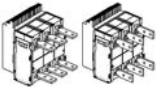
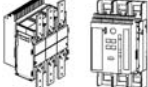


**Shutters**

N = Not included (default)  
 S = Included



Technical Data and Specifications

Mounting and Load Connection Configurations

Breaker Type	Breaker Mechanism	Standard Bus Connection Provisions	Rear-Connected Horizontal/Vertical Adapter Kit With and Without Cover (Kits Shipped Unassembled)	Front-Connected Horizontal/Vertical Adapter Kit With and Without Cover (Kits Shipped Unassembled)	Cable-Connected Cable Terminals With Cover
Drawout Breaker	Stored energy	Finger clusters	—	—	—
					
Cassette	—	Rear-connected pre-drilled bus pads			—
					
Fixed	Stored energy	Rear-connected pre-drilled bus pads			
					

UL 1066 Ratings

Description	Rating
Continuous current rating (amperes)	800
<b>Short-Circuit Rating (kA)</b>	
254 Vac	85
508 Vac	65
635 Vac	35
Short-time withstand (kA) <sup>①</sup>	42

UL 489 Ratings

Description	Rating	Rating
Continuous current rating (amperes)	800	1200
<b>Short-Circuit Rating (kA)</b>		
240 Vac	85	85
480 Vac	65	65
600 Vac	42	42
Short-time withstand (kA)	42	42

IEC 60947-2 Ratings

Description	Rating		Rating		Rating	
Continuous current rating (amperes)	630 and 800		1000 and 1250		1600	
Short-circuit rating (kA)	Icu	Ics	Icu	Ics	Icu	Ics
240/254 Vac	85	50	85	50	85	50
415/435 Vac	65	50	65	50	65	50
690/725 Vac	42	42	42	42	42	42
Short-time withstand = Icw (kA)	42	42	42	42	42	42

Note

<sup>①</sup> 35 kAIC short-time withstand at 635V level only. All other voltages 42 kAIC short-time withstand.

**Accessory Ratings****Shunt Trip**

Control Voltages	Frequency	Operational Voltage Range 70–110%	Inrush/Continuous Power Consumption (VA)	Opening Time (ms)
24	DC	17–26	500/5	25
48	DC	34–53	530/5	25
110–127	50–60 Hz	77–140	540/5	25
110–125	DC	77–138	540/5	25
208–240	50–60 Hz	146–264	500/5	25
220–250	DC	154–275	515/5	25

**UVR**

Control Voltages	Frequency	Operational Voltage Range 85–110%	Dropout Volts 35–60%	Inrush/Continuous Power Consumption (VA)	Opening Time (ms)
24	DC	20–26	8–14	500/5	50
32	DC	27–35	11–19	620/5	50
48	DC	41–53	17–29	850/5	50
110–127	50–60 Hz	94–140	44–94	890/5	50
110–125	DC	94–138	44–94	890/5	50
208–240	50–60 Hz	177–264	84–125	910/5	50
220–250	DC	187–275	88–132	910/5	50
380–415	AC	323–457	145–228	960/5	50
480	AC	408–528	168–288	800/8	50
600	AC	510–660	210–360	800/12	50

**Spring Release**

Control Voltages	Frequency	Operational Voltage Range 70–110%	Inrush Power Consumption (VA)	Closing Time (ms)
24	DC	17–26	500	25
48	DC	34–53	530	25
110–127	50–60 Hz	77–140	540	25
110–125	DC	77–138	540	25
208–240	50–60 Hz	146–264	500	25
220–250	DC	154–275	515	25

**OCT/OTS**

Control Voltages	Frequency	Contact Rating (Amperes)
250	50–60 Hz	10
125	DC	0.5
250	DC	0.25

**Auxiliary Switch**

Control Voltages	Frequency	Contact Rating (Amperes)
250	50–60 Hz	10
125	DC	0.5
250	DC	0.25

**Breaker Position/Continuity**

Breaker Position	Continuity Between Red and Black Lead Pairs	Continuity Between Blue and Black Lead Pairs
Open	NO	45 and 43
	NO	46 and 47
	NO	51 and 49
	NO	52 and 53
Closed	44 and 43	NO
	48 and 47	NO
	50 and 49	NO
	54 and 53	NO

**Motor Operator**

Control Voltages	Frequency	Operational Voltage Range 85–110%	Running Current (A)	Typical Inrush Current	Power Consumption (VA)	Maximum Charging Time (Sec)
24	DC	20–26	5	500%	150	3
48	DC	41–53	3	500%	150	3
110–127	50–60 Hz	94–140	2	300%	280	3
110–125	DC	94–138	1	500%	150	3
208–240	50–60 Hz	177–264	1	1000%	280	4
220–250	DC	187–275	1	1000%	280	4

**Control Voltages and Currents**

Control Voltages	24 Vdc	48 Vdc	110–125 Vdc	110–127 Vac	220–250 Vdc	208–240 Vac
<b>Current</b>						
Close current (inrush)	21	11	5	5	2	2
Shunt trip current (ST)—(inrush/continuous)	21 / .2	11 / .1	5 / .04	5 / .04	2 / .02	2 / .02
Charge motor current—(inrush/continuous)	TBD	TBD	5 / 1	6 / 2	10 / 1	10 / 1
<b>Operating Voltage Rating</b>						
Close	17–26	34–53	77–138	77–140	154–275	146–264
Trip	17–26	34–53	77–138	77–140	154–275	146–264
Charge	20–26	41–53	94–138	94–140	187–275	177–264

**Dimensions**

Approximate Dimensions in Inches (mm)

**Series NRX Three-Pole Drawout with Cassette**

Height	Width	Depth	Lbs (kg)
14.18 (360.2)	10.02 (254.5)	10.68 (271.3)	85.00 (38.59)

**Fixed Circuit Breaker and Drawout with Cassette**

Breaker Type	Height	Width	Depth	Lbs (kg)
<b>Fixed</b>				
Three-pole	13.18 (334.8)	8.25 (209.6)	7.15 (181.6)	33.58 (15.23)
Four-pole	13.18 (334.8)	11.00 (279.4)	7.15 (181.6)	44.40 (20.14)
<b>Drawout with Cassette</b>				
Three-pole	14.18 (360.2)	10.02 (254.5)	10.69 (271.5)	85.20 (38.65)
Four-pole	14.18 (360.2)	12.69 (322.3)	10.69 (271.5)	104.00 (47.17)

Type VCP-W/VCP-T Medium Voltage Vacuum Circuit Breaker



## Contents

<i>Description</i>	<i>Page</i>
Low Voltage Power Circuit Breakers . . . . .	<b>V4-T26-2</b>
Magnum DS Low Voltage Power Circuit Breakers . . . . .	<b>V4-T26-6</b>
Magnum MDSL Current Limiting Power Circuit Breaker . . . . .	<b>V4-T26-11</b>
Magnum SB Low Voltage Insulated Case Circuit Breakers . . . . .	<b>V4-T26-14</b>
Magnum IEC Rated Air Circuit Breakers . . . . .	<b>V4-T26-18</b>
Series NRX Low Voltage Power Circuit Breakers . . . . .	<b>V4-T26-27</b>
Medium Voltage Circuit Breakers	
Features, Benefits and Functions . . . . .	<b>V4-T26-35</b>
Standards and Certifications . . . . .	<b>V4-T26-35</b>
Product Selection . . . . .	<b>V4-T26-36</b>
Technical Data and Specifications . . . . .	<b>V4-T26-36</b>
Dimensions . . . . .	<b>V4-T26-49</b>

## Medium Voltage Circuit Breakers

### Product Description

Breakers and structures for switchgear assemblies:

#### ANSI

- VCP-W medium voltage circuit breakers
  - 5/15 kV VCP-W (K>1, K=1, narrow design, extra-capability and generator circuit breakers available)
  - 27 kV and 38 kV (extra-capability circuit breakers available)
  - Ground and test devices
  - Dummy elements
- VCP-T medium voltage circuit breakers
  - 5/15 kV VCP-T (capacitor switching and magnetic actuated circuit breakers available)
  - Ground and test devices
  - Dummy elements

#### IEC

- T-VAC medium voltage circuit breakers
  - 5/15 kV VCP-T (capacitor switching circuit breakers available)
  - Ground and test devices
  - Dummy elements
- VCP-W IEC medium voltage circuit breakers
  - 3.6/7.2/12/17.5 kV
  - 24 kV

#### OEM Structures

- Metal-clad, compartmented design
- Barebones
- Power modules
- Mini modules
- Breaker compartment kits

### Application Description

- Eaton's medium voltage circuit breakers offer the latest in vacuum technology, providing superior control and protection of medium voltage power equipment in utility, industrial, commercial, mining and marine installations. Built in a state-of-the-art ISO 9002 certified facility, they meet and exceed all ANSI and IEC requirements. Available in drawout configurations, Eaton's vacuum circuit breakers are a result of our ongoing commitment to research and development, which have resulted in significant breakthrough technologies. Each breaker is provided with its unique Quality Assurance Certificate that documents all tests and inspections performed.

**Features, Benefits and Functions*****VCP-W Standard Features***

- Eaton's maintenance-free vacuum interrupters with visual contact erosion indicator
- Non-sliding/non-rolling V-flex™ current transfer system
- Glass polyester insulation
- Cycloaliphatic epoxy insulation (optional with Type VCPW-SE breakers) for 27 kV and 38 kV breakers
- Front-accessible operating mechanism
- Electrically operated trip-free, spring stored energy mechanism
- Interlocks that prevent moving a closed circuit breaker into or out of the connected position
- Closing springs automatically discharge before moving the circuit breaker into or out of the enclosure
- Provisions for manual charging of closing springs
- Manual close and trip pushbuttons
- Operations counter
- Closing spring charged/discharged indicator
- Circuit breaker Open/Closed indicator
- Auxiliary switch with 2A/3B for DC and 1A/3B for AC spare contacts
- Spring charging motor, close coil, trip coil, latch check switch and anti-pump relay

***VCP-T Standard Features***

- Small without compromise—significantly smaller and lighter than comparable breakers
- Grounded steel barrier between mechanism and primary conductors
- Spring loaded, silver-plated primary disconnects (drawout breaker)
- Silver-plated primary connections (fixed circuit breaker)
- Manual charging of closing springs (includes shunt trip)
- Integral spring charging handle
- Auxiliary switch (5a and 5b contacts)
- Mechanical operations counter
- 24, 48, 125 and 250 Vdc, 120 and 240 Vac control
- Shunt trip
- ON and OFF pushbuttons
- Integral lifting hooks
- Through- or behind-door operation
- Identified/dedicated secondaries
- Secondary umbilical cord (drawout circuit breaker)
- Secondary disconnect block (fixed circuit breaker)
- Two-step stored energy mechanism
- O–0.3s–CO–15s–CO
- Anti-pump
- Trip free
- Latch check switch
- Visible contact erosion indicator
- Visible contact wipe indicator
- Disconnect, Test and Connect (drawout circuit breaker)
- Integral levering mechanism (drawout circuit breaker)
- Field-installable accessories

**Standards and Certifications**

- Designed, tested and certified in accordance with ANSI and IEC standards
- Applicable ANSI standards C37.04-1979 or 1999, C37.09-1979 or 1999, C37.06-2000 and C37.013
- Internal arc resistance tested to IEC 298, Appendix AA, 25 kA for 1 second
- Drawout circuit breaker fully qualified to IEC 56 by testing inside the IEC 298 switchgear cubicle
- IEEE C37.013 and amendment C37.013a-2007

**Product Selection**

Please contact your Eaton sales representative for additional product information and to review your specific application and required product configuration.

**Technical Data and Specifications****ANSI Standards****ANSI Standard Ratings—VCP-W Vacuum Circuit Breaker Types Rated on Symmetrical Current Rating Basis—Standard Circuit Breakers** <sup>①</sup>

Description	Circuit Breaker Type								
	50 VCP-WND250	50 VCP-W250	50 VCP-W350	50 VCP-W500 (63 kA)	75 VCP-W500	150 VCP-W500	150 VCP-W750	150 VCP-W1000	150 VCP-W1500 (63 kA)
<b>Identification</b>									
Nominal voltage class kV	4.16	4.16	4.16	4.16	7.2	13.8	13.8	13.8	13.8
Nominal three-phase MVA class	250	250	350	—	500	500	750	1000	—
<b>Rated Values</b>									
<b>Voltage</b>									
Maximum voltage E kV rms	4.76	4.76	4.76	4.76	8.25	15	15	15	15
Voltage range factor K <sup>②</sup>	1.24	1.24	1.19	1.00	1.25	1.30	1.30	1.30	1.00
<b>Insulation Level</b>									
Withstand test voltage									
Power frequency (1 min.) kV rms	19	19	19	19	36	36	36	36	36
Impulse kV peak	60	60	60	60	95	95	95	95	95
<b>Current</b>									
Continuous current at 60 Hz amperes	1200	1200	1200	1200	1200	1200	1200	1200	1200
		2000	2000	2000	2000	2000	2000	2000	2000
		3000	3000	3000	3000	3000	3000	3000	3000
Short-circuit current (at rated max. kV) I kA rms	29	29	41	63	33	18	28	37	63
Interrupting time cycles	5	5	5	5	5	5	5	5	5
Permissible tripping delay Y seconds	2	2	2	2	2	2	2	2	2
Maximum voltage divided by K E/K kV rms <sup>②</sup>	3.85	3.85	4.0	4.76	6.6	11.5	11.5	11.5	15.0
<b>Current Values</b>									
Maximum symmetrical interrupting capability Short-time current K x 1 kA rms <sup>②</sup>	36	36	49	63	41	23	36	48	63
Closing and latching capability kA peak	97	97	132	170	111	62	97	130	170
Closing and latching momentary capability	58	58	78	101	66	37	58	77	101
<b>Weight Lbs (kg)</b>									
1200A	345 (157)	350 (159)	460 (209)	525 (238)	375 (170)	350 (159)	350 (159)	460 (209)	525 (238)
2000A	345 (157)	410 (186)	490 (223)	530 (241)	410 (186)	410 (186)	410 (186)	490 (223)	530 (241)
3000A	345 (157)	525 (238)	525 (238)	550 (250)	525 (238)	525 (238)	525 (238)	525 (238)	550 (250)

**Notes**

<sup>①</sup> Applicable ANSI Standards C37.04-1999, C37.06-2000 (including both K >1 and K =1 ratings), and C37.09-1999.

<sup>②</sup> See *Consulting Application Guide* for further information.

**ANSI Standard Ratings—VCP-W Vacuum Circuit Breaker Types Rated on Symmetrical Current Rating Basis—  
Extra Capability Breakers <sup>①</sup>**

Description	Circuit Breaker Type								
	50 VCP-W25C	50 VCP-W40C	50 VCP-W50C	50 VCP-W63C	75 VCP-W50C	150 VCP-W25C	150 VCP-W40C	150 VCP-W50C	150 VCP-W63C
<b>Identification</b>									
Nominal voltage class kV	4.16	4.16	4.16	4.16	7.2	13.8	13.8	13.8	13.8
Nominal three-phase MVA class	—	—	—	—	—	—	—	—	—
<b>Rated Values</b>									
<b>Voltage</b>									
Maximum voltage E kV rms	5.95	5.95	5.95	5.95	10.3	17.5	17.5	17.5	15.0
Voltage range factor K <sup>②</sup>	1.00	1.00	1.00	1.00	1.00	1.00	1.00	1.00	1.00
<b>Insulation Level</b>									
Withstand test voltage									
Power frequency (1 min.) kV rms	24	24	24	24	42	42	42	42	42
Impulse kV peak	75	75	75	75	95	95	95	95	95
<b>Current</b>									
Continuous current at 60 Hz amperes	1200	1200	1200	1200	1200	1200	1200	1200	1200
	2000	2000	2000	2000	2000	2000	2000	2000	2000
	3000	3000	3000	3000	3000	3000	3000	3000	3000
Short-circuit current (at rated max. kV) I kA rms	25	40	50	63	50	25	40	50	63
Interrupting time cycles	3	3	3	3	3	3	3	3	3
Permissible tripping delay Y seconds	2 <sup>③</sup>	2 <sup>③</sup>	2 <sup>③</sup>	2 <sup>③</sup>	2 <sup>③</sup>	2 <sup>③</sup>	2 <sup>③</sup>	2 <sup>③</sup>	2 <sup>③</sup>
Maximum voltage divided by K E/K kV rms <sup>②</sup>	5.95	5.95	5.95	5.95	10.3	17.5	17.5	17.5	15.0
<b>Current Values</b>									
Maximum symmetrical interrupting capability Short-time current K x 1 kA rms <sup>②</sup>	25	40	50	63	50	25	40	50	63
Closing and latching capability kA peak	97	139	139	175	139	97	139	139	175
Closing and latching momentary capability	58	83	83	104	83	58	83	83	104
<b>Weight Lbs (kg)</b>									
1200A	350 (159)	460 (209)	525 (238)	350 (159)	460 (209)	350 (159)	350 (159)	460 (209)	525 (238)
2000A	410 (186)	490 (223)	530 (241)	410 (186)	490 (223)	410 (186)	410 (186)	490 (223)	530 (241)
3000A	525 (238)	525 (238)	550 (250)	525 (238)	525 (238)	525 (238)	525 (238)	525 (238)	550 (250)

**Notes**

<sup>①</sup> Applicable ANSI Standards C37.04-1999, C37.06-2000 (including both K >1 and K =1 ratings), and C37.09-1999.

<sup>②</sup> See *Consulting Application Guide* for further information.

<sup>③</sup> Tested for 3 seconds.



**ANSI Standard Ratings—VCP-W Vacuum Circuit Breaker Types Rated on Symmetrical Current Rating Basis—  
Generator Breakers (to ANSI C37.013) ①**

Description	Circuit Breaker Type					
	50 VCP-WG50	50 VCP-WG63	50 VCP-WG75	150 VCP-WG50	150 VCP-WG63	150 VCP-WG75
<b>Identification</b>						
Nominal voltage class kV	4.16	4.16	4.16	13.8	13.8	13.8
Nominal three-phase MVA class	—	—	—	—	—	—
<b>Rated Values</b>						
<b>Voltage</b>						
Maximum voltage E kV rms	4.76	4.76	4.76	15.0	15.0	15.0
Voltage range factor K ②	1.00	1.00	1.00	1.00	1.00	1.00
<b>Insulation Level</b>						
Withstand test voltage						
Power frequency (1 min.) kV rms	19	19	19	36	36	36
Impulse kV peak	60	60	60	95	95	95
<b>Current</b>						
Continuous current at 60 Hz amperes	1200	1200	1200	1200	1200	1200
	2000	2000	2000	2000	2000	2000
	3000	3000	3000	3000	3000	3000
	4000	4000	4000	4000	4000	4000
Short-circuit current (at rated max. kV) kA rms	50	63	75	50	63	75
Interrupting time cycles						
1200A	3	3	3	3	3	3
2000A	3	3	3	3	3	3
3000A	3	3	3	3	3	3
4000A	5	5	5	5	5	5
Permissible tripping delay Y seconds						
1200A	1 and 3	1 and 3	1 and 3	1 and 3	1 and 3	1 and 3
2000A	1 and 3	1 and 3	1 and 3	1 and 3	1 and 3	1 and 3
3000A	1 and 3	1 and 3	1 and 3	1 and 3	1 and 3	1 and 3
4000A	1	1	1	1	1	1
Maximum voltage divided by K E/K kV rms ②	4.76	4.76	4.76	15.0	15.0	15.0
<b>Current Values</b>						
Maximum symmetrical interrupting capability						
Short-time current K x 1 kA rms ②	50	63	75	50	63	75
Closing and latching capability kA peak	137	173	206	137	173	206
Closing and latching momentary capability	82	103	123	82	103	123
<b>Weight Lbs (kg)</b>						
1200A	525 (238)	525 (238)	926 (419)	525 (238)	525 (238)	926 (419)
2000A	530 (241)	530 (241)	936 (424)	530 (241)	530 (241)	936 (424)
3000A	550 (250)	550 (250)	946 (429)	550 (250)	550 (250)	946 (429)
4000A	956 (433)	956 (433)	956 (433)	956 (433)	956 (433)	956 (433)

**Notes**

① Applicable ANSI Standards C37.04-1999, C37.06-2000 (including both K >1 and K =1 ratings), C37.09-1999 and C37.013 (including C37.013a-2007).

② See *Consulting Application Guide* for further information.

## Available Type VCP-W Vacuum Circuit Breakers Rated on Symmetrical Current Basis Per ANSI Standards (Rated K=1)

Identification	Drawout Circuit Breaker Type									
	50 VCP-W25	50 VCP-W40	50 VCP-W50	50 VCP-W63	75 VCP-W40	75 VCP-W50	150 VCP-W25	150 VCP-W40	150 VCP-W50	150 VCP-W63
<b>Rated Values</b>										
Maximum voltage (V) kV rms	4.76	4.76	4.76	4.76	8.25	8.25	15	15	15	15
Power frequency Hz <sup>①</sup>	60	60	60	60	60	60	60	60	60	60
<b>Insulation Level</b>										
Power frequency withstand voltage (1 min.) kV rms	19	19	19	19	36	36	36	36	36	36
Lightning impulse withstand voltage (1.2 x 50 μs) kV peak	60	60	60	60	95	95	95	95	95	95
Continuous current A rms <sup>②</sup>	1200	1200	1200	1200	1200	1200	1200 <sup>Ⓜ</sup>	1200	1200	1200 <sup>Ⓜ</sup>
	2000	2000	2000	2000	2000	2000	2000	2000	2000	2000 <sup>Ⓜ</sup>
	3000	3000	3000	3000	3000	3000	3000	3000	3000	3000 <sup>Ⓜ</sup>
<b>Short-Circuit Ratings</b> <sup>Ⓜ</sup> (Reference C37.04-1999 and C37.06-2009 except as noted <sup>Ⓜ</sup> )										
Symmetrical interrupting current (I) kA rms sym <sup>③</sup>	25	40	50	63	40	50	25	40	50	63
DC component (% DC) <sup>④</sup>	50	50	44	55	50	44	50	50	44	55
Asymmetrical interrupting current (I <sub>t</sub> ) kA rms asym total <sup>⑤</sup>	31	49	59	80	49	59	31	49	59	80
Closing and latching current (2.6 x I) kA peak	65	104	130	164	104	130	65	104	130	164
Short-time withstand current rms <sup>⑥</sup>	25	40	50	63	40	50	25	40	50	63
<b>Transient Recovery Voltage parameters are based on TD-4</b>										
Peak voltage (E <sub>2</sub> ) = (u <sub>c</sub> ) (kV peak)	8.2	8.2	8.2	8.2	14	14	28 <sup>Ⓜ</sup> , 25.7	25.7	25.7	28 <sup>Ⓜ</sup>
Time to peak (T <sub>2</sub> = t <sub>3</sub> x 1.137) (μsec)	50	50	50	50	59	59	75	75	75	75
TRV rise time (t <sub>3</sub> ) (μsec)	44	44	44	44	52	52	66	66	66	66
RRRV = u <sub>c</sub> /t <sub>3</sub> (kV/μsec) <sup>⑦</sup>	0.19	0.19	0.19	0.19	0.27	0.27	0.42, 0.39	0.39	0.39	0.42
Interrupting time ms	50	50	50	50	50	50	50	50	50	50
Cycles (60 Hz)	3	3	3	3	3	3	3	3	3	3
Operating duty (duty cycle)	0–0.3s– CO–3m–CO	0–0.3s– CO–3m–CO	0–0.3s– CO–3m–CO	0–0.3s– CO–3m–CO	0–0.3s– CO–3m–CO	0–0.3s– CO–3m–CO	0–0.3s– CO–3m–CO	0–0.3s– CO–3m–CO	0–0.3s– CO–3m–CO	0–0.3s– CO–3m–CO
Mechanical endurance no-load operations <sup>⑧⑨</sup>	10,000	10,000	10,000	10,000	10,000	10,000	10,000	10,000	10,000	10,000

**Notes**

- ① All circuit breakers are tested at 60 Hz, however, they can also be applied at 50 Hz with no de-rating.
- ② 4000A fan cooled rating is available for 3000A circuit breakers.
- ③ Because the voltage range factor K=1, the short-time withstand current and the maximum symmetrical interrupting current are equal to the rated symmetrical interrupting current.
- ④ Based on the standard DC time constant of 45 ms (corresponding to X/R of 17 for 60 Hz) and the minimum contact parting time as determined from the minimum opening time plus the assumed minimum relay time of 1/2 cycle (8.33 ms for 60 Hz).
- ⑤ The asymmetrical interrupting current, I total, is given by  $I_t = I \times \text{Sqrt}(1 + 2 \times \%DC \times \%DC)$  kA rms asym total.
- ⑥ Duration of short-time current and maximum permissible tripping delay are both 2 seconds for all circuit breakers listed in this table, as required in C37.04-1999, C37.06-2000 and C37.06-2009.
- ⑦ RRRV can also be calculated as  $= 1.137 \times E_2/T_2$ .
- ⑧ Each operation consists of one closing plus one opening.
- ⑨ All 40 and 50 kA circuit breakers exceed required 5000 no-load operations; all 63 kA circuit breakers exceed the required 2000 no-load ANSI operations.
- Ⓜ These circuit breakers were tested to the preferred TRV ratings specified in C37.06-2000.

## Available Type VCP-W Vacuum Circuit Breakers Rated on Symmetrical Current Basis Per ANSI Standards (Rated K=1), continued

Identification	Drawout Circuit Breaker Type									
	50 VCP-W25	50 VCP-W40	50 VCP-W50	50 VCP-W63	75 VCP-W40	75 VCP-W50	150 VCP-W25	150 VCP-W40	150 VCP-W50	150 VCP-W63
<b>Capacitance Current Switching Capability (Reference C37.04a-2003, C37.06-2009 and C37.09a-2005)</b>										
Cable-charging current Class	C2	C2	C2	C2	C2	C2	C2	C2	C2	C2
A rms	3-10	3-10	3-10	7.5-25	7.5-25	7.5-25	7.5-25	7.5-25	7.5-25	7.5-25
Isolated shunt capacitor bank current Class	C2	C2	C2	C2	C2	C2	C2, C2, C1	C2, C2, C1	C2, C2, C1	C2
A rms										
1200A	75-630	75-630	75-630	75-630	75-630	75-630	75-630	75-630	75-630	75-630
2000A	75-1000	75-1000	75-1000	75-1000	75-1000	75-1000	75-1000	75-1000	75-1000	75-1000
3000A	75-1600	75-1600	75-1600	75-1600	75-1600	75-1600	75-1600	75-1600	75-1600	75-1600
<b>Back-to-Back Capacitor Switching</b>										
Capacitor bank current Class	C2	C2	C2	C2	C2	C2	C2, C2, C1	C2, C2, C1	C2, C2, C1	C2
A rms										
1200A	75-630	75-630	75-630	75-630	75-630	75-630	75-630	75-630	75-630	75-630
2000A	75-1000	75-1000	75-1000	75-1000	75-1000	75-1000	75-1000	75-1000	75-1000	75-1000
3000A	75-1600	75-1600	75-1600	75-1600	75-1600	75-1600	75-1600	75-1600	75-1600	75-1600
Inrush current kA peak	6	6	6	6	6	6	6	6	6	6
Inrush frequency kHz										
1200A	0.8	0.8	0.8	0.8	0.8	0.8	0.8	0.8	0.8	0.8
2000A	0.5	0.5	0.5	0.5	0.5	0.5	0.5	0.5	0.5	0.5
3000A	0.3	0.3	0.3	0.3	0.3	0.3	0.3	0.3	0.3	0.3
<b>Out-of-Phase Switching</b>										
Voltage = 1.44 x V (kV rms)	7	7	7	7	12	12	22	22	22	22
Current = 0.25 x I (kA rms)	6.3	10	12.5	15.8	10	12.5	6.3	10	12.5	15.8

VCP-W Vacuum Breaker Types Rated on Symmetrical Current Rating Basis <sup>①</sup>

	Circuit Breaker Type							
	270 VCP-W750	270 VCP-W1000	270 VCP-W1250	270 VCP-W1600	270 VCP-W2000	270 VCP-W25C	270 VCP-W32C	270 VCP-W40C
<b>Identification</b>								
Nominal voltage class kV	27	27	27	27	27	27	27	27
Nominal three-phase MVA class	750	1000	1250	1600	2000	—	—	—
<b>Rated Values</b>								
<b>Voltage</b>								
Maximum voltage E kV rms	27 <sup>②</sup>	27 <sup>②</sup>	27 <sup>②</sup>	27 <sup>②</sup>	27 <sup>②</sup>	27	27	27
Voltage range factor K <sup>③</sup>	1.0	1.0	1.0	1.0	1.0	1.0	1.0	1.0
<b>Insulation Level</b>								
Withstand test voltage								
Power frequency (1 min.) kV rms	60	60	60	60	60	60	60	60
Impulse kV peak	125	125	125	125	125	125	125	125
<b>Current</b>								
Continuous current at 60 Hz amperes	600	600	600	1200	1200	1200	1200	1200
	1200	1200	1200	2000	2000	1600	1600	1600
	2000	2000	2000	—	—	—	—	—
Short-circuit current (at rated maximum kV) <sup>④⑤</sup>	16	22	25	25	40	25 <sup>⑦</sup>	31.5 <sup>⑧</sup>	40 <sup>⑧</sup>
Interrupting time ms (cycles)	83 (5) <sup>⑥</sup>	83 (5) <sup>⑥</sup>	83 (5) <sup>⑥</sup>	83 (5) <sup>⑥</sup>	83 (5) <sup>⑥</sup>	50 (3)	50 (3)	50 (3)
Maximum permissible tripping delay Y seconds	2	2	2	2	2	2.5	1.6	1.0
Transient recovery voltage								
E <sub>2</sub> kV peak	51	51	51	51	51	50	50	50
T <sub>2</sub> μs	105	105	105	105	105	50	50	50
<b>Current Values</b>								
Closing and latching capability (2.6 K times rated short-circuit current) kA peak	43	60	68	85	106	85	100	112
Capacitor switching cable charging amperes	31.5	31.5	31.5	31.5	31.5	31.5	31.5	31.5
<b>Weight Lbs (kg)</b>								
600A	460 (209)	460 (209)	460 (209)	545 (247)	545 (247)	545 (247)	545 (247)	545 (247)
1200A	480 (218)	480 (218)	480 (218)	560 (254)	600 (272)	560 (254)	560 (254)	560 (254)
2000A	500 (227)	500 (227)	500 (227)	—	—	—	—	—

**Notes**

<sup>①</sup> CESI tested to applicable ANSI standards C37.04, C37.09 and C37.06. Consult Eaton for CESI copies of test reports on file. Operating duty cycle CO-15 seconds-CO. Operating time values: Opening 33–55 ms, closing 50–60 ms and reclosing 18 cycles (300 ms).

<sup>②</sup> Tested at 28.5 kV.

<sup>③</sup> K = 1.0, therefore E = E/K and I = KI.

<sup>④</sup> Also maximum interrupting rating and short-time current rating.

<sup>⑤</sup> Duration of short-time current = 3 seconds, except as noted in footnotes 7, 8 and 9.

<sup>⑥</sup> Optional interrupting time of 50 ms (3 cycles) is available.

<sup>⑦</sup> Duration of short-time current = 2.5 seconds.

<sup>⑧</sup> Duration of short-time current = 1.6 seconds.

<sup>⑨</sup> Duration of short-time current = 1 second.

## Type VCP-W Vacuum Circuit Breaker Ratings

Type VCP-W Ratings on Symmetrical Current Rating Basis <sup>①②</sup>

Identification	Circuit Breaker Type				
	380 VCP-W 6 and 380 VCP-WR 16	380 VCP-W 25 and 380 VCP-WR 25	380 VCP-W 32 and 380 VCP-WR 32	380 VCP-W 21 and 380 VCP-WR 21	380 VCP-W 40 and 380 VCP-WR 40
<b>Rated Values</b>					
<b>Voltage</b>					
Nominal voltage class kV rms	34.5	34.5	34.5	34.5	34.5
Maximum voltage V kV rms	38	38	38	38	38
Voltage range factor K <sup>③</sup>	1	1	1	1.65 <sup>④</sup>	1
V/K <sup>⑤</sup> kV rms	38	38	38	23 <sup>⑥</sup>	38
<b>Insulation Level Withstand Test</b>					
Power frequency (1 minute) kV rms	80	80	80	80	80
Lightning impulse 1.2 x 50 <sup>④</sup> kV peak	170	170	170	170	170
<b>Current</b>					
Continuous current at 60 Hz <sup>⑦</sup> A rms	600	600	600	1200	1200
	1200	1200	1200	2000	2000
	1600	1600	1600	3000FC	3000FC
	2000	2000	2000	2500	2500
	—	—	3000FC	—	—
	—	—	2500	—	—
<b>Short-Circuit Current</b>					
Sym. interrupting at V (I <sub>sc</sub> ) kA rms	16	25	31.5	21	40
% DC component (I <sub>dc</sub> )	47	47	47	47	47
Asym. factor S (ref.)	1.2	1.2	1.2	1.2	1.2
Asym. interrupting (I <sub>sc</sub> ) kA rms total	19.2	30.0	37.8	39.5	48.0
Maximum asym. interrupting at V/K (KxI <sub>sc</sub> ) <sup>③</sup> kA rms	16	25	31.5	35 <sup>⑧</sup>	40
Maximum asym. interrupting at V/K (SxKxI <sub>sc</sub> ) <sup>③</sup> kA rms total	19.3	30.0	37.8	42.0	48.0
Closing and latching capability kA peak	43	68	85	95	107
Momentary current withstand capability kA rms total	26	40	50	56	63
Short-time current kA rms	16	25	31.5	35	40
Duration of short-time current s	3	3	3	3	3
Operating duty (duty cycle)	⑨⑩	⑨⑩	⑨⑩ (2500 only ⑨⑩)	⑨⑩ (2500 only ⑨⑩)	⑨⑩
Rated reclosing factor (R) %	100	100	100 (2500 only 0%)	100 (2500 only 0%)	100
<b>Interrupting time <sup>⑥</sup></b>					
rms	83	83	83	83	83
Cycle	5	5	5	5	5
Maximum permissible tripping delay sec.	2	2	2	2	2
Transient recovery voltage (RRRV) kV/μs	0.6	0.6	0.6	0.6	0.6
Mechanical endurance <sup>⑦</sup>	2000	2000	2000	2000	2000

**Notes**

- ① KEEMA tested to applicable ANSI standards C37.04-1979, C37.09-1979 and C37.06-1979 (operating duty sequence CO-15s-CO). Typical operating time values: operating 45 ms, closing 75 ms and reclosing 300 ms (18 cycles).
- ② The standard breaker is not rated for capacitor switching. If you require capacitor switching, please refer to the "C" breakers.
- ③ K = 1.0, therefore E = E/K and I = KI. Refer to the *Consulting Application Guide* for more information.
- ④ The ANSI C37.06 standard requires 150 kV BIL. If higher BIL levels are required, please refer to the "C" breakers.
- ⑤ For forced air cooled fixed breaker applications, consult Eaton.
- ⑥ If you require 50 ms (3 cycle) interrupting time, please refer to the "C" breakers.
- ⑦ No-load operations.
- ⑧ At 23 kV rms (rated maximum voltage/K). Rated maximum symmetrical interrupting capability = 35 kA rms (K x 1).
- ⑨ CO-15s-CO.
- ⑩ Rated and tested also for rapid reclosing capability 0-0.3s-CO.
- ⑪ Not rated for rapid reclosing.

**Type VCP-WC Vacuum Circuit Breaker Ratings****Type VCP-WC Ratings on Symmetrical Current Rating Basis <sup>①②</sup>**

Identification	Drawout Circuit Breaker Type				
	380 VCP-W 16C and 380 VCP-WR 16C	380 VCP-W 25C and 380 VCP-WR 25C	380 VCP-W 32C and 380 VCP-WR 32C	380 VCP-W 21C and 380 VCP-WR 21C	380 VCP-W 40C and 380 VCP-WR 40C
<b>Rated Values</b>					
<b>Voltage</b>					
Nominal voltage class kV rms	34.5	34.5	34.5	34.5	34.5
Maximum voltage V kV rms	38	38	38	38	38
Voltage range factor K <sup>③</sup>	1	1	1	1.65 <sup>⑥</sup>	1
V/K <sup>③</sup> kV rms	38	38	38	23 <sup>⑥</sup>	38
<b>Insulation Level Withstand Test</b>					
Power frequency (1 minute) kV rms	80	80	80	80	80
Lightning impulse 1.2 x 50 $\mu$ s <sup>④</sup> kV peak	170	170	170	170	170
<b>Current</b>					
Continuous current at 60 Hz <sup>⑤</sup> A rms	600	600	600	1200	1200
	1200	1200	1200	2000	2000
	1600	1600	1600	3000FC	3000FC
	2000	2000	2000	2500	2500
	—	—	3000FC	—	—
	—	—	2500	—	—
<b>Short-Circuit Current</b>					
Sym. interrupting at V (Isc) kA rms	16	25	33.1	21	40
% DC component (I <sub>dc</sub> )	75	65	57	52	63
Asym. factor S (ref.)	1.46	1.36	1.3	1.24	1.34
Asym. interrupting (I <sub>l</sub> ) kA rms total	23.3	34.0	42.5	26.1	53.5
Maximum sym. interrupting at V/K (K <sub>xlsc</sub> ) <sup>③</sup> kA rms	16	25	33.1	35 <sup>⑥</sup>	40
Maximum asym. interrupting at V/K (S <sub>x</sub> K <sub>xlsc</sub> ) <sup>③</sup> kA rms total	23.3	34.0	42.5	43.4	53.5
Closing and latching capability kA peak	50	75	91	102	107
Momentary current withstand capability kA rms total	30	44	54	60	65
Short-time current kA rms	16	25	31.5	35	40
Duration of short-time current s	3.09	3.09	3.09	3.21	3.04
Operating duty (duty cycle)	⑧⑨	⑧⑨	⑧⑨ (2500A <sup>⑩</sup> )	⑧⑨ (2500A <sup>⑩</sup> )	⑧⑨
Rapid reclosing factor (R) %	100	100	100 (2500A N/A)	100 (2500A N/A)	—
Interrupting time <sup>⑦</sup> rms	50	50	50	50	50
Cycles	3	3	3	3	3
Maximum permissible tripping delay sec.	2	2	2	2	2
Transient recovery voltage (RRRV) kV/ $\mu$ s	0.7	0.7	0.7	0.7	—
	1.3	1.3	0.7	1.3	—
	—	—	0.7	1.3	—
	—	—	1.3	0.7	—
	—	—	1.3	—	—
	—	—	0.7	—	—

**Notes**

- ① KEMA tested to applicable ANSI standards C37.04-1979, C37.09-1979 and C37.06-1979 (operating duty sequence CO–15s–CO). Typical operating time values: operating 45 ms, closing 75 ms and reclosing 300 ms (18 cycles).
- ② The standard breaker is not rated for capacitor switching. If you require capacitor switching, please refer to the “C” breakers.
- ③  $K = 1.0$ , therefore  $E = E/K$  and  $I = KI$ . Refer to the *Consulting Application Guide* for more information.
- ④ The ANSI C37.06 standard requires 150 kV BIL. If higher BIL levels are required, please refer to the “C” breakers.
- ⑤ For forced air cooled fixed breaker applications, consult Eaton.
- ⑥ If you require 50 ms (3 cycle) interrupting time, please refer to the “C” breakers.
- ⑦ No-load operations.
- ⑧ At 23 kV rms (rated maximum voltage/K). Rated maximum symmetrical interrupting capability = 35 kA rms ( $K \times 1$ ).
- ⑨ CO–15s–CO.
- ⑩ Rated and tested also for rapid reclosing capability 0–0.3s–CO.
- ⑪ Not rated for rapid reclosing.

**Type VCP-WC Vacuum Circuit Breaker Ratings****Type VCP-WC Ratings on Symmetrical Current Rating Basis, continued<sup>①②</sup>**

Identification	Drawout Circuit Breaker Type				
	380 VCP-W 16C and 380 VCP-WR 16C	380 VCP-W 25C and 380 VCP-WR 25C	380 VCP-W 32C and 380 VCP-WR 32C	380 VCP-W 21C and 380 VCP-WR 21C	380 VCP-W 40C and 380 VCP-WR 40C
<b>Capacitor Switching Ratings</b>					
<b>Definite Purpose</b>					
Overhead line current A rms	5	5	5 (2500A N/A)	5 (2500A N/A)	—
Isolated shunt capacitor bank current A rms	250	250	250	250	—
	250 and 1000 (2000A)	250 and 1000 (2000A)	250 and 1000 (2000A and 3000FC) (2500 N/A)	250 and 1000 (2000A and 3000FC) (2500 N/A)	—
<b>Definite Purpose—Back-to-Back Capacitor Switching</b>					
Cable charging current A rms	56	56	53	53	53
Capacitor bank current A rms	250	250	250	250	—
	250 and 1000 (200A)	250 and 1000 (200A)	250 and 1000 (2000A and 3000FC) (2500 N/A)	250 and 1000 (2000A and 3000FC) (2500 N/A)	—
Inrush current kA peak	20	20	20	20	—
	20 and 20 (2000A)	20 and 20 (2000A)	20 and 20 (2000A and 3000FC) (2500 N/A)	20 and 20 (2000A and 3000FC) (2500 N/A)	—
Inrush frequency kHz	4.4	4.4	4.4	4.4	—
	5 and 5 (2000A)	5 and 5 (2000A)	5 and 5 (2000A and 3000FC) (2500 N/A)	5 and 5 (2000A and 3000FC) (2500 N/A)	—
Mechanical endurance (no-load operations) <sup>②</sup>	15,000	15,000	15,000	15,000	15,000



**IEC Standards****IEC Standards ①—VCP-W Vacuum Circuit Breaker Types Rated on Symmetrical Current Rating Basis**

Identification	Rated Values							
	Circuit Breaker Type	Voltage kV rms	Insulation Level Power Frequency kV rms Peak	Impulse Withstand kV Peak	Normal Current Amperes	Short-Circuit Breaking Current and 3-Second Short-Time Current kA rms	Short-Circuit Making Current kV Peak	Cable Charging Breaking Current Amperes
36 VCP-WND25	3.6	10	40	630	25	65	10	350 (159)
	3.6	10	40	1250	25	65	10	350 (159)
36 VCP-WND32	3.6	10	40	630	31.5	82	10	350 (159)
	3.6	10	40	1250	31.5	82	10	350 (159)
72 VCP-WND25	7.2	20	60	630	25	65	10	350 (159)
	7.2	20	60	1250	25	65	10	350 (159)
72 VCP-WND32	7.2	20	60	630	31.5	82	10	350 (159)
	7.2	20	60	1250	31.5	82	10	350 (159)
36 VCP-W25	3.6	10	40	630	25	65	10	414 (188)
	3.6	10	40	1250	25	65	10	430 (195)
	3.6	10	40	2000	25	65	10	496 (225)
36 VCP-W32	3.6	10	40	1250	31.5	82	10	414 (188)
	3.6	10	40	2000	31.5	82	10	496 (225)
36 VCP-W40	3.6	10	40	1250	40	104	10	496 (225)
	3.6	10	40	2000	40	104	10	550 (250)
72 VCP-W25	7.2	20	60	630	25	65	10	414 (188)
	7.2	20	60	1250	25	65	10	414 (188)
	7.2	20	60	2000	25	65	10	496 (225)
72 VCP-W32	7.2	20	60	1250	31.5	82	10	414 (188)
	7.2	20	60	2000	31.5	82	10	430 (195)
72 VCP-W40	7.2	20	60	1250	40	104	10	430 (195)
	7.2	20	60	2000	40	104	10	496 (225)
120 VCP-W25	12.0	28	75	630	25	65	25	430 (195)
	12.0	28	75	1250	25	65	25	496 (225)
	12.0	28	75	2000	25	65	25	496 (225)
120 VCP-W32	12.0	28	75	1250	31.5	82	25	430 (195)
	12.0	28	75	2000	31.5	82	25	496 (225)
120 VCP-W40	12.0	28	75	1250	40	104	25	496 (225)
	12.0	28	75	2000	40	104	25	550 (250)
175 VCP-W25	17.5	38	95	630	25	65	—	430 (195)
	17.5	38	95	1250	25	65	—	496 (225)
	17.5	38	95	2000	25	65	—	496 (225)
175 VCP-W32	17.5	38	95	1250	31.5	82	—	430 (195)
	17.5	38	95	2000	31.5	82	—	496 (225)
175 VCP-W40	17.5	38	95	1250	40	104	—	496 (225)
	17.5	38	95	2000	40	104	—	550 (250)
175 VCP-W50	17.5	38	95	1250	50	130	—	1013 (460)
	17.5	38	95	2000	50	130	—	1079 (490)
	17.5	38	95	3150	50	130	—	1156 (525)

**Note**

① IEC Standards 60056 and 60694 apply.

## ANSI Standard Ratings—VCP-T and VCP-TR Vacuum Circuit Breakers (to ANSI C37.04 and C37.09)

Identification	Rated Values						
	Voltage Class kV rms	Insulation Level Power Frequency kV rms	Impulse Withstand kV Peak	Continuous Current Amperes	Short-Circuit <sup>③</sup> Breaking Current kA rms	Short-Circuit Making Current kA Peak	Mechanical Endurance C-0 Operations
50 VCP-T16 and 50 VCP-TR16	4.76	19	60	600	16	42	20,000
	4.76	19	60	800	16	42	20,000
	4.76	19	60	1200	16	42	10,000
	4.76	19	60	1600 <sup>②</sup>	16	42	10,000
50 VCP-T20 and 50 VCP-TR20	4.6	19	60	600	16	52	10,000
	4.6	19	60	800	16	52	10,000
	4.6	19	60	1200	16	52	10,000
	4.6	19	60	1600 <sup>②</sup>	16	52	10,000
50 VCP-T25 and 50 VCP-TR25	4.76	19	60	600	25	65	10,000
	4.76	19	60	800	25	65	10,000
	4.76	19	60	1200	25	65	10,000
	4.76	19	60	1600 <sup>②</sup>	25	65	10,000
75 VCP-T16 and 75 VCP-TR16	8.25	20	60 <sup>①</sup>	600	16	42	20,000
	8.25	20	60 <sup>①</sup>	800	16	42	20,000
	8.25	20	60 <sup>①</sup>	1200	16	42	10,000
	8.25	20	60 <sup>①</sup>	1600 <sup>②</sup>	16	42	10,000
75 VCP-T20 and 75 VCP-TR20	8.25	20	60 <sup>①</sup>	600	20	52	10,000
	8.25	20	60 <sup>①</sup>	800	20	52	10,000
	8.25	20	60 <sup>①</sup>	1200	20	52	10,000
	8.25	20	60 <sup>①</sup>	1600 <sup>②</sup>	20	52	10,000
75 VCP-T25 and 75 VCP-TR25	8.25	20	60 <sup>①</sup>	600	25	65	10,000
	8.25	20	60 <sup>①</sup>	800	25	65	10,000
	8.25	20	60 <sup>①</sup>	1200	25	65	10,000
	8.25	20	60 <sup>①</sup>	1600 <sup>②</sup>	25	65	10,000
150 VCP-T16 and 150 VCP-TR16	15	36	95	600	16	42	10,000
	15	36	95	800	16	42	10,000
	15	36	95	1200	16	42	10,000
	15	36	95	1600 <sup>②</sup>	16	42	10,000
150 VCP-T20 and 150 VCP-TR20	15	36	95	600	20	52	10,000
	15	36	95	800	20	52	10,000
	15	36	95	1200	20	52	10,000
	15	36	95	1600 <sup>②</sup>	20	52	10,000
150 VCP-T25 and 150 VCP-TR25	15	36	95	600	25	65	10,000
	15	36	95	800	25	65	10,000
	15	36	95	1200	25	65	10,000
	15	36	95	1600 <sup>②</sup>	25	65	10,000

**Notes**

- ① Use 15 kV breaker and cassette when 95 kV impulse withstand required.  
 ② 1600A VCP-T breaker available.  
 ③ Also 2 second short-time current rating.

## ANSI Standard Ratings—VCP-TL/VCP-TRL Vacuum Circuit Breakers (to ANSI C37.04 and C37.09)

Identification  Circuit Breaker Type ①	Rated Values			Continuous Current Amperes	Short-Circuit Breaking Current ② kA rms	Short-Circuit Making Current kA Peak	Mechanical Endurance ③ C-0 Operations	Approx. Weight Fix/Drawout (Pounds)
	Rated Maximum Voltage kV rms	Insulation Level Power Frequency kV rms	Impulse Withstand kV Peak					
50 VCP-TL16 and 50 VCP-TRL16	4.76	19	60	600	16	42	100,000	153/232
				1200	16	42	100,000	155/234
				1600 ④	16	42	100,000	157/NA
50 VCP-TL20 and 50 VCP-TRL20	4.76	19	60	600	20	52	100,000	159/237
				1200	20	52	100,000	161/239
				1600 ④	20	52	100,000	163/NA
50 VCP-TL25 and 50 VCP-TRL25	4.76	19	60	600	25	65	100,000	166/243
				1200	25	65	100,000	168/245
				1600 ④	25	65	100,000	170/NA
75 VCP-TL16 and 75 VCP-TRL16	8.25	20	75 ⑤	600	16	42	100,000	155/232
				1200	16	42	100,000	157/234
				1600 ④	16	42	100,000	159/NA
75 VCP-TL20 and 75 VCP-TRL20	8.25	20	75 ⑤	600	20	52	100,000	161/239
				1200	20	52	100,000	161/241
				1600 ④	20	52	100,000	163/NA
75 VCP-TL25 and 75 VCP-TRL25	8.25	20	75 ⑤	600	25	65	100,000	166/245
				1200	25	65	100,000	168/247
				1600 ④	25	65	100,000	170/NA
150 VCP-TL16 and 150 VCP-TRL16	15	36	95	600	16	42	100,000	155/234
				1200	16	42	100,000	157/237
				1600 ④	16	42	100,000	159/NA
150 VCP-TL20 and 150 VCP-TRL20	15	36	95	600	20	52	100,000	161/239
				1200	20	52	100,000	163/241
				1600 ④	20	52	100,000	166/NA
150 VCP-TL25 and 150 VCP-TRL25	15	36	95	600	25	65	100,000	168/245
				1200	25	65	100,000	170/247
				1600 ④	25	65	100,000	172/NA

**Notes**

- ① Independent shunt trips are available for use with traditional protective relaying schemes.  
 ② Also 2-second short-time current rating.  
 ③ Operating mechanism up to 100,000 operations, vacuum interrupter 30,000.  
 ④ 1600A available as fixed VCP-TRL/VCP-TRLC circuit breaker only.  
 ⑤ Use 15 kV breaker and cassette when impulse withstand >75 kV is required.

## IEC Standard Ratings—T-VAC and T-VACR Vacuum Circuit Breakers (to IEC 62271-100)

Identification	Rated Values						
	Circuit Breaker Type	Voltage Class kV rms	Insulation Level		Normal Current ( $I_n$ ) Amperes	Short-Circuit <sup>③</sup> Breaking Current kA rms	Short-Circuit Making Current kA Peak
Power Frequency Withstand Voltage kV rms			Lightning Impulse ( $U_w$ ) Withstand Voltage kV Peak				
72 T-VAC16 and 72 T-VACR16	7.2	20	60	630	16	40	20,000
	7.2	20	60	800	16	40	20,000
	7.2	20	60	1250	16	40	10,000
	7.2	20	60	1600 <sup>②</sup>	16	40	10,000
72 T-VAC20 and 72 T-VACR20	7.2	20	60	630	20	50	10,000
	7.2	20	60	800	20	50	10,000
	7.2	20	60	1250	20	50	10,000
	7.2	20	60	1600 <sup>②</sup>	20	50	10,000
72 T-VAC25 and 72 T-VACR25	7.2	20	60	630	25	63	10,000
	7.2	20	60	800	25	63	10,000
	7.2	20	60	1250	25	63	10,000
	7.2	20	60	1600 <sup>②</sup>	25	63	10,000
120 T-VAC16 and 120 T-VACR16	12	28	75 <sup>①</sup>	630	16	40	20,000
	12	28	75 <sup>①</sup>	800	16	40	20,000
	12	28	75 <sup>①</sup>	1250	16	40	10,000
	12	28	75 <sup>①</sup>	1600 <sup>②</sup>	16	40	10,000
120 T-VAC20 and 120 T-VACR20	12	28	75 <sup>①</sup>	630	20	50	10,000
	12	28	75 <sup>①</sup>	800	20	50	10,000
	12	28	75 <sup>①</sup>	1250	20	50	10,000
	12	28	75 <sup>①</sup>	1600 <sup>②</sup>	20	50	10,000
120 T-VAC25 and 120 T-VACR25	12	28	75 <sup>①</sup>	630	25	63	10,000
	12	28	75 <sup>①</sup>	800	25	63	10,000
	12	28	75 <sup>①</sup>	1250	25	63	10,000
	12	28	75 <sup>①</sup>	1600 <sup>②</sup>	25	63	10,000
175 T-VAC16 and 175 T-VACR16	17.5	38	95	630	16	40	10,000
	17.5	38	95	800	16	40	10,000
	17.5	38	95	1250	16	40	10,000
	17.5	38	95	1600 <sup>②</sup>	16	40	10,000
175 T-VAC20 and 175 T-VACR20	17.5	38	95	630	20	50	10,000
	17.5	38	95	800	20	50	10,000
	17.5	38	95	1250	20	50	10,000
	17.5	38	95	1600 <sup>②</sup>	20	50	10,000
175 T-VAC25 and 175 T-VACR25	17.5	38	95	630	25	63	10,000
	17.5	38	95	800	25	63	10,000
	17.5	38	95	1250	25	63	10,000
	17.5	38	95	1600 <sup>②</sup>	25	63	10,000

**Notes**

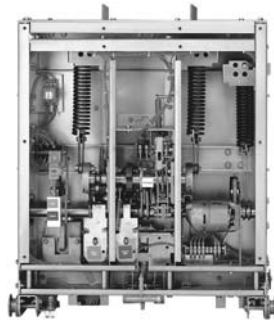
- ① Use 17.5 kV breaker and cassette when 95 kV impulse withstand required.  
 ② 1600A T-VAC breaker available.  
 ③ Also 3-second short-time current rating.

**Dimensions**

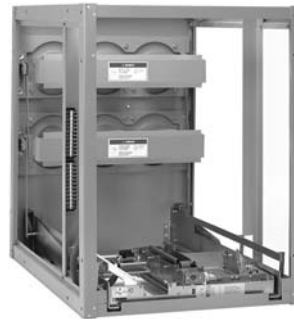
Approximate Dimensions in Inches (mm)



Type VCP-W Circuit Breaker Shown from Rear



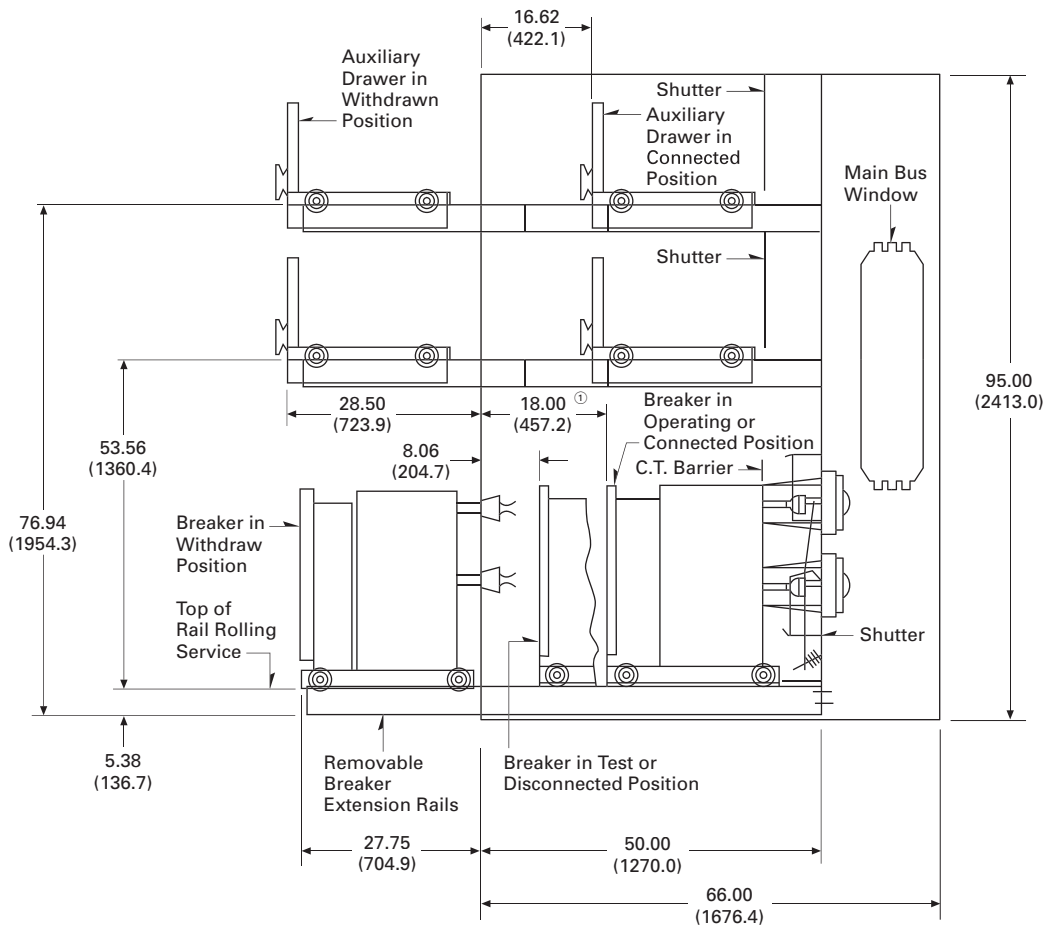
Type VCP-W Circuit Breaker with Deadfront Panel Removed



Mini Module

**5/15 kV VCPW-ND and VCP-W Power Modules**

Power Module, 5/15 kV VCPW-ND 26.00 (660.4) Wide, VCP-W 36.00 (914.4) Wide



**Note**

① VCPW-ND dimensions of breaker travel 15.00 (381.0).

# 26.1

## Power Breakers, Contactors and Fuses

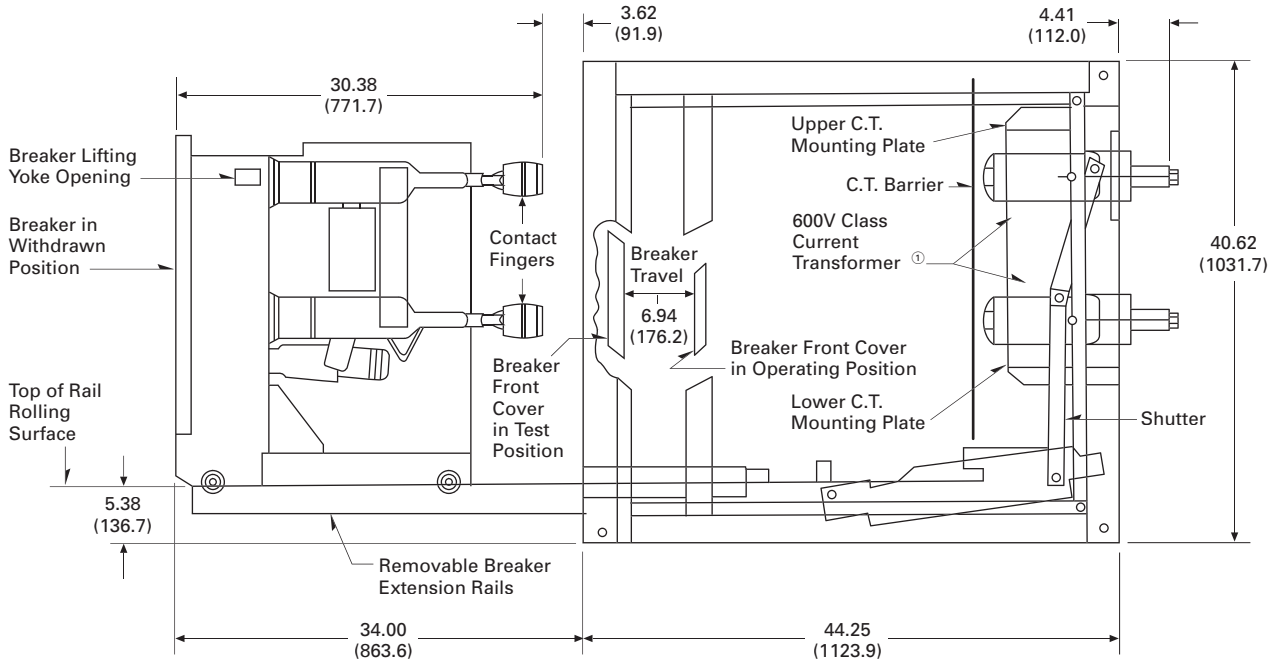
### Power Circuit Breakers

Approximate Dimensions in Inches (mm)

#### 5/15 kV VCPW-ND and VCP-W Mini Modules

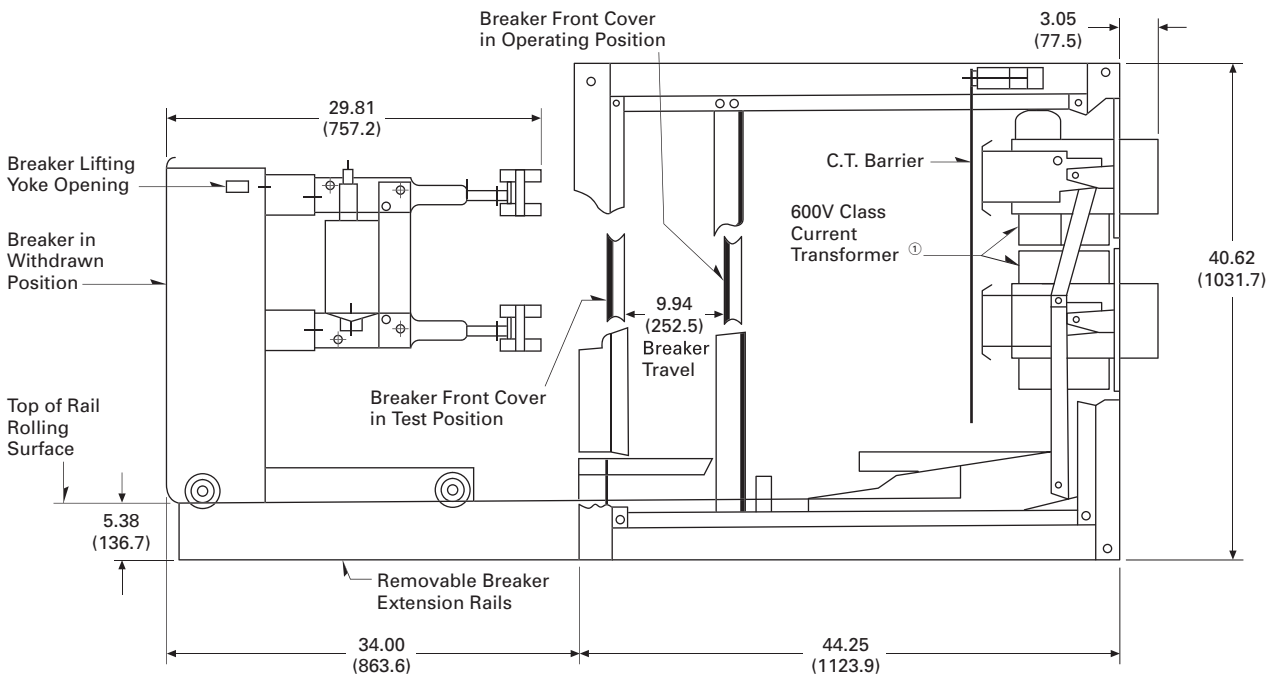
26

#### 5 kV VCPW-ND Mini Module 25.88 (657.4) Wide



#### 5/15 kV VCP-W Mini Module

#### 5/15 kV VCP-W Mini-Module 35.88 (911.4) Wide



**Note**

① Current transformers not supplied.

**Contents**

<i>Description</i>	<i>Page</i>
Catalog Number Selection . . . . .	<b>V4-T26-52</b>
SL MV Power Contactor 7.2 kV/160–400A . . . . .	<b>V4-T26-53</b>
SL MV Power Contactor 7.2 kV/800A . . . . .	<b>V4-T26-62</b>
SL MV Power Contactor 15 kV/250A . . . . .	<b>V4-T26-66</b>

**Product Overview**

**Voltage Class**

Eaton’s SL Medium Voltage Vacuum Contactors are designed to operate at voltages from 2200 to 15,000V, depending on contactor type. Typical system voltages are 2400, 3300, 4160 and 6600V for 7.2 kV contactors and 10,000, 11,000, 13,200 and 13,800V for 15 kV contactors.

**Altitude**

7.2 kV/160–400A SL Contactors are capable of operating in virtually any altitude range. Three versions are offered in Standard, High and Low altitude configurations. No de-rating is necessary for proper operation. Altitude designations are listed in the table below.

**Altitude**

Altitude	Low	Standard	High
<b>7.2 kV/160–400A</b>			
Feet	–11,500 to –3300	–3300 to +6600	+6600 to +13,100
Meters	–3500 to –1000	–1000 to +2000	+2000 to +4000
<b>7.2 kV/800A and 15 kV/250A</b>			
Feet	N/A	–3300 to +11,800	+11,800 to +16,000
Meters	N/A	–1000 to +3600	+3600 to +4900

**Control Voltage**

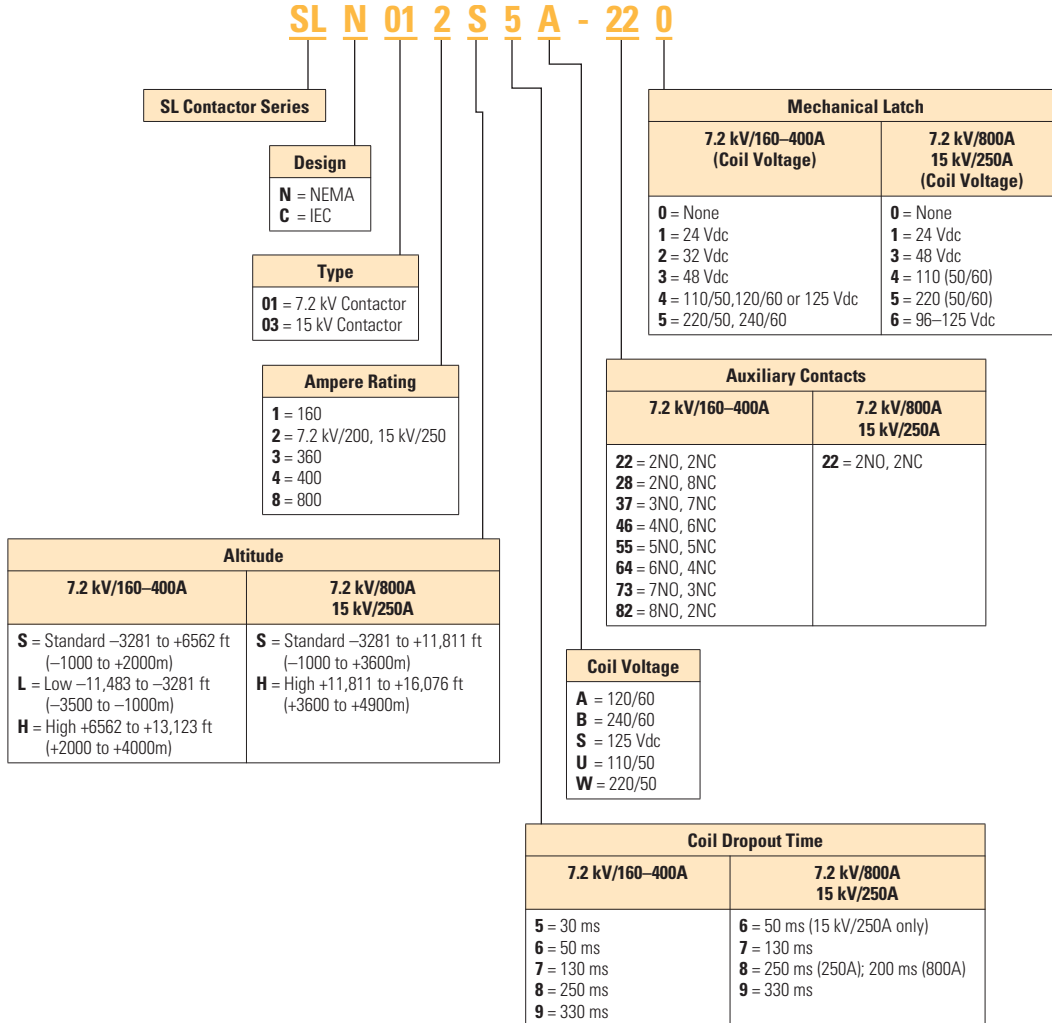
Control coil voltage should be selectable in the field. Standard voltages available should be 120/60, 110/50, 240/60, 220/50 and 125 Vdc. Coil should pickup at 80% of rated coil voltage and dropout not sooner than 60% of rated coil voltage. Opening time should be field selectable within the range of 30 ms–330 ms for 7.2 kV/160–400A and 50–330 ms for 15 kV/250A. Opening time for 7.2 kV/800A must be specified at order entry and can be either 130 ms, 250 ms or 330 ms.



#### Catalog Number Selection

#### Power Contactors

26



SL 7.2 kV/160–400A Medium Voltage Contactor



**Contents**

<i>Description</i>	<i>Page</i>
Product Overview . . . . .	V4-T26-51
SL MV Power Contactor 7.2 kV/160–400A	
Standards and Certifications . . . . .	V4-T26-55
Product Selection . . . . .	V4-T26-55
Options and Accessories . . . . .	V4-T26-55
Technical Data and Specifications . . . . .	V4-T26-56
Wiring Diagrams . . . . .	V4-T26-59
Dimensions . . . . .	V4-T26-60
SL MV Power Contactor 7.2 kV/800A . . . . .	V4-T26-62
SL MV Power Contactor 15 kV/250A . . . . .	V4-T26-66

**SL MV Power Contactor 7.2 kV/160–400A**

**Product Description**

- A single family of contactors for any medium voltage control application. Voltage range of 2200–7200V
- Ampere ratings from 160–400A with induction motor horsepower ranges from 600–5500 hp
- Three different altitude versions
- Leading-edge vacuum technology
- Fully complies with global standards

**Application Description**

***Eaton's SL Medium Voltage Contactor starting applications:***

- Squirrel-cage induction motors
- Synchronous motors
- Wound-rotor

***Fully applicable to:***

- Full voltage starting
- Reduced voltage starting

***The perfect choice for harsh duty applications:***

- Mining
- Pulp and paper
- HVAC
- Petrochemical
- Automotive
- Many others

**Features, Benefits and Functions**

- Long life—300,000 electrical and over 2 million mechanical
- Mounting flexibility—panel or pedestal mounting provisions are standard. Unit can be mounted in horizontal or vertical position
- Field-selectable settings for coil voltage, AC/DC, and coil dropout time
- Field kits available for auxiliary contacts and mechanical latch. Accessories are common for all sizes
- Special ordering allows unit to be factory pre-set to customer specification, including field kit installation
- Highest quality available—all contactors manufactured within state-of-the-art "ISO-Certified" facilities. 100% made in America

***Easy-to-Install Option Kits (Field Addition)***

- Up to six extra auxiliary contacts
- Mechanical latch—many coil voltages

***Long Life Guarantees High Quality***

- 300,000 electrical operations
- 2.5 million mechanical operations

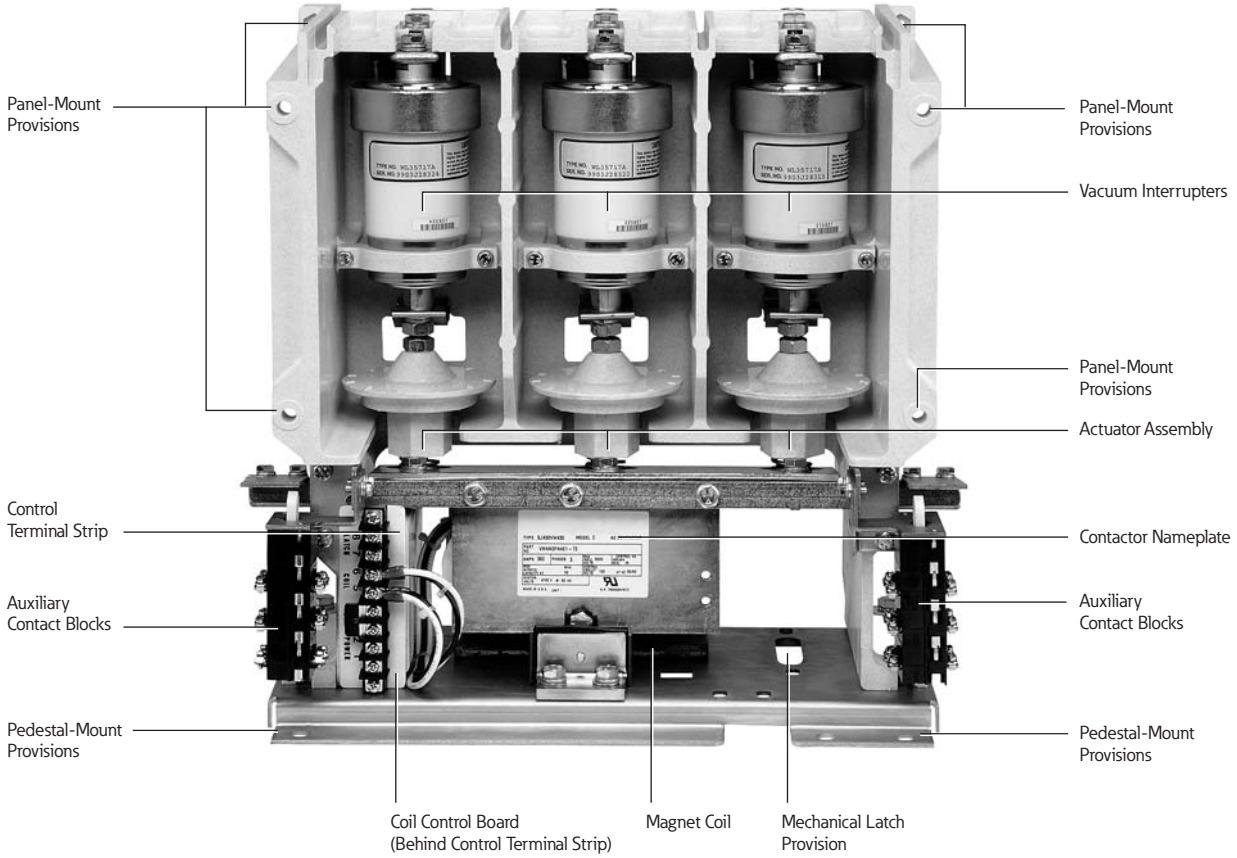
# 26.2

## Power Breakers, Contactors and Fuses

### Medium Voltage Power Contactors

#### SL Series Features (7.2 kV/160–400A)

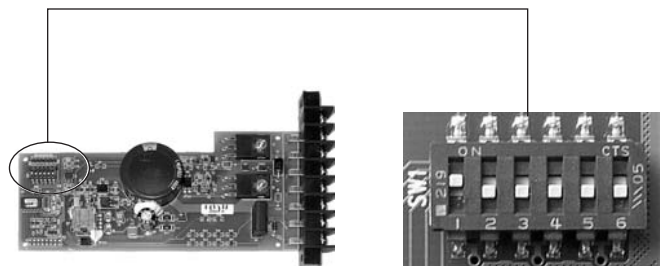
26



#### Control Settings



Control Terminal Strip



Coil Control Board

DIP Switches

### Standards and Certifications

#### Global Acceptability

- NEMA
- ANSI
- IEC

#### Third-Party Verification

- UL
- CSA
- KEMA
- Third-party qualified by UL, CSA, KEMA

#### Design and Test Standards

- UL 347, File No. E63257
- CSA T.I.L. D-21, File No. LR28548
- IEC No. 60470
- ANSI/NEMA ICS 3



### Product Selection

Contact Eaton for pricing.

### Options and Accessories

#### SL Vacuum Contactor Series—Sizes 7.2 kV/160–400A Accessory Kits

##### Mechanical Latch Kit

Field Mount to 7.2 kV/60–400A SL Vacuum Contactor. Coil voltages available in a wide range of AC and DC selections. Easy to install on new and existing units.



Mechanical Latch Kit

##### Auxiliary Contact Kit

Field Mount auxiliary contact kits for 7.2 kV/160–400A SL Vacuum Contactor. Contact kits are available in many configurations of NO-NC.



Auxiliary Contact Kit

##### Mechanical Interlock Kit

Field Mount mechanical interlock kits for 7.2 kV/160–400A SL Vacuum Contactor.



Mechanical Interlock Kit

#### Ordering Information—Mechanical Latch Kit

Coil Voltage	Catalog Number
24 Vdc	<b>SLA-ML24</b>
32 Vdc	<b>SLA-ML32</b>
48 Vdc	<b>SLA-ML48</b>
110/50, 120/60, 125 Vdc selectable	<b>SLA-ML120</b>
220/50, 240/60 selectable	<b>SLA-ML240</b>

#### Ordering Information—Auxiliary Contact Kit

Description	Catalog Number
3NO–3NC additional	<b>SLA-AS33</b>
6NO additional	<b>SLA-AS60</b>
6NC additional	<b>SLA-AS06</b>
5NO–1NC additional	<b>SLA-AS51</b>
4NO–2NC additional	<b>SLA-AS42</b>
2NO–4NC additional	<b>SLA-AS24</b>
1NO–5NC additional	<b>SLA-AS15</b>

#### Ordering Information—Mechanical Interlock Kit

Description	Catalog Number
Vertical or horizontal arrangement	<b>SLA-MI</b>

#### Note

#### Technical Data and Specifications

##### The SL Contactor Ratings

- Voltages of 2200–7200V
- Amperages from 160–400A
- Interrupting ratings as high as 8500A

##### Control Voltages (Field Adjustable)

- 110, 220 Vac, 50 Hz
- 120, 240 Vac, 60 Hz
- 125 Vdc

##### Dropout Time (Field Adjustable)

- 30 ms
- 50 ms
- 130 ms
- 250 ms
- 330 ms

#### Front and Rear View (7.2 kV/160–400A)



Front View



Rear View

#### Control Voltage Settings (7.2 kV/160–400A)

Setting	SW1	SW2	SW3
110 Vac, 50 Hz	Off	Off	Off
120 Vac, 60 Hz	On	Off	Off
220 Vac, 50 Hz	Off	On	Off
240 Vac, 60 Hz	On	On	Off
125 Vdc	Off	Off	On

#### Dropout Time Settings (7.2 kV/160–400A)

Delay Setting	SW4	SW5	SW6
30 ms	Off	Off	Off
50 ms	On	Off	Off
130 ms	Off	On	Off
250 ms	On	On	Off
330 ms	Off	Off	On

#### Altitude Designations (7.2 kV/160–400A)

Altitude	Low	Standard	High
Feet	–11,483 to –3281	–3281 to +6562	+6562 to +13,123
Meters	–3500 to –1000	–1000 to +2000	+2000 to +4000

##### Note

Stock units pre-set to 120/60 Vac.

**SL Series Fuses****Fuse Application Table for SL Contactors—7.2 kV/160A**

Motor FLA	Voltage	Suggested Eaton Fuse	Rating	Minimum Opening Time
11–18	2400–4800	5BCLS-30	30–1R	30
18–31	2400–4800	5BCLS-2R	70–2R	30
31–46	2400–4800	5BCLS-3R	100–3R	30
46–62	2400–4800	5BCLS-4R	130–4R	30
62–74	2400–4800	5BCLS-5R	150–5R	30
74–93	2400–4800	5BCLS-6R	170–6R	30
93–137	2400–4800	5BCLS-9R	200–9R	130
137–160	2400–4800	5BCLS-12R	230–12R	130
11–34	5500–6600	7BCLS-2R	70–2R	30
34–46	5500–6600	7BCLS-3R	100–3R	30
46–56	5500–6600	7BCLS-4R	130–4R	30
56–68	5500–6600	7BCLS-5R	150–5R	30
68–85	5500–6600	7BCLS-6R	170–6R	30
85–137	5500–6600	7BCLS-9R	200–9R	50
137–160	5500–6600	7BCLS-12R	230–12R	250
137–160	5500–6600	7BCLS-12R	230–12R	250

**Fuse Application Table for SL Contactors—7.2 kV/260A**

Motor FLA	Voltage	Suggested Eaton Fuse	Rating	Minimum Opening Time
11–18	2400–4800	5BCLS-30	30–1R	30
18–31	2400–4800	5BCLS-2R	70–2R	30
31–46	2400–4800	5BCLS-3R	100–3R	30
46–62	2400–4800	5BCLS-4R	130–4R	30
62–74	2400–4800	5BCLS-5R	150–5R	30
74–93	2400–4800	5BCLS-6R	170–6R	30
93–137	2400–4800	5BCLS-9R	200–9R	130
137–200 <sup>①</sup>	2400–4800	5BCLS-12R	230–12R	130
11–34	5500–6600	7BCLS-2R	70–2R	30
34–46	5500–6600	7BCLS-3R	100–3R	30
46–56	5500–6600	7BCLS-4R	130–4R	30
56–68	5500–6600	7BCLS-5R	150–5R	30
68–85	5500–6600	7BCLS-6R	170–6R	30
85–137	5500–6600	7BCLS-9R	200–9R	50
137–200 <sup>①</sup>	5500–6600	7BCLS-12R	230–12R	250

**Fuse Application Table for SL Contactors—7.2 kV/360A**

Motor FLA	Voltage	Suggested Eaton Fuse	Rating	Minimum Opening Time
11–18	2400–4800	5BCLS-30	30–1R	30
18–31	2400–4800	5BCLS-2R	70–2R	30
31–46	2400–4800	5BCLS-3R	100–3R	30
46–62	2400–4800	5BCLS-4R	130–4R	30
62–74	2400–4800	5BCLS-5R	150–5R	30
74–93	2400–4800	5BCLS-6R	170–6R	30
93–137	2400–4800	5BCLS-9R	200–9R	130
137–187	2400–4800	5BCLS-12R	230–12R	130
187–200	2400–4800	5BCLS-12R	230–12R	130
200–360	2400–4800	N/A	—	—
11–34	5500–6600	7BCLS-2R	70–2R	30
34–46	5500–6600	7BCLS-3R	100–3R	30
46–56	5500–6600	7BCLS-4R	130–4R	30
56–68	5500–6600	7BCLS-5R	150–5R	30
68–85	5500–6600	7BCLS-6R	170–6R	30
85–137	5500–6600	7BCLS-9R	200–9R	50
137–200	5500–6600	7BCLS-12R	230–12R	250
187–200	5500–6600	7BCLS-12R	230–12R	250
200–360	5500–6600	N/A	—	—

**Fuse Application Table for SL Contactors—7.2 kV/400A**

Motor FLA	Voltage	Suggested Eaton Fuse	Rating	Minimum Opening Time
11–18	2400–4800	5BCLS-30	30–1R	30
18–31	2400–4800	5BCLS-2R	70–2R	30
31–46	2400–4800	5BCLS-3R	100–3R	30
46–62	2400–4800	5BCLS-4R	130–4R	30
62–74	2400–4800	5BCLS-5R	150–5R	30
74–93	2400–4800	5BCLS-6R	170–6R	30
93–137	2400–4800	5BCLS-9R	200–9R	30
137–187	2400–4800	5BCLS-12R	230–12R	30
187–273	2400–4800	5BCLS-18R	390–18R	50
273–400 <sup>②</sup>	2400–4800	5BCLS-24R	450–24R	130
11–34	5500–6600	7BCLS-2R	70–2R	30
34–46	5500–6600	7BCLS-3R	100–3R	30
46–56	5500–6600	7BCLS-4R	130–4R	30
56–68	5500–6600	7BCLS-5R	150–5R	30
68–85	5500–6600	7BCLS-6R	170–6R	30
85–137	5500–6600	7BCLS-9R	200–9R	30
137–187	5500–6600	7BCLS-12R	230–12R	30
187–273	5500–6600	7BCLS-18R	390–18R	50
273–400 <sup>②</sup>	5500–6600	7BCLS-24R	450–24R	250

**Notes**

<sup>①</sup> For FLA > 180, maximum acceleration time = 4.5 seconds.

<sup>②</sup> For FLA > 360, maximum acceleration time = 6 seconds.

Fuse selections based on LRC = FLA x 6 with acceleration time of 10 seconds except where otherwise noted.

**SL Series Ratings****Type SL Vacuum Contactor Ratings (7.2 kV/160–400A)**

Rated Utilization Voltage	Interrupting Rating		Application Table					Maximum Insulation Voltage
	NEMA Unfused (E1) kA	NEMA Fused (E2) kA	Induction Motor Horsepower	Synchronous Motor Horsepower (0.8 PF) (1.0 PF)		Transformer kVA	Capacitor kVAR	
<b>7.2 kV/160A Frame</b>								
2200–2500	4.5	50	600	600	800	600	480	7200
3000–3600	4.5	50	900	900	1000	800	640	7200
3800–4800	4.5	50	1200	1200	1400	1000	960	7200
6000–6900	4.5	50	1800	1800	2200	1600	1320	7200
<b>7.2 kV/200A Frame</b>								
2200–2500	4.5	50	800	800	1000	750	600	7200
3000–3600	4.5	50	1100	1100	1250	1000	800	7200
3800–4800	4.5	50	1500	1500	1750	1250	1200	7200
6000–6900	4.5	50	2250	2250	2750	2000	1650	7200
<b>7.2 kV/360A Frame</b>								
2200–2500	4.5	50	1500	1500	1750	1200	1000	7200
3000–3600	4.5	50	2000	2000	2500	1600	1475	7200
3800–4800	4.5	50	2500	2500	3000	2000	2150	7200
6000–6900	4.5	50	4000	4000	5000	3200	2950	7200
<b>7.2 kV/400A Frame</b>								
2200–2500	8.5	50	1750	1750	2000	1500	1200	7200
3000–3600	8.5	50	2250	2250	2500	2000	1650	7200
3800–4800	8.5	50	3000	3000	3500	2500	2400	7200
6000–6900	8.5	50	4500	4500	5500	4000	3300	7200

**Rating Specifications (7.2 kV/160–400A)**

Ampere Rating	7.2 kV/160A	7.2 kV/200A	7.2 kV/360A	7.2 kV/400A
<b>Maximum Interrupting Current</b> (Three operations—amperes)	4500	4500	4500	8500
<b>Rated Current</b>	160	200	360	400
<b>IEC Make-Break Capability—AC4 (Amperes)</b>				
Make	1600	2000	3600	4000
Break	1280	1600	2880	3200

**Product Specifications**

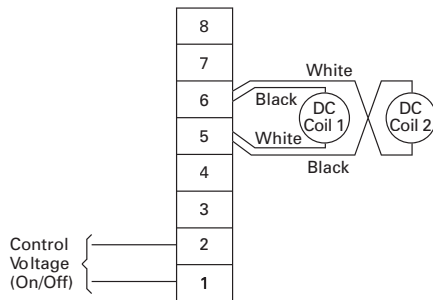
**7.2 kV/160–400A**

- Short-time current:
  - 30 seconds: 2400A
  - 1 second: 6000A
  - 8.7 ms: 63 kA peak (0.5 cycle)
- Normal service altitude: –3281 to +6562 ft (–1000 to +2000m)
- Mechanical life: 2.5 million
- Electrical life:
  - 6 x Rated Make/1x Rated Break: 300,000 operations
  - 6 x Rated Make/6 x Rated Break: 300,000 operations
- BIL (impulse withstand): 60 kV (1.2 x 50 microseconds)
- Dielectric strength: 20 kV rms (1 minute)
- Closing time: 80 milliseconds (energization to contact touch)
- Selectable opening times:
  - 30 milliseconds (2 cycles)
  - 50 milliseconds (3 cycles)
  - 130 milliseconds (8 cycles)
  - 250 milliseconds (15 cycles)
  - 330 milliseconds (20 cycles)
- Arcing time: 12 ms (0.75 cycle) or less
- Pickup voltage: 80% rated coil voltage
- Dropout voltage: 60% rated coil voltage
- Control voltages:
  - AC/Hz: 110/50, 120/60, 220/50, 240/60
  - DC: 125
- Control circuit burden:
  - Closing: (200 milliseconds)
    - 110/120 AC, 125 DC 1 kVA
    - 220/240 AC 1.8 kVA
  - Holding:
    - 110/120 AC, 125 DC 40 VA
    - 220/240 AC 50 VA
- Auxiliary contact rating:
  - 600V (maximum)
  - 10A continuous current
  - Making capacity
    - AC: 7200 VA
    - DC: 125 VA
  - Breaking capacity
    - AC: 720 VA
    - DC: 125 VA
- Latch (when specified)
  - Mechanical life: 250,000 operations
  - Trip voltage
    - DC: 24V
    - DC: 125V
    - AC: 110/120V
  - Minimum trip voltage: 80% rated coil voltage
  - Trip burden
    - 24 Vdc: 400 VA
    - 48 and 125 Vdc: 400 VA
    - 110 and 120 Vac: 400 VA
    - 220 and 240 Vac: 400 VA
  - Trip time (2 cycles): 30 ms
- Weight
  - 150–360A: 47 lbs (21.3 kg)
  - 400A: 49 lbs (22.2 kg)

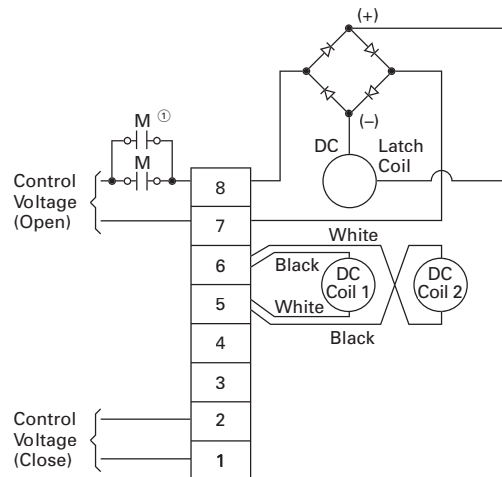
**Wiring Diagrams**

**Electrical Connections Diagrams (7.2 kV/160–400A)**

**Connection for Magnetically Held Contactor**



**Connections for Mechanically Latched Contactor**



**Note**

① M contacts are connected in parallel for ≤ 48V. M contacts are connected in series for > 48V.



# 26.2

## Power Breakers, Contactors and Fuses

### Medium Voltage Power Contactors

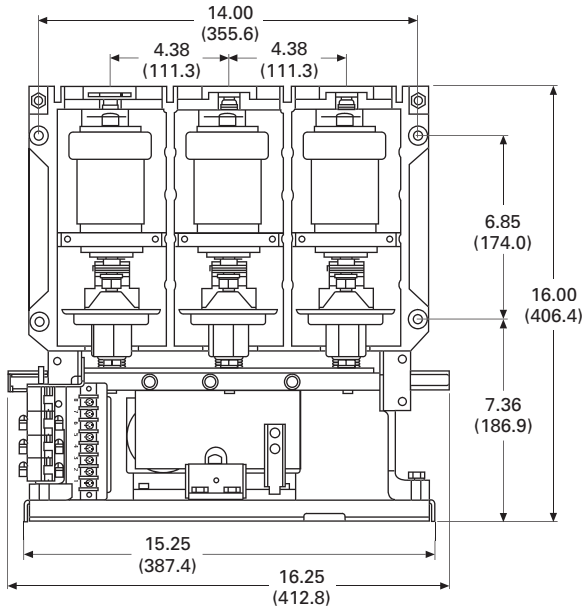
#### Dimensions

Approximate Dimensions in Inches (mm)

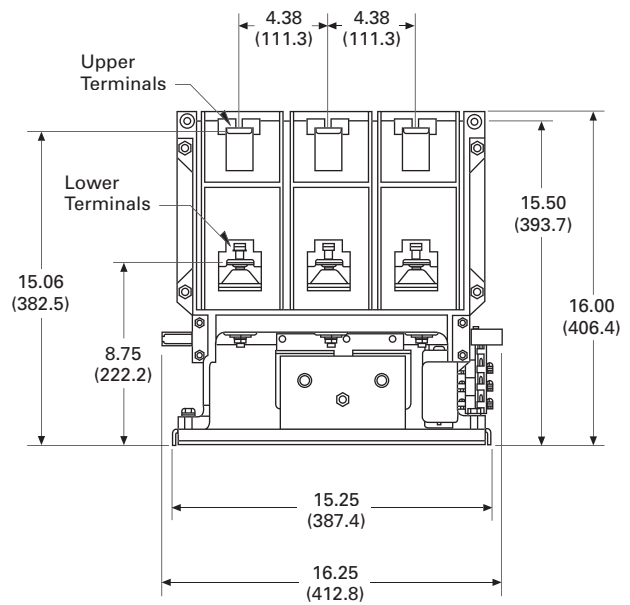
#### Dimensional Drawings 7.2 kV/160-400A

26

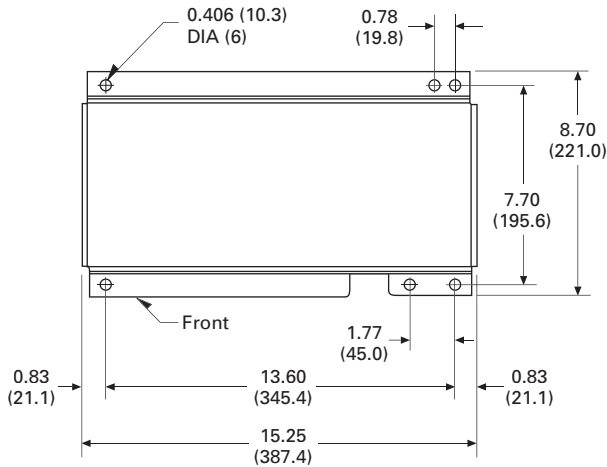
#### Front



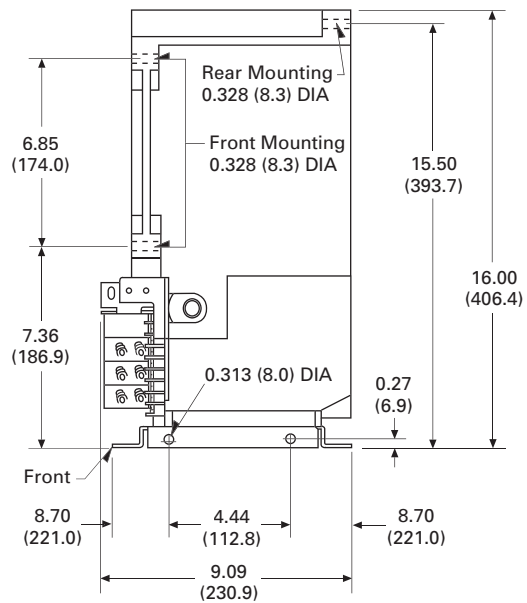
#### Rear



#### Base Plate

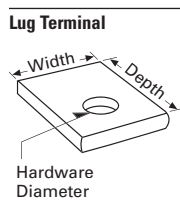
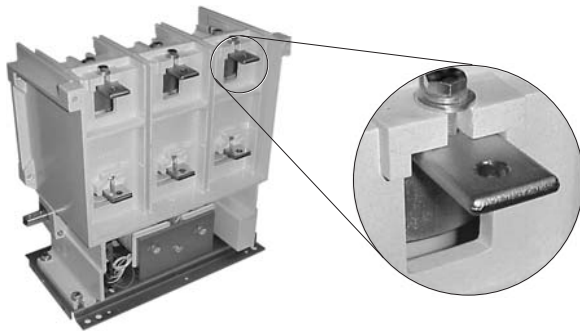


#### Side



Approximate Dimensions in Inches (mm)

**Lug Terminal**



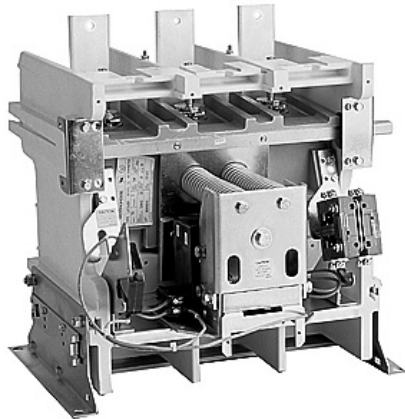
**Upper Lug Terminal**

Contactor Ampere Rating	Width	Depth	Hardware (Bolt Diameter)
7.2 kV/160	0.75 (19.1)	1.31 (33.3)	10
7.2 kV/200	1.00 (25.4)	1.31 (33.3)	10
7.2 kV/360	1.00 (25.4)	1.31 (33.3)	10
7.2 kV/400	1.00 (25.4)	1.31 (33.3)	10

**Lower Lug Terminal**

Contactor Ampere Rating	Width	Depth	Hardware (Bolt Diameter)
7.2 kV/160	1.25 (31.8)	1.10 (27.9)	10
7.2 kV/200	1.25 (31.8)	1.10 (27.9)	10
7.2 kV/360	1.25 (31.8)	1.10 (27.9)	10
7.2 kV/400	1.25 (31.8)	1.10 (27.9)	10

SL 7.2 kV/800A Medium Voltage Contactor



### Contents

<i>Description</i>	<i>Page</i>
Product Overview . . . . .	<b>V4-T26-51</b>
SL MV Power Contactor 7.2 kV/160–400A . . . . .	<b>V4-T26-53</b>
SL MV Power Contactor 7.2 kV/800A	
Options and Accessories . . . . .	<b>V4-T26-63</b>
Technical Data and Specifications . . . . .	<b>V4-T26-63</b>
Dimensions . . . . .	<b>V4-T26-65</b>
SL MV Power Contactor 15 kV/250A . . . . .	<b>V4-T26-66</b>

### SL MV Power Contactor 7.2 kV/800A

#### Product Description

- A single family of contactors for any medium voltage control application. Voltage range of 2200–7200V
- 800A rating with induction motor horsepower ranges from 3000–10,000 hp

#### Application Description

##### *Eaton's SL Medium Voltage Contactors starting applications:*

- Squirrel-cage induction motors
- Synchronous motors
- Wound-rotor

##### *Fully applicable to:*

- Full voltage starting
- Reduced voltage starting

##### *The perfect choice for harsh duty applications:*

- Mining
- Pulp and paper
- HVAC
- Petrochemical
- Automotive
- Many others

#### Features, Benefits and Functions

- Two different altitude versions
- Leading-edge vacuum technology
- Long life—100,000 electrical and 300,000 mechanical
- Special ordering allows unit to be factory pre-set to customer specification, including field kit installation
- Highest quality available—all contactors manufactured within state-of-the-art "ISO-Certified" facilities. 100% made in America

##### *Factory Installed Option Kit*

- Mechanical latch—many coil voltages

##### *Long Life Guarantees High Quality*

- 100,000 electrical operations
- 300,000 mechanical operations

#### Standards and Certifications

##### *Acceptability*

- NEMA
- ANSI
- IEC

##### *Third-Party Verification*

- UL
- CSA
- KEMA

##### *Design and Test Standards*

- UL 347, File No. E63257
- CSA T.I.L. D-21, File No. LR28548
- ANSI/NEMA ICS 3
- IEC 60470

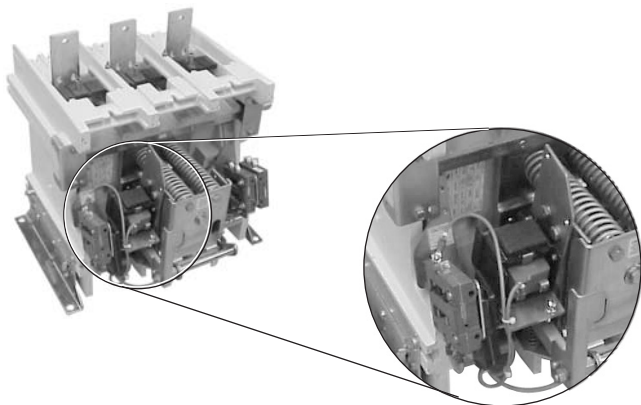


#### Product Selection

Contact Eaton for pricing.

**Options and Accessories**

**SL Series—Accessory Options 800A**



*Mechanical Latch Assembly 800A*

**Mechanical Latch Option—  
SL Vacuum Contactor  
Size 800A**

Factory installed for 800A SL Vacuum Contactor. Coil voltages available in a wide range of AC and DC selections.

**Technical Data and Specifications**

**The SL Contactor Ratings**

- Voltages of 2200–7200V
- 800A (720A enclosed)
- Interrupting rating of 12,500A

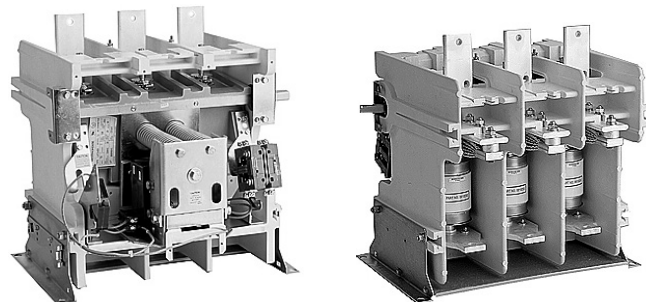
**Control Voltages**

- 110, 220 Vac, 50 Hz
- 120, 240 Vac, 60 Hz
- 125 Vdc

**Dropout Time**

- 130–330 ms

**Front and Rear View 7.2 kV/800A**



*Front View*

*Rear View*

**SL Series Fuses**

**Fuse Application Table for SL Contactors 7.2 kV/SL-800**

Motor FLA	Voltage	Suggested Eaton Fuse	Rating	Minimum Opening Time
225–360	2400–4800	5BCLS-24R	450–24R	50
360–449	2400–4800	5BCLS-36R	650–36R	130
450–720	2400–4800	5BCLS-44R	800–44R	250
225–400	5500–6600	7BCLS-24R	450–24R	50
400–449	5500–6600	7BCLS-36R	650–36R	130
450–720	5500–6600	7BCLS-44R	800–44R	250

**Note**

Fuse selections based on LRC = FLA x 6 with acceleration time of 10 seconds except where otherwise noted.

#### SL Series Ratings

#### Type SL Vacuum Contactor Ratings 7.2 kV/SL-800

26

Rated Utilization Voltage	Interrupting Rating		Application Table					
	NEMA Unfused (E1) kA	NEMA Fused (E2) kA	Induction Motor Horsepower	Synchronous Motor Horsepower (0.8 PF) (1.0 PF)		Transformer kVA	Capacitor kVAR	Maximum Insulation Voltage
2200–2500	12.5 (50 MVA)	50 (200 MVA at 2300V)	3000	3000	3500	2500	2400	7200
3000–3600	12.5 (50 MVA)	50 (285 MVA at 3300V)	4000	4000	5000	3500	3200	7200
3800–5000	12.5 (75 MVA)	50 (400 MVA at 4600V)	5000	5000	6000	4500	4000	7200
6000–7200	12.5 (100 MVA)	50 (570 MVA at 6600V)	8000	8000	10,000	6000	4800	7200

#### Rating Specifications 7.2 kV/SL-800

Ampere Rating	7.2 kV/800A
Maximum Interrupting Current (Three operations—amperes)	12,500
Rated Current	800 (720 enclosed)
IEC Make-Break Capability—AC4 (Amperes)	
Make	8000
Break	6400

#### Product Specifications

##### 7.2 kV/800A

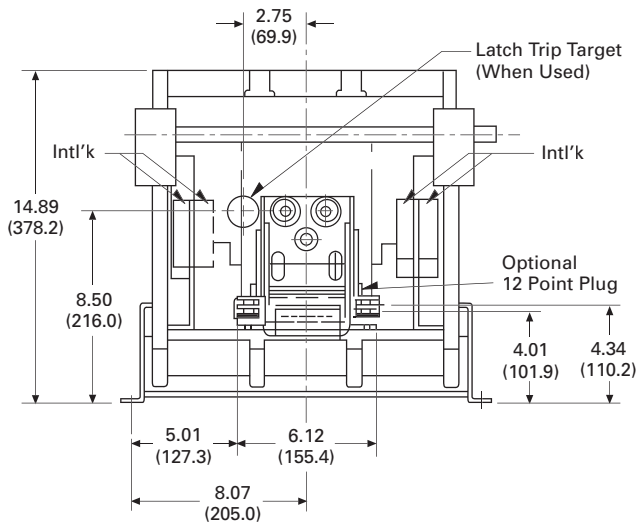
- Short-time current
  - 30 seconds: 4320A
  - 1 second: 10,800A
  - 8.7 ms (0.5 cycle) 86 kA peak
- Normal service altitude: –3281 to +6562 ft (–1000 to +2000m)
- Mechanical life: 1 million
- Electrical life: 100,000 operations
- BIL (impulse withstand): 60 kV (1.2 x 50 microseconds)
- Dielectric strength: 18.2 kV rms (1 minute)
- Closing time (energization to contact touch): 80 milliseconds
- Opening times (de-energization to full open):
  - 130 ms (8 cycles)
  - 200 ms (12 cycles)
  - 330 ms (20 cycles)
- Arcing time: 12 ms (0.75 cycle) or less
- Pickup voltage: 80% rated coil voltage
- Dropout voltage: 60% rated coil voltage
- Control voltages:
  - AC/Hz: 110/50, 120/60 Vac, 220/50, 240/60
  - DC: 125 Vdc
- Control circuit burden:
  - Closing (120/240): 2600 VA
  - Holding (120/240): 50 VA
- Auxiliary contact rating:
  - 600V (maximum)
  - 10A continuous current
- Making capacity
  - AC: 7200 VA
  - DC: 200 VA
- Breaking capacity
  - AC: 720 VA
  - DC: 200 VA
- Latch (when specified):
  - Mechanical life: 250,000 operations
  - Trip voltage
    - DC: 24, 48, 96V
    - AC: 110/120, 220/240V 50/60 Hz
  - Minimum trip voltage: 80% rated coil voltage
  - Trip burden
    - 24 Vdc: 1200 VA
    - 48 and 96 Vdc: 400 VA
    - 110 and 220 Vac: 500 VA
  - Trip time (2 cycles): 30 milliseconds
- Weight: 95 lbs (43.1 kg)

**Dimensions**

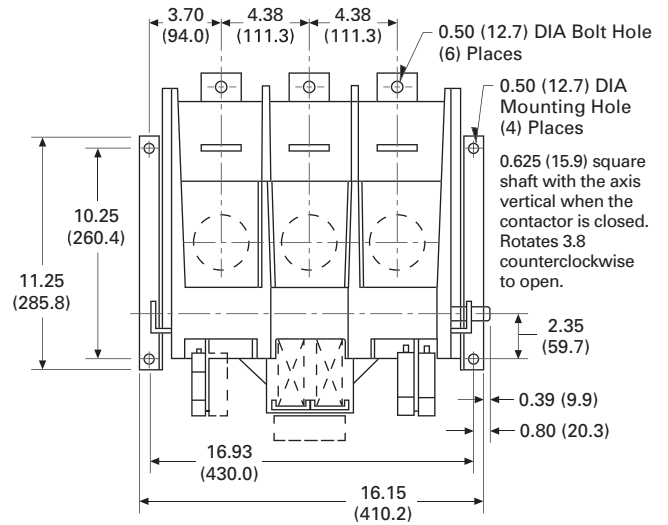
Approximate Dimensions in Inches (mm)

**Dimensional Drawings 7.2 kV/800A**

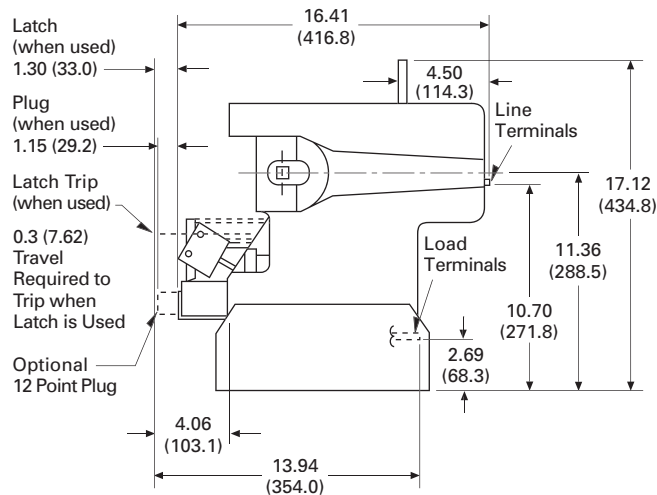
**Side**



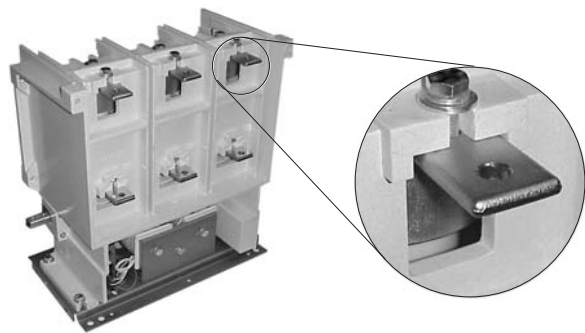
**Top**



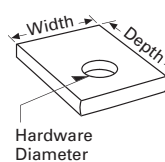
**Front**



**Lug Terminal**



**Lug Terminal**



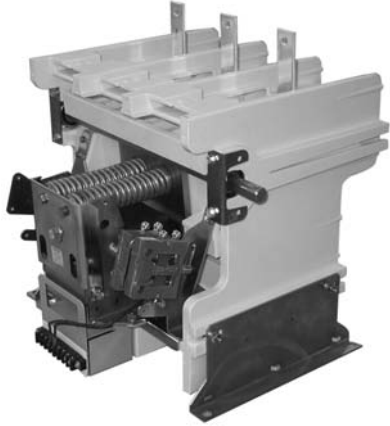
**Upper Lug Terminal**

Contactor Ampere Rating	Width	Depth	Hardware (Bolt Diameter)
7.2 kV/800	1.75 (44.5)	2.00 (50.8)	10

**Lower Lug Terminal**

Contactor Ampere Rating	Width	Depth	Hardware (Bolt Diameter)
7.2 kV/800	1.50 (38.1)	1.50 (38.1)	10

SL 15 kV/250A Medium Voltage Contactor



26

### Contents

<i>Description</i>	<i>Page</i>
Product Overview . . . . .	<b>V4-T26-51</b>
SL MV Power Contactor 7.2 kV/160–400A . . . . .	<b>V4-T26-53</b>
SL MV Power Contactor 7.2 kV/800A . . . . .	<b>V4-T26-62</b>
SL MV Power Contactor 15 kV/250A	
Options and Accessories . . . . .	<b>V4-T26-67</b>
Technical Data and Specifications . . . . .	<b>V4-T26-67</b>
Dimensions . . . . .	<b>V4-T26-69</b>

### SL MV Power Contactor 15 kV/250A

#### Product Description

- A single family of contactors for any medium voltage control application. Voltage range of 7200–15,000V
- 250A rating with induction motor horsepower ranges from 500–5000 hp
- Two different altitude versions
- Leading-edge vacuum technology
- Long life—250,000 electrical and mechanical operations
- Special ordering allows unit to be factory pre-set to customer specification, including field kit installation
- Highest quality available—all contactors manufactured within state-of-the-art “ISO-Certified” facilities. 100% made in America

#### Application Description

##### *Eaton’s SL Medium Voltage Contactors starting applications:*

- Squirrel-cage induction motors
- Synchronous motors
- Wound-rotor

##### *Fully applicable to:*

- Full voltage starting
- Reduced voltage starting

##### *The perfect choice for harsh duty applications:*

- Mining
- Pulp and paper
- HVAC
- Petrochemical
- Automotive
- Many others

#### Features, Benefits and Functions

##### *Factory Installed Option Kit*

- Mechanical latch—many coil voltages

##### *Long Life Guarantees High Quality*

- 250,000 electrical operations
- 250,000 mechanical operations

#### Standards and Certifications

##### *Acceptability*

- NEMA
- ANSI
- IEC

##### *Third-Party Verification*

- UL
- CSA
- KEMA

##### *Design and Test Standards*

- UL 347, File No. E63257
- CSA T.I.L. D-21, File No. LR28548
- ANSI/NEMA ICS 3
- IEC 60470

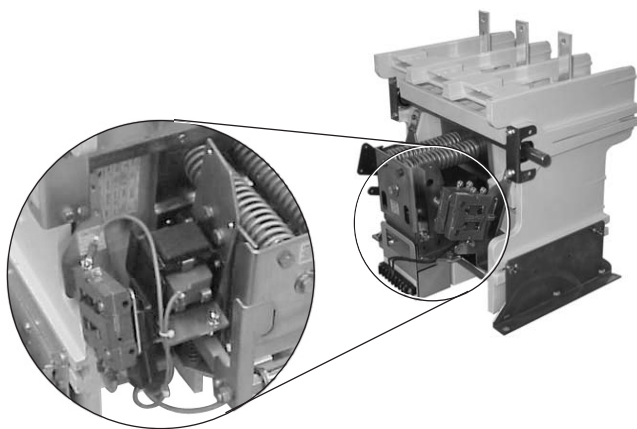


#### Product Selection

Contact Eaton for pricing.

**Options and Accessories**

**SL Series—Accessory Options 15 kV/250A**



*Mechanical Latch Assembly 15 kV/250A*

**Mechanical Latch Option—  
SL Vacuum Contactor**

Factory installed for 15 kV/250A SL Vacuum Contactor. Coil voltages available in a wide range of AC and DC selections.

**Technical Data and Specifications**

**The SL Contactor Ratings**

- Voltages to 15,000V
- 250A
- Interrupting rating of 5000A

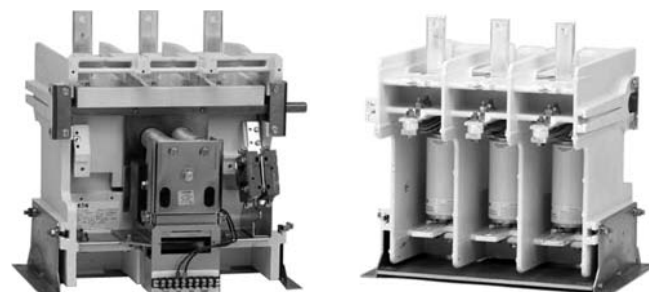
**Control Voltages**

- 110, 220 Vac, 50 Hz
- 120, 240 Vac, 60 Hz
- 125 Vdc

**Dropout Time**

- 50–330 ms
- Field selectable

**Front and Rear View 15 kV/250A**



*Front View*

*Rear View*

**SL Series Fuses**

**Fuse Application Table for SL Contactors 15 kV/SL-250A**

Motor FLA	Voltage	Suggested Eaton Fuse	Rating	Minimum Opening Time
50–200 ①	10,000–13,800	15HLE-250E	250E	130

**Notes**

① For FLA > 150, contact factory for maximum acceleration time.  
Fuse selections based on LRC = FLA x 6 with acceleration time of 10 seconds except where otherwise noted.



#### SL Series Ratings

#### Type SL Vacuum Contactor Ratings 15 kV/250A

26

Rated Utilization Voltage	Interrupting Rating		Application Table					
	NEMA Unfused (E1) kA	NEMA Fused (E2) kA	Induction Motor Horsepower	Synchronous Motor Horsepower		Transformer kVA	Capacitor kVAR	Maximum Insulation Voltage
				(0.8 PF)	(1.0 PF)			
10,000–11,000	5	50 (950 MVA at 11,000V)	4000	4000	4500	3800	Consult factory	15,000
12,400–13,800	5	50 (1190 MVA at 13,800V)	5000	5000	5500	4750	Consult factory	15,000

#### Rating Specifications 15 kV/250A

Ampere Rating	15 kV/250A
<b>Maximum Interrupting Current</b> (Three operations—amperes)	5000
<b>Rated Current</b>	250
<b>IEC Make-Break Capability—AC4 (Amperes)</b>	
Make	2500
Break	2000

#### Product Specifications

##### 15kV/250A

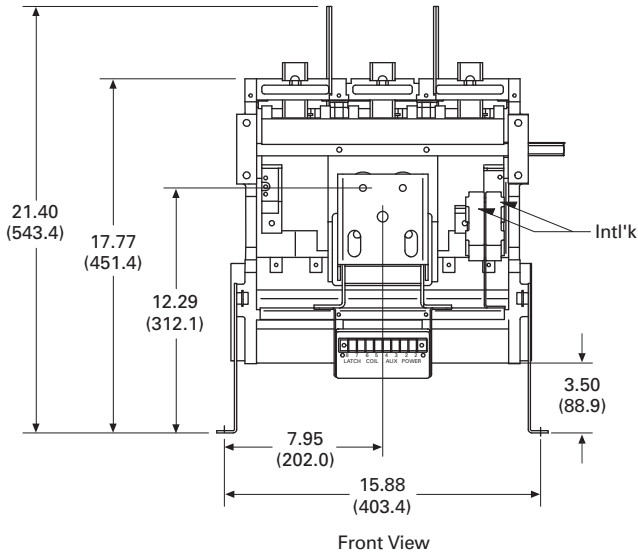
- Short-time current
  - 30 seconds: 1500A
  - 1 second: 3750A
  - 8.7 ms (0.5 cycle) 25 kA peak
- Normal service altitude: –3281 to +6562 ft (–1000 to +2000m)
- Mechanical life: 250,000 operations
- Electrical life: 250,000 operations
- BIL (impulse withstand): 75 kV (1.2 x 50 microseconds)
- Dielectric strength: 36 kV rms (1 minute)
- Closing time (energization to contact touch): 80 milliseconds
- Selectable opening times (de-energization to full open):
  - 50 ms (3 cycles)
  - 130 ms (8 cycles)
  - 250 ms (12 cycles)
  - 330 ms (20 cycles)
- Arcing time: 12 ms (0.75 cycle) or less
- Pickup voltage: 80% rated coil voltage
- Dropout voltage: 60% rated coil voltage
- Control voltages:
  - AC/Hz: 110/50, 120/60 Vac, 220/50, 240/60
  - DC: 125 Vdc
- Control circuit burden:
  - Closing (120/240): 1700/2600 VA
  - Holding (120/240): 80 VA
- Auxiliary contact rating:
  - 600V (maximum)
  - 10A continuous current
- Making capacity
  - AC: 7200 VA
  - DC: 200 VA
- Breaking capacity
  - AC: 720 VA
  - DC: 200 VA
- Latch (when specified):
  - Mechanical life: 250,000 operations
  - Trip voltage
    - DC: 24, 48, 96V
    - AC: 110/120, 220/240V, 50/60 Hz
  - Minimum trip voltage: 80% rated coil voltage
  - Trip burden
    - 24 Vdc: 1200 VA
    - 48 and 96 Vdc: 400 VA
    - 110 and 220 Vac: 500 VA
  - Trip time (2 cycles): 30 milliseconds
- Weight: 95 lbs (43.1 kg)

**Dimensions**

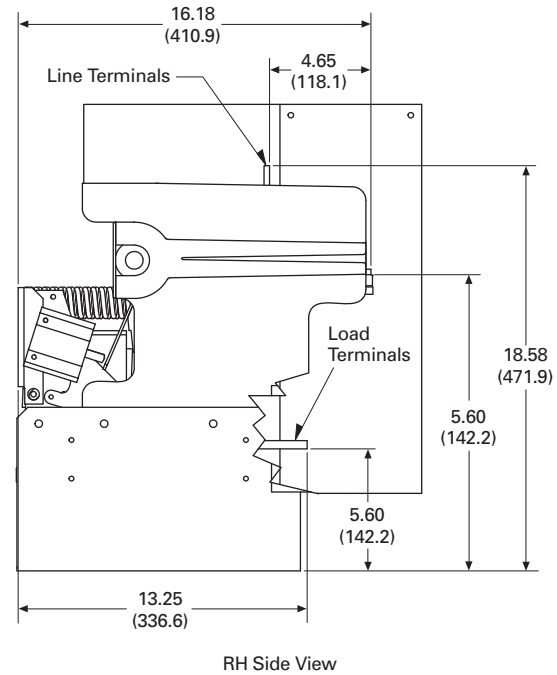
Approximate Dimensions in Inches (mm)

**Dimensional Drawings 15 kV/250A**

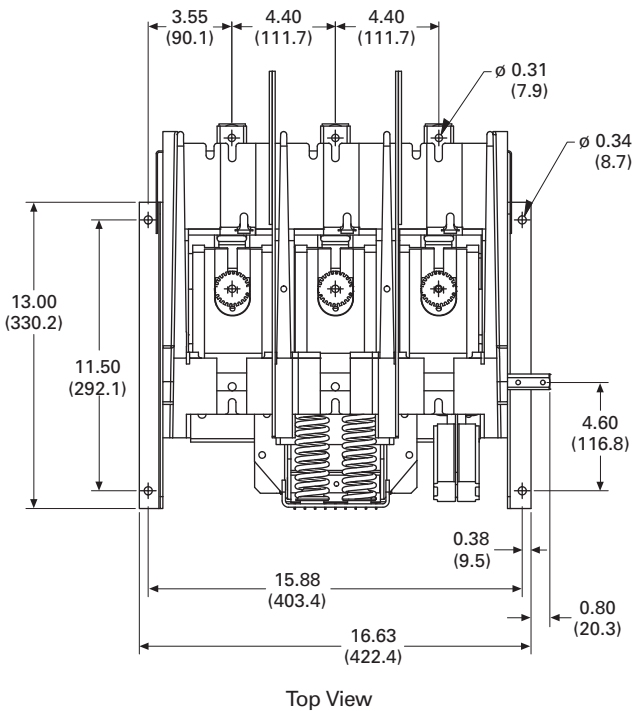
**Front**



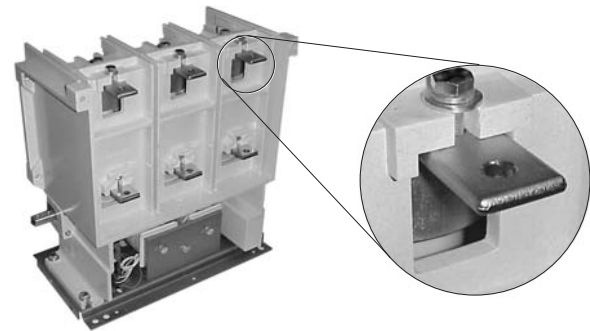
**Side 15 kV/250A**



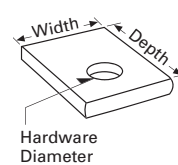
**Top**



**Lug Terminal**



**Lug Terminal**



**Upper Lug Terminal**

Contactor Ampere Rating	Width	Depth	Hardware (Bolt Diameter)
15 kV/250	1.25 (31.8)	1.25 (31.8)	10

**Lower Lug Terminal**

Contactor Ampere Rating	Width	Depth	Hardware (Bolt Diameter)
15 kV/250	1.50 (38.1)	1.25 (38.1)	10

**Contents****Description**

Fuses General

**Product Overview****Power Fuse**

Eaton's roots in the medium voltage power fuse business began over 75 years ago under Westinghouse® Electric. In 1935, Westinghouse introduced the medium voltage boric acid expulsion fuse followed by the medium voltage current limiting fuse. Even today, medium voltage fuses continue to use that core technology. Eaton continues to build on the technology legacy by engineering higher performance, cost-effective power fuse products.

Eaton's medium voltage fuses are manufactured and tested to the requirements of the C37-4X series of standards, which are maintained and updated regularly to maintain currency with industry practices. These standards are:

**IEEE Std. C37.40™**

IEEE Standard Service Conditions and Definitions for High Voltage Fuses, Distribution Enclosed Single-Pole Air Switches, Fuse Disconnecting Switches, and Accessories (ANSI).

**IEEE Std. C37.41™**

IEEE Standard Design Tests for High-Voltage (>1000V) Fuses, Fuse and Disconnecting Cutouts, Distribution Enclosed Single-Pole Air Switches, Fuse Disconnecting Switches, and Fuse Links and Accessories used with These Devices (ANSI).

**ANSI C37.42™**

IEEE Standard Specifications for High-Voltage (>1000V) Expulsion-Type Distribution-Class Fuses, Fuse and Disconnecting Cutouts, Fuse Disconnecting Switches, and Fuse Links, and Accessories used with These Devices (ANSI).

**ANSI C37.46**

American National Standard for High Voltage Expulsion and Current Limiting Type Power Class Fuses and Fuse Disconnecting Switches.

**ANSI C37.47**

American National Standard for High Voltage Current Limiting Type Distribution Class Fuses and Fuse Disconnecting Switches.

The following IEEE standards are also applicable to the fuse products covered in this publication:

**IEEE Std. C37.48™**

IEEE Guide for the Application, Operation, and Maintenance of High Voltage Fuses, Distribution Enclosed Single-Pole Air Switches, Fuse Disconnecting Switches, and Accessories (ANSI).

**IEEE Std. C37.48.1™**

IEEE Guide for the Classification, Application, and Coordination of Current-Limiting Fuses with Rated Voltages 1–38 kV.

A better understanding of some fuse terminology will help you understand and select the correct fuse. The following is a brief overview of those terms.

**Power vs. Distribution**

The differentiation is intended to indicate the test conditions and where fuses are normally applied on an electrical system, based on specific requirements for generating sources, substations and distribution lines. Each class has its own unique set of voltage, current and construction requirements (see C37.42, .46 and .47).

**Low vs. Medium vs. High Voltage**

While fuses are defined in the ANSI standards as either low or high voltage, Eaton has elected to name their fuses to correspond with the equipment in which they are installed. Therefore, per ANSI C84, our fuses are named as follows:

- Low voltage—1000V and below
- Medium voltage—greater than 1000 to 69,000V
- High voltage—greater than 69,000V

**Expulsion vs. Current Limiting (Definitions per ANSI C47.40-1993)**

An expulsion fuse is a vented fuse in which the expulsion effect of the gases produced by internal arcing, either alone or aided by other mechanisms, results in current interruption.

An expulsion fuse is not current limiting and as a result limits the duration of a fault on the electrical system, not the magnitude.

A current limiting fuse is a fuse that, when its current responsive element is melted by a current within the fuse's specified current limiting range, abruptly introduces a high resistance to reduce current magnitude and duration, resulting in subsequent current interruption. Refer to Fuse Types Protection Range figure on **Page V4-T26-72** for a features comparison.

**Fuse Types**

There are three current limiting fuse types: Backup, General Purpose and Full Range. It is important that the user have an understanding of these definitions to ensure proper application of the fuse (see Fuse Types Protection Range figure on **Page V4-T26-72**).

**Backup Fuses**

A fuse capable of interrupting all currents from the maximum rated interrupting current down to the rated minimum interrupting current.

Backup fuses are always used in a series with another interrupting device capable of interrupting currents below the fuse's minimum interrupting current.

**General Purpose Fuses**

A fuse capable of interrupting all currents from the rated interrupting current down to the current that causes melting of the fusible element in no less than one hour.

General Purpose fuses are typically used to protect feeders and components such as transformers.

**Full Range Fuses**

A fuse capable of interrupting all currents from the rated interrupting current down to the minimum continuous current that causes melting of the fusible element, with the fuse applied at the maximum ambient temperature specified by the manufacturer.

**General Fuse Component Terms****Fuse Refill Unit (of an Expulsion Fuse)**

A fuse refill unit is a replaceable assembly containing the calibrated current-responsive fuse element and certain other items that facilitate current interruption. On its own, the refill unit has no interrupting ability. A refill unit must be mounted in a fuseholder with a spring assembly to form a refillable fuse unit. The refill unit is the section of the fuse that must be replaced after a fuse operation.

**Fuseholder (of an Expulsion Fuse)**

A fuseholder is a reusable holder that when equipped with a fuse refill unit forms a fuse unit, capable of interrupting an overload or fault current. A fuseholder is supplied with a spring and shunt assembly, necessary to complete the internal interrupting assembly. The spring and shunt assembly is supplied with the fuseholder but is also available as a replacement part, as it may need replacement after several of heavy operations.

**Fuse Unit**

A fuse unit is a replaceable unit or assembly that is able, on its own, to perform current interruption. In the case of a refillable fuse unit, the refill unit must be replaced after a fuse operation. Where a complete fuse unit is supplied from the factory, the complete fuse unit must be replaced after a fuse operation. All current-limiting fuses are fuse units.

**Exhaust Control Device**

When expulsion fuses are used in enclosures, exhaust control devices (filters, condensers or mufflers) are used to control the sound of the fuse operation, and to de-ionize and absorb the fuse exhaust products. These devices are normally supplied separately, because of different characteristics and ratings. They are reusable but may need replacement after several heavy operations.

**Mounting**

A mounting provides all the necessary parts to safely mount a fuse in its intended piece of equipment. The base is the metal support to which all other pieces attach. Insulators attach to the base and insulate the live fuse unit from the base and everything beyond the base. Live parts are the parts of the mounting that are energized once electricity is flowing. The live parts provide the means to hold the fuse unit in place, electrical contact, and a place to make line and load connections.

**Non-Disconnect Mounting**

A non-disconnect mounting does not provide a means for removing the fuse unit until the circuit is dead and the fuse unit can be removed manually. The fuse unit is held in place by friction through the use of fuse clips or by a cross bar.

#### Disconnect Mounting

The disconnect mounting allows the fuse unit to be removed (off load) using an insulated hook stick. The hookstick grabs a pull ring and disconnects the fuse unit, which may then be lifted out of its mounting.

#### Dropout Mounting

Dropout mountings are used in outdoor applications. The fuse unit is equipped with a mechanical trigger that unlatches the upper contact, allowing the fuse unit to drop out, increasing the dielectric separation, and providing visible indication of a blown fuse.

#### Live Parts

Live parts were briefly discussed as part of the "Mounting" definition. Everything above the insulators on the mounting excluding the fuse unit, fuse holder, and the fuse end fittings (if required) are considered the live parts. Fuse end fittings are discussed next and are not required with non-disconnect live parts, but are required and included with disconnect live parts. Live parts may be sold separately as replacement parts or for new OEM applications.

#### End Fittings

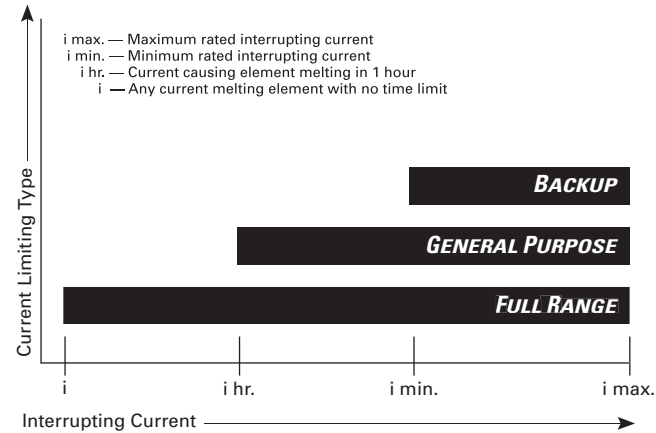
End fittings are metal parts that attach to each end of a fuse unit's ferrules (end caps). As previously mentioned, they are used solely with disconnect fuse applications or when converting a non-disconnect to a disconnect fuse configuration.

When end fittings are ordered, a fitting for each end of the fuse is included. Keep in mind that end fittings can become damaged in use and, therefore, are sold separately from the live parts when necessary. It is not necessary to purchase an entire set of live parts when only the end fittings are required.

#### General High Voltage Fuse Comparison

Expulsion	Current Limiting
Vented	Sealed
Electromechanical	Static
Interrupts at current zero	Limits fault current
Generally higher voltage and current application capabilities	Generally higher interrupting ratings
Different time/current characteristics	Different time/current characteristics

#### Fuse Types Protection Range



**Contents**

<b>Description</b>	<b>Page</b>
Catalog Number Selection . . . . .	V4-T26-74
Product Selection . . . . .	V4-T26-75

**Product Description**

Eaton’s expulsion fuses use boric acid as the interrupting medium. Under a fault condition, arc heat decomposes the boric acid into water vapor. The water vapor blast deionizes the arc path preventing arc re-ignition after a natural current zero.

Type RBA indoor expulsion fuses must be fitted with a discharge filter or condenser, that moderates the discharge exhaust. The discharge filter limits the exhaust to a small and relatively inert amount of gas and lowers the noise level without affecting the fuse interrupting rating. Steam discharge, that can effect the interrupting, is fully restricted by the condenser.

Type RDB outdoor dropout fuses include an ejector spring that forces the arcing rod through the top of the fuse. The arcing rod strikes a latch on the mounting that forces the fuse to swing outward through a 180° arc into the dropout position.

Refill units can be field installed into RBA and RDB expulsion fuses. Once the operated unit has been removed, the separately purchased unit can be easily installed into the fuse holder.

Type DBU fuse units are designed for new and aftermarket utility applications. End fittings are available, in both indoor and outdoor versions, as well as live parts and mountings. Mufflers confine the arc within the fuse and substantially reduce the noise and exhaust when the fuse interrupts.



**RBA E-Rated Refillable Boric Acid**



**RDB E-Rated Refillable Outdoor Dropout Boric Acid**



**DBU Dropout Boric Acid—for Use Indoors, Inside Switchgear or Outdoors**

**Accessories**

The following accessories are available for expulsion fuses:

**Mountings**

Mountings include a base, porcelain or glass polyester insulators, and live parts. They help enable the fuse to be safely attached to the gear. Mountings can be either disconnect, nondisconnect or dropout. Non-disconnect mountings are available in bolt-on or clamp-type arrangements. Fuses may be vertical or underhung.

**Live Parts**

Live parts attach the fuse to the insulators and are considered part of the mounting. All parts above the insulators are live parts.

**End Fittings**

End fittings are metal parts that attach to each end of the fuse at the ferrules. They are used only on disconnect fuses or when converting a nondisconnect to a disconnect fuse.

#### Catalog Number Selection

##### Expulsion Fuse

##### Easy to Use, Easy to Order!

Eaton's fuse catalog numbering system makes it easy to order the right fuse. The catalog numbers are easy to remember, unique to each fuse, and are broken down in three descriptive segments: Fuse Type, Voltage Rating and Current Rating.

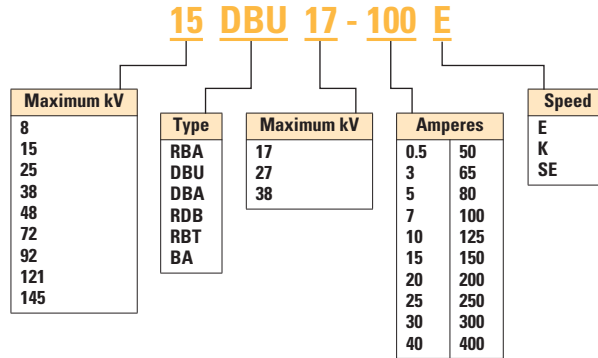
These Catalog numbers can be entered directly and easily:

- No change in order processing will occur if you use either a style number or its corresponding catalog number. You will get the same fuse
- If you are ordering a replacement for an older Westinghouse fuse, it will only have the style number. Order under this style number and you will get the correct fuse

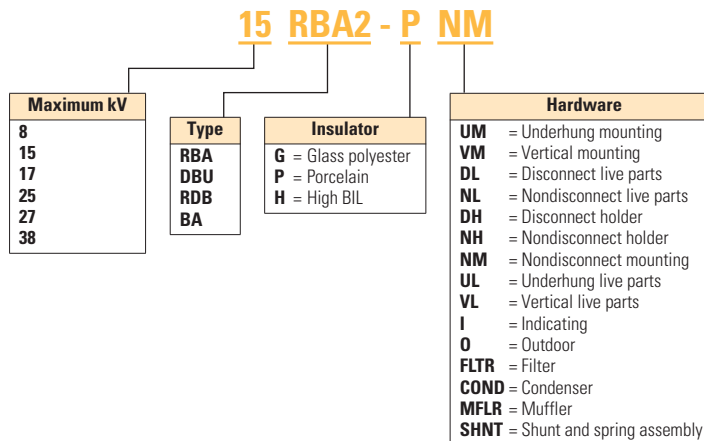
##### Examples:

8RBA2-10E	8.3 max. kV, RBA-200 refill, 10E amperes
DBU17-30K	17.1 max. kV, DBU fuse unit, 30 amperes
15RBA8-INH	15.5 max. kV, RBA-800, indicating nondisconnect holder
RBA4-FLTR	RBA-400 filter

#### Expulsion Fuse Units



#### Expulsion Fuse Accessories



## Product Selection

Contact Eaton for pricing.

### Type RBA and RDB

#### Type 8RBA2 Expulsion Fuse Refill Units—8.3 kV Maximum (7.2 kV Nominal) 200A

##### RBA/RBT Refill Units

Ampere Rating	Standard Speed (Fuse Refills)		Time Lag (Fuse Refills)		Approximate Shipping Weight Lbs (kg)
	Catalog Number	Curve Reference 36-635	Catalog Number	Curve Reference 36-635	
10E	8RBA2-10E	1, 2	—	—	1.0 (0.45)
15E	8RBA2-15E	1, 2	—	—	1.0 (0.45)
20E	8RBA2-20E	1, 2	8RBT2-20E	3, 4	1.0 (0.45)
25E	8RBA2-25E	1, 2	8RBT2-25E	3, 4	1.0 (0.45)
30E	8RBA2-30E	1, 2	8RBT2-30E	3, 4	1.0 (0.45)
40E	8RBA2-40E	1, 2	8RBT2-40E	3, 4	1.0 (0.45)
50E	8RBA2-50E	1, 2	8RBT2-50E	3, 4	1.0 (0.45)
65E	8RBA2-65E	1, 2	8RBT2-65E	3, 4	1.0 (0.45)
80E	8RBA2-80E	1, 2	8RBT2-80E	3, 4	1.0 (0.45)
100E	8RBA2-100E	1, 2	8RBT2-100E	3, 4	1.0 (0.45)
125E	8RBA2-125E	1, 2	8RBT2-125E	3, 4	1.0 (0.45)
150E	8RBA2-150E	1, 2	8RBT2-150E	3, 4	1.0 (0.45)
200E	8RBA2-200E	1, 2	8RBT2-200E	3, 4	1.0 (0.45)

#### Type RBA Expulsion Fuses for Use Indoors or in an Enclosure—8.3 kV Maximum (7.2 kV Nominal) 200A (For Use with 8RBA2 Fuseholders) ①

##### RBA Fuseholders, Mountings and Hardware (For Use with RBA/RBT Refills/holders for Indoor or Enclosure Applications)

Ampere Rating	Style	Fuseholder		Voltage (kV)		LIWL (BIL)	Mounting (Including Live Parts Less Holder)		Live Parts	Fuse Filters and Condensers	Spring and Shunt Assy.
		Non-Indicating Catalog Number	Indicating Catalog Number	Nominal	Maximum		Porcelain Insulator	Glass Polyester			
10E–200E	Non-disconnect	8RBA2-NH	8RBA2-INH	4.8	5.5	60	5RBA2-PNM	5RBA2-GNM	15RBA2-NL	RBA2-FLTR RBA2-COND	8RBA2-SHNT
	Disconnect	8RBA2-DH	BRBA2-IDH	4.8	5.5	60	5RBA2-PDM	5RBA2-GDM	14RBA2-DL	RBA2-FLTR RBA2-COND	8RBA2-SHNT
	Bolt-in	—	8RBA2-INH-B	4.8	5.5	60	5RBA8-PNM	5RBA8-GNM	15RBA8-NL	RBA2-FLTR RBA2-COND	8RBA2-SHNT

#### Type RDB Expulsion Fuses for Use Outdoors—8.3 kV Maximum (7.2 kV Nominal) 200A ②

##### RDB Fuseholders, Mountings and Hardware (For Use with RBA/RBT Refills/holders for Outdoor Applications)

Ampere Rating	Style	Fuseholder		Voltage (kV)		LIWL (BIL)	Mounting (Including Live Parts Less Holder)		Live Parts	Spring and Shunt Assy.	
		Catalog Number		Nominal	Maximum		Vertical (180°) Mounting	Underhung (90°) Mounting			
10E–200E	Dropout	8RDB2-DH		7.2	8.3	95	8RDB2-VM	8RDB2-UM	RDB2-VL	RDB2-UL	8RDB2-SHNT

#### Notes

- ① For new installation, order one refill (Standard Speed or Time Lag), one fuseholder, one mounting, and one filter or condenser per phase.  
Live parts can be substituted for the mounting if the user is supplying base support and insulators.
- ② For new installation, order one refill (Standard Speed or Time Lag), one fuseholder and one mounting per phase.  
Live parts can be substituted for the mounting if the user is supplying base support and insulators.



#### Type 8RBA4 Expulsion Fuse Refill Units—8.3 kV Maximum (7.2 kV Nominal) 400A

##### RBA/RBT Refill Units

Ampere Rating	Standard Speed (Fuse Refills)		Time Lag (Fuse Refills)		Approximate Shipping Weight Lbs (kg)
	Catalog Number	Curve Reference 36-635	Catalog Number	Curve Reference 36-635	
0.5	8RBA4-.5	5, 6	—	—	2.1 (0.95)
3	8RBA4-3	5, 6	—	—	2.1 (0.95)
5E	8RBA4-5E	5, 6	—	—	2.1 (0.95)
7E	8RBA4-7E	5, 6	—	—	2.1 (0.95)
10E	8RBA4-10E	5, 6	—	—	2.1 (0.95)
15E	8RBA4-15E	5, 6	—	—	2.1 (0.95)
20E	8RBA4-20E	5, 6	8RBT4-20E	7, 8	2.1 (0.95)
25E	8RBA4-25E	5, 6	8RBT4-25E	7, 8	2.1 (0.95)
30E	8RBA4-30E	5, 6	8RBT4-30E	7, 8	2.1 (0.95)
40E	8RBA4-40E	5, 6	8RBT4-40E	7, 8	2.1 (0.95)
50E	8RBA4-50E	5, 6	8RBT4-50E	7, 8	2.1 (0.95)
65E	8RBA4-65E	5, 6	8RBT4-65E	7, 8	2.1 (0.95)
80E	8RBA4-80E	5, 6	8RBT4-80E	7, 8	2.1 (0.95)
100E	8RBA4-100E	5, 6	8RBT4-100E	7, 8	2.1 (0.95)
125E	8RBA4-125E	5, 6	8RBT4-125E	7, 8	2.1 (0.95)
150E	8RBA4-150E	5, 6	8RBT4-150E	7, 8	2.1 (0.95)
200E	8RBA4-200E	5, 6	8RBT4-200E	7, 8	2.1 (0.95)
250E	8RBA4-250E	5, 6	8RBT4-250E	10, 11	2.1 (0.95)
300E	8RBA4-300E	5, 6	8RBT4-300E	10, 11	2.1 (0.95)
400E	8RBA4-400E	5, 6	8RBT4-400E	10, 11	2.1 (0.95)

#### Type RBA Expulsion Fuses for Use Indoors or in an Enclosure—8.3 kV Maximum (7.2 kV Nominal) 400A (For Use with 8RBA4 Fuseholders) ①

##### RBA Fuseholders, Mountings and Hardware (For Use with RBA/RBT Refills/Holders for Indoor or Enclosure Applications)

Ampere Rating	Style	Fuseholder		Voltage (kV)		LIWL (BIL)	Mounting (Including Live Parts Less Holder)		Live Parts	Fuse Filters and Condensers	Spring and Shunt Assy.
		Non-Indicating Catalog Number	Indicating Catalog Number	Nominal	Maximum		Porcelain Insulator	Glass Polyester			
0.5–400E	Non-disconnect	8RBA4-NH	8RBA4-INH	4.8	5.5	60	5RBA4-PNM	5RBA4-GNM	15RBA4-NL	RBA4-FLTR RBA4-COND	8RBA4-SHNT
	Non-disconnect	8RBA4-NH	8RBA4-INH	7.2	8.3	75	8RBA4-PNM	8RBA4-GNM	15RBA4-NL	RBA4-FLTR RBA4-COND	8RBA4-SHNT
	Disconnect	8RBA4-DH	8RBA4-IDH	4.8	5.5	60	5RBA4-PDM	5RBA4-GDM	14RBA4-DL	RBA4-FLTR RBA4-COND	8RBA4-SHNT
	Disconnect	8RBA4-DH	8RBA4-IDH	7.2	8.3	75	8RBA4-PDM	8RBA4-GDM	14RBA4-DL	RBA4-FLTR RBA4-COND	8RBA4-SHNT
	Bolt-in	—	8RBA2-INH-B	4.8	5.5	60	5RBA8-PNM	5RBA8-GNM	15RBA8-NL	RBA4-FLTR RBA4-COND	8RBA4-SHNT
	Bolt-in	—	8RBA4-INH-B	7.2	8.3	75	8RBA8-PNM	8RBA8-GNM	15RBA8-NL	RBA4-FLTR RBA4-COND	8RBA4-SHNT

#### Type RDB Expulsion Fuses for Use Outdoors—8.3 kV Maximum (7.2 kV Nominal) 400A ②

##### RDB Fuseholders, Mountings and Hardware (For Use with RBA/RBT Refills/Holders for Outdoor Applications)

Ampere Rating	Style	Fuseholder Catalog Number	Voltage (kV)		LIWL (BIL)	Mounting (Including Live Parts Less Holder)		Live Parts	Spring and Shunt Assy.	
			Nominal	Maximum		Vertical (180°) Mounting	Underhung (90°) Mounting			
0.5–400E	Dropout	8RDB4-DH	7.2	8.3	95	8RDB4-VM	8RDB4-UM	RDB4-VL	RDB4-UL	8RDB4-SHNT
	Dropout	8RDB4-DH	7.2	8.3	110	8RDB4-HVM	8RDB4-HUM	RDB4-VL	RDB4-UL	8RDB4-SHNT

##### Notes

- ① For new installation, order one refill (Standard Speed or Time Lag), one fuseholder, one mounting, and one filter or condenser per phase. Live parts can be substituted for the mounting if the user is supplying base support and insulators.
- ② For new installation, order one refill (Standard Speed or Time Lag), one fuseholder and one mounting per phase. Live parts can be substituted for the mounting if the user is supplying base support and insulators.

**Type 8RBA4 Expulsion Fuse Refill Units Used in 8RBA8/8RDB4 Fuseholders—  
8.3 kV Maximum (7.2 kV Nominal) 800A**

**RBA/RBT Refill Units**

Ampere Rating	Quantity	Standard Speed (Fuse Refills)		Quantity	Time Lag (Fuse Refills)		Approximate Shipping Weight Lbs (kg)
		Catalog Number	Curve Reference 36-635		Catalog Number	Curve Reference 36-635	
450E	2	8RBA4-250E	9	2	8RBT4-250E	12	①
540E	2	8RBA4-300E	9	2	8RBT4-300E	12	①
720E	2	8RBA4-400E	9	2	8RBT4-400E	12	①

**Type RBA Expulsion Fuses for Use Indoors or in an Enclosure—  
8.3 kV Maximum (7.2 kV Nominal) 800A (For Use with 8RBA8 Fuseholders) ②**

**RBA Fuseholders, Mountings and Hardware (For Use with RBA/RBT Refills/holders for Indoor or Enclosure Applications)**

Ampere Rating	Style	Fuseholder		Voltage (kV)		LIWL (BIL)	Mounting (Including Live Parts Less Holder)		Live Parts	Fuse Filters and Condensers	Spring and Shunt Assy.
		Non-Indicating Catalog Number	Indicating Catalog Number	Nominal	Maximum		Porcelain Insulator Catalog Number	Glass Polyester Catalog Number			
450E–720E	Non-disconnect	8RBA8-NH	8RBA8-INH	4.8	5.5	60	8RBA8-PNM	8RBA8-GNM	15RBA8-NL	RBA4-FLTR ③ RBA4-COND ③	8RBA4-SHNT
	Non-disconnect	8RBA8-NH	8RBA8-INH	7.2	8.3	75	8RBA8-PNM	8RBA8-GNM	15RBA8-NL	RBA4-FLTR ③ RBA4-COND ③	8RBA4-SHNT

**Type RDB Expulsion Fuses for Use Outdoors—8.3 kV Maximum (7.2 kV Nominal) 800A ④**

**RDB Fuseholders, Mountings and Hardware (For Use with RBA/RBT Refills/holders for Outdoor Applications)**

Ampere Rating	Style	Fuseholder Catalog Number	Voltage (kV)		LIWL (BIL)	Mounting (Including Live Parts Less Holder)		Live Parts	Spring and Shunt Assy.	
			Nominal	Maximum		Vertical (180°) Mounting Catalog Number	Underhung (90°) Mounting Catalog Number			
450E–720E	Disconnect	8RDB4-NH	7.2	8.3	95	8RDB8-VM	8RDB8-UM	RDB8-VL	RDB8-UL	8RDB4-SHNT
	Disconnect	8RDB4-NH	7.2	8.3	110	8RDB8-HVM	8RDB8-HUM	RDB8-VL	RDB8-UL	8RDB4-SHNT

**Notes**

- ① Requires two fuse refills as shown. Price each refill individually. Example: To order refill units for a 720E, 8.3 kV fuse, order two pieces of an 8RBA4-400E.
- ② For new installation, order two refills (Standard or Time Lag), one fuseholder, one mounting, and two filters or condensers per phase. Live parts can be substituted for the mounting if the user is supplying base support and insulators.
- ③ Two filters or condensers required.
- ④ For new installation, order two refills (Standard or Time Lag), one fuseholder and one mounting per phase. Live parts can be substituted for the mounting if the user is supplying base support and insulators.

#### Type 15RBA2 Expulsion Fuse Refill Units—15.5 kV Maximum (14.4 kV Nominal) 200A

##### RBA/RBT Refill Units

Ampere Rating	Standard Speed (Fuse Refills)		Time Lag (Fuse Refills)		Approximate Shipping Weight Lbs (kg)
	Catalog Number	Curve Reference 36-635	Catalog Number	Curve Reference 36-635	
10E	15RBA2-10E	1, 2	—	—	1.1 (0.5)
15E	15RBA2-15E	1, 2	—	—	1.1 (0.5)
20E	15RBA2-20E	1, 2	15RBT2-20E	3, 4	1.1 (0.5)
25E	15RBA2-25E	1, 2	15RBT2-25E	3, 4	1.1 (0.5)
30E	15RBA2-30E	1, 2	15RBT2-30E	3, 4	1.1 (0.5)
40E	15RBA2-40E	1, 2	15RBT2-40E	3, 4	1.1 (0.5)
50E	15RBA2-50E	1, 2	15RBT2-50E	3, 4	1.1 (0.5)
65E	15RBA2-65E	1, 2	15RBT2-65E	3, 4	1.1 (0.5)
80E	15RBA2-80E	1, 2	15RBT2-80E	3, 4	1.1 (0.5)
100E	15RBA2-100E	1, 2	15RBT2-100E	3, 4	1.1 (0.5)
125E	15RBA2-125E	1, 2	15RBT2-125E	3, 4	1.1 (0.5)
150E	15RBA2-150E	1, 2	15RBT2-150E	3, 4	1.1 (0.5)
200E	15RBA2-200E	1, 2	15RBT2-200E	3, 4	1.1 (0.5)

#### Type RBA Expulsion Fuses for Use Outdoors—15.5 kV Maximum (14.4 kV Nominal) 200A (For Use with 15RBA2 Fuseholders) ①

##### RBA Fuseholders, Mountings and Hardware (For Use with RBA/RBT Refills/Holders for Outdoor Applications)

Ampere Rating	Style	Fuseholder		Voltage (kV)		LIWL (BIL)	Mounting (Including Live Parts Less Holder)		Live Parts	Fuse Filters and Condensers	Spring and Shunt Assy.
		Non-Indicating Catalog Number	Indicating Catalog Number	Nominal	Maximum		Porcelain Insulator Catalog Number	Glass Polyester Catalog Number			
10E–200E	Non-disconnect	15RBA2-NH	15RBA2-INH	13.8	15.5	95	14RBA2-PNM	14RBA2-GNM	15RBA2-NL	RBA2-FLTR RBA2-COND	15RBA2-SHNT
	Non-disconnect	15RBA2-NH	15RBA2-INH	13.8	15.5	110	15RBA2-PNM	—	15RBA2-NL	RBA2-FLTR RBA2-COND	15RBA2-SHNT
	Disconnect	15RBA2-DH	15RBA2-IDH	13.8	15.5	95	14RBA2-PDM	14RBA2-GDM	38RBA2-DL	RBA2-FLTR RBA2-COND	15RBA2-SHNT
	Disconnect	15RBA2-DH	15RBA2-IDH	13.8	15.5	110	15RBA2-PDM	—	38RBA2-DL	RBA2-FLTR RBA2-COND	15RBA2-SHNT
	Bolt-in	—	15RBA2-INH-B	13.8	15.5	95	14RBA8-PNM	14RBA8-GNM	15RBA8-NL	RBA2-FLTR RBA2-COND	15RBA2-SHNT
	Bolt-in	—	15RBA2-INH-B	13.8	15.5	110	15RBA8-PNM	15RBA8-GNM	15RBA8-NL	RBA2-FLTR RBA2-COND	15RBA2-SHNT

#### Type RDB Expulsion Fuses for Use Outdoors—15.5 kV Maximum (14.4 kV Nominal) 200A ②

##### RDB Fuseholders, Mountings and Hardware (For Use with RBA/RBT Refills/Holders for Outdoor Applications)

Ampere Rating	Style	Fuseholder Catalog Number	Voltage (kV)		LIWL (BIL)	Mounting (Including Live Parts Less Holder)		Live Parts	Spring and Shunt Assy.	
			Nominal	Maximum		Vertical (180°) Mounting Catalog Number	Underhung (90°) Mounting Catalog Number			
10E–200E	Dropout	15RDB2-DH	13.8	15.5	110	15RDB2-VM	15RDB2-UM	RDB2-VL	RDB2-UL	15RDB2-SHNT
	Dropout	15RDB2-DH	13.8	15.5	150	15RDB2-HVM	15RDB2-HUM	RDB2-VL	RDB2-UL	15RDB2-SHNT

##### Notes

- ① For new installation, order one refill (Standard Speed or Time Lag), one fuseholder, one mounting, and one filter or condenser per phase. Live parts can be substituted for the mounting if the user is supplying base support and insulators.
- ② For new installation, order one refill (Standard Speed or Time Lag), one fuseholder and one mounting per phase. Live parts can be substituted for the mounting if the user is supplying base support and insulators.

**Type 15RBA4 Expulsion Fuse Refill Units—15.5 kV Maximum (14.4 kV Nominal) 400A**

**RBA/RBT Refill Units**

Ampere Rating	Standard Speed (Fuse Refills)		Time Lag (Fuse Refills)		Approximate Shipping Weight Lbs (kg)
	Catalog Number	Curve Reference 36-635	Catalog Number	Curve Reference 36-635	
0.5	15RBA4-.5	5, 6	—	—	2.3 (1.0)
3	15RBA4-3	5, 6	—	—	2.3 (1.0)
5E	15RBA4-5E	5, 6	—	—	2.3 (1.0)
7E	15RBA4-7E	5, 6	—	—	2.3 (1.0)
10E	15RBA4-10E	5, 6	—	—	2.3 (1.0)
15E	15RBA4-15E	5, 6	—	—	2.3 (1.0)
20E	15RBA4-20E	5, 6	15RBT4-20E	7, 8	2.3 (1.0)
25E	15RBA4-25E	5, 6	15RBT4-25E	7, 8	2.3 (1.0)
30E	15RBA4-30E	5, 6	15RBT4-30E	7, 8	2.3 (1.0)
40E	15RBA4-40E	5, 6	15RBT4-40E	7, 8	2.3 (1.0)
50E	15RBA4-50E	5, 6	15RBT4-50E	7, 8	2.3 (1.0)
65E	15RBA4-65E	5, 6	15RBT4-65E	7, 8	2.3 (1.0)
80E	15RBA4-80E	5, 6	15RBT4-80E	7, 8	2.3 (1.0)
100E	15RBA4-100E	5, 6	15RBT4-100E	7, 8	2.3 (1.0)
125E	15RBA4-125E	5, 6	15RBT4-125E	7, 8	2.3 (1.0)
150E	15RBA4-150E	5, 6	15RBT4-150E	7, 8	2.3 (1.0)
200E	15RBA4-200E	5, 6	15RBT4-200E	7, 8	2.3 (1.0)
250E	15RBA4-250E	5, 6	15RBT4-250E	10, 11	2.3 (1.0)
300E	15RBA4-300E	5, 6	15RBT4-300E	10, 11	2.3 (1.0)
400E	15RBA4-400E	5, 6	15RBT4-400E	10, 11	2.3 (1.0)

**Type RBA Expulsion Fuses for Use Outdoors—15.5 kV Maximum (14.4 kV Nominal) 400A (For Use with 15RBA4 Fuseholders) ①**

**RBA Fuseholders, Mountings and Hardware (For Use with RBA/RBT Refills/holders for Outdoor Applications)**

Ampere Rating	Style	Fuseholder		Voltage (kV)			Mounting (Including Live Parts Less Holder)		Live Parts	Fuse Filters and Condensers	Spring and Shunt Assy.
		Non-Indicating Catalog Number	Indicating Catalog Number	Nominal	Maximum	LIWL (BIL)	Porcelain Insulator Catalog Number	Glass Polyester Catalog Number			
0.5–400E	Non-disconnect	15RBA4-NH	15RBA4-INH	13.8	15.5	95	14RBA4-PNM	14RBA4-GNM	15RBA4-NL	RBA4-FLTR RBA4-COND	15RBA4-SHNT
	Non-disconnect	15RBA4-NH	15RBA4-INH	13.8	15.5	110	15RBA4-PNM	—	15RBA4-NL	RBA4-FLTR RBA4-COND	15RBA4-SHNT
	Disconnect	15RBA4-DH	15RBA2-IDH	13.8	15.5	95	14RBA4-PDM	14RBA4-GDM	15RBA4-DL	RBA4-FLTR RBA4-COND	15RBA4-SHNT
	Disconnect	15RBA4-DH	15RBA2-IDH	13.8	15.5	110	15RBA4-PDM	—	15RBA4-DL	RBA4-FLTR RBA4-COND	15RBA4-SHNT
	Bolt-in	—	15RBA4-INH-B	13.8	15.5	95	14RBA8-PNM	14RBA8-GNM	15RBA8-NL	RBA-FLTR RBA4-COND	15RBA4-SHNT
	Bolt-in	—	15RBA4-INH-B	13.8	15.5	110	15RBA8-PNM	15RBA8-GNM	15RBA8-NL	RBA-FLTR RBA4-COND	15RBA4-SHNT

**Type RDB Expulsion Fuses for Use Outdoors—15.5 kV Maximum (14.4 kV Nominal) 400A ②**

**RDB Fuseholders, Mountings and Hardware (For Use with RBA/RBT Refills/holders for Outdoor Applications)**

Ampere Rating	Style	Fuseholder Catalog Number	Voltage (kV)			Mounting (Including Live Parts Less Holder)		Live Parts	Spring and Shunt Assy.	
			Nominal	Maximum	LIWL (BIL)	Vertical (180°) Mounting Catalog Number	Underhung (90°) Mounting Catalog Number			
0.5–400E	Dropout	15RDB4-DH	13.8	15.5	110	15RDB4-VM	15RDB4-UM	RDB4-VL	RDB4-UL	15RDB4-SHNT
	Dropout	15RDB4-DH	13.8	15.5	150	15RDB4-HVM	15RDB4-HUM	RDB4-VL	RDB4-UL	15RDB4-SHNT

**Notes**

- ① For new installation, order one refill (Standard Speed or Time Lag), one fuseholder, one mounting, and one filter or condenser per phase. Live parts can be substituted for the mounting if the user is supplying base support and insulators.
- ② For new installation, order one refill (Standard Speed or Time Lag), one fuseholder and one mounting per phase. Live parts can be substituted for the mounting if the user is supplying base support and insulators.

#### Type 15RBA4 Expulsion Fuse Refill Units Used in 15RBA8/15RDB4 Fuseholders— 15.5 kV Maximum (14.4 kV Nominal) 800A

##### RBA/RBT Refill Units

Ampere Rating	Quantity	Standard Speed (Fuse Refills)		Quantity	Time Lag (Fuse Refills)		Approximate Shipping Weight Lbs (kg)
		Catalog Number	Curve Reference 36-635		Catalog Number	Curve Reference 36-635	
450E	2	15RBA4-250E	9	2	15RBT4-250E	12	①
540E	2	15RBA4-300E	9	2	15RBT4-300E	12	①
720E	2	15RBA4-400E	9	2	15RBT4-400E	12	①

#### Type RBA Expulsion Fuses for Use Outdoors— 15.5 kV Maximum (14.4 kV Nominal) 800A (For Use with 15RBA8 Fuseholders) ②

##### RBA Fuseholders, Mountings and Hardware (For Use with RBA/RBT Refills/holders for Outdoor Applications)

Ampere Rating	Style	Fuseholder		Voltage (kV)		LIWL (BIL)	Mounting (Including Live Parts Less Holder)		Live Parts	Fuse Filters and Condensers	Spring and Shunt Assy.
		Non-Indicating Catalog Number	Indicating Catalog Number	Nominal	Maximum		Porcelain Insulator	Glass Polyester			
450E–720E	Non-disconnect	15RBA8-NH	15RBA8-INH	13.8	15.5	95	14RBA8-PNM	14RBA8-GNM	15RBA8-NL	RBA4-FLTR ③	15RBA4-SHNT
										RBA4-COND ③	
	Non-disconnect	15RBA8-NH	15RBA8-INH	13.8	15.5	110	15RBA8-PNM	14RBA8-GNM	15RBA8-NL	RBA4-FLTR ③	15RBA4-SHNT
										RBA4-COND ③	

#### Type RDB Expulsion Fuses for Use Outdoors—15.5 kV Maximum (14.4 kV Nominal) 800A ④

##### RDB Fuseholders, Mountings and Hardware (For Use with RBA/RBT Refills/holders for Outdoor Applications)

Ampere Rating	Style	Fuseholder		Voltage (kV)		LIWL (BIL)	Mounting (Including Live Parts Less Holder)		Live Parts	Spring and Shunt Assy.
		Catalog Number	Nominal	Maximum	Vertical (180°) Mounting		Underhung (90°) Mounting			
450E–720E	Disconnect	15RDB4-NH	13.8	15.5	110	15RDB8-VM	15RDB8-UM	RDB8-VL	RDB8-UL	15RDB4-SHNT
	Disconnect	15RDB4-NH	13.8	15.5	150	15RDB8-HVM	15RDB8-HUM	RDB8-VL	RDB8-UL	15RDB4-SHNT

##### Notes

- ① Requires two fuse refills as shown. Price each refill individually. Example: To order refill units for a 720E, 15 kV fuse, order two pieces of an 8RBA4-400E.
- ② For new installation, order two refills (Standard or Time Lag), one fuseholder, one mounting, and two filters or condensers per phase. Live parts can be substituted for the mounting if the user is supplying base support and insulators.
- ③ Two filters or condensers required.
- ④ For new installation, order two refills (Standard or Time Lag), one fuseholder and one mounting per phase. Live parts can be substituted for the mounting if the user is supplying base support and insulators.

**Type 25RBA2 Expulsion Fuse Refill Units—25.5 kV Maximum (23.0 kV Nominal) 200A**

**RBA/RBT Refill Units**

Ampere Rating	Standard Speed (Fuse Refills)		Time Lag (Fuse Refills)		Approximate Shipping Weight Lbs (kg)
	Catalog Number	Curve Reference 36-635	Catalog Number	Curve Reference 36-635	
10E	25RBA2-10E	1, 2	—	—	1.3 (0.6)
15E	25RBA2-15E	1, 2	—	—	1.3 (0.6)
20E	25RBA2-20E	1, 2	25RBT2-20E	3, 4	1.3 (0.6)
25E	25RBA2-25E	1, 2	25RBT2-25E	3, 4	1.3 (0.6)
30E	25RBA2-30E	1, 2	25RBT2-30E	3, 4	1.3 (0.6)
40E	25RBA2-40E	1, 2	25RBT2-40E	3, 4	1.3 (0.6)
50E	25RBA2-50E	1, 2	25RBT2-50E	3, 4	1.3 (0.6)
65E	25RBA2-65E	1, 2	25RBT2-65E	3, 4	1.3 (0.6)
80E	25RBA2-80E	1, 2	25RBT2-80E	3, 4	1.3 (0.6)
100E	25RBA2-100E	1, 2	25RBT2-100E	3, 4	1.3 (0.6)
125E	25RBA2-125E	1, 2	25RBT2-125E	3, 4	1.3 (0.6)
150E	25RBA2-150E	1, 2	25RBT2-150E	3, 4	1.3 (0.6)
200E	25RBA2-200E	1, 2	25RBT2-200E	3, 4	1.3 (0.6)

**Type RBA Expulsion Fuses for Use Indoors or in an Enclosure—25.5 kV Maximum (23.0 kV Nominal) 200A (For Use with 25RBA2 Fuseholders)** ①

**RBA Fuseholders, Mountings and Hardware (For Use with RBA/RBT Refills/holders for Indoor or Enclosure Applications)**

Ampere Rating	Style	Fuseholder		Voltage (kV)			Mounting (Including Live Parts Less Holder)		Live Parts	Fuse Filters and Condensers	Spring and Shunt Assy.
		Non-Indicating Catalog Number	Indicating Catalog Number	Nominal	Maximum	LIWL (BIL)	Porcelain Insulator Catalog Number	Glass Polyester Catalog Number			
10E–200E	Non-disconnect	25RBA2-NH	25RBA2-INH	23.0	25.5	150	25RBA2-PNM	—	38RBA2-NL	RBA2-FLTR RBA2-COND	25RBA2-SHNT
	Non-disconnect	25RBA2-NH	25RBA2-INH	23.0	25.5	150	25RBA2-PNM	—	38RBA2-NL	RBA2-FLTR RBA2-COND	25RBA2-SHNT
	Disconnect	25RBA2-DH	25RBA2-IDH	23.0	25.5	150	25RBA2-PDM	—	38RBA2-DL	RBA2-FLTR RBA2-COND	25RBA2-SHNT
	Disconnect	25RBA2-DH	25RBA2-IDH	23.0	25.5	150	25RBA2-PDM	—	38RBA2-DL	RBA2-FLTR RBA2-COND	25RBA2-SHNT
	Bolt-in	—	25RBA2-INH-B	23.0	25.5	150	25RBA8-PNM	24RBA8-GNM	38RBA8-NL	RBA2-FLTR RBA2-COND	25RBA2-SHNT

**Type RDB Expulsion Fuses for Use Outdoors—25.5 kV Maximum (23.0 kV Nominal) 200A** ②

**RDB Fuseholders, Mountings and Hardware (For Use with RBA/RBT Refills/holders for Outdoor Applications)**

Ampere Rating	Style	Fuseholder Catalog Number	Voltage (kV)		LIWL (BIL)	Mounting (Including Live Parts Less Holder)		Live Parts	Spring and Shunt Assy.
			Nominal	Maximum		Vertical (180°) Mounting Catalog Number	Underhung (90°) Mounting Catalog Number		
10E–200E	Dropout	25RDB2-DH	23.0	25.5	150	25RDB2-VM	25RDB2-UM	RDB2-VL	RDB2-UL 25RDB2-SHNT
	Dropout	25RDB2-DH	23.0	25.5	200	25RDB2-HVM	25RDB2-HUM	RDB2-VL	RDB2-UL 25RDB2-SHNT

**Notes**

- ① For new installation, order one refill (Standard Speed or Time Lag), one fuseholder, one mounting, and one filter or condenser per phase. Live parts can be substituted for the mounting if the user is supplying base support and insulators.
- ② For new installation, order one refill (Standard Speed or Time Lag), one fuseholder and one mounting per phase. Live parts can be substituted for the mounting if the user is supplying base support and insulators.

#### Type 25RBA4 Expulsion Fuse Refill Units—25.5 kV Maximum (23.0 kV Nominal) 400A

##### RBA/RBT Refill Units

Ampere Rating	Standard Speed (Fuse Refills)		Time Lag (Fuse Refills)		Approximate Shipping Weight Lbs (kg)
	Catalog Number	Curve Reference 36-635	Catalog Number	Curve Reference 36-635	
0.5	25RBA4-5	5, 6	—	—	2.7 (1.2)
3	25RBA4-3	5, 6	—	—	2.7 (1.2)
5E	25RBA4-5E	5, 6	—	—	2.7 (1.2)
7E	25RBA4-7E	5, 6	—	—	2.7 (1.2)
10E	25RBA4-10E	5, 6	—	—	2.7 (1.2)
15E	25RBA4-15E	5, 6	—	—	2.7 (1.2)
20E	25RBA4-20E	5, 6	25RBT4-20E	7, 8	2.7 (1.2)
25E	25RBA4-25E	5, 6	25RBT4-25E	7, 8	2.7 (1.2)
30E	25RBA4-30E	5, 6	25RBT4-30E	7, 8	2.7 (1.2)
40E	25RBA4-40E	5, 6	25RBT4-40E	7, 8	2.7 (1.2)
50E	25RBA4-50E	5, 6	25RBT4-50E	7, 8	2.7 (1.2)
65E	25RBA4-65E	5, 6	25RBT4-65E	7, 8	2.7 (1.2)
80E	25RBA4-80E	5, 6	25RBT4-80E	7, 8	2.7 (1.2)
100E	25RBA4-100E	5, 6	25RBT4-100E	7, 8	2.7 (1.2)
125E	25RBA4-125E	5, 6	25RBT4-125E	7, 8	2.7 (1.2)
150E	25RBA4-150E	5, 6	25RBT4-150E	7, 8	2.7 (1.2)
200E	25RBA4-200E	5, 6	25RBT4-200E	7, 8	2.7 (1.2)
250E	25RBA4-250E	5, 6	25RBT4-250E	10, 11	2.7 (1.2)
300E	25RBA4-300E	5, 6	25RBT4-300E	10, 11	2.7 (1.2)

#### Type RBA Expulsion Fuses for Use Indoors or in an Enclosure—25.5 kV Maximum (23.0 kV Nominal) 400A (For Use with 25RBA4 Fuseholders) ①

##### RBA Fuseholders, Mountings and Hardware (For Use with RBA/RBT Refills/Holders for Indoor or Enclosure Applications)

Ampere Rating	Style	Fuseholder		Voltage (kV)		LIWL (BIL)	Mounting (Including Live Parts Less Holder)		Live Parts	Fuse Filters and Condensers	Spring and Shunt Assy.
		Non-Indicating Catalog Number	Indicating Catalog Number	Nominal	Maximum		Porcelain Insulator	Glass Polyester			
0.5–300E	Non-disconnect	25RBA4-NH	25RBA4-INH	23.0	25.5	150	25RBA4-PNM	—	38RBA4-NL	RBA4-FLTR RBA4-COND	25RBA4-SHNT
	Non-disconnect	25RBA4-NH	25RBA4-INH	23.0	25.5	150	25RBA4-PNM	—	38RBA4-NL	RBA4-FLTR RBA4-COND	25RBA4-SHNT
	Disconnect	25RBA4-DH	25RBA2-IDH	23.0	25.5	150	25RBA4-PDM	—	38RBA4-DL	RBA4-FLTR RBA4-COND	25RBA4-SHNT
	Disconnect	25RBA4-DH	25RBA2-IDH	23.0	25.5	150	25RBA4-PDM	—	38RBA4-DL	RBA4-FLTR RBA4-COND	25RBA4-SHNT
	Bolt-in	—	25RBA4-INH-B	23.0	25.5	150	25RBA8-PNM	25RBA8-GNM	38RBA8-NL	RBA4-FLTR RBA4-COND	25RBA4-SHNT

#### Type RDB Expulsion Fuses for Use Outdoors—25.5 kV Maximum (23.0 kV Nominal) 400A ②

##### RDB Fuseholders, Mountings and Hardware (For Use with RBA/RBT Refills/Holders for Outdoor Applications)

Ampere Rating	Style	Fuseholder Catalog Number	Voltage (kV)		LIWL (BIL)	Mounting (Including Live Parts Less Holder)		Live Parts	Spring and Shunt Assy.
			Nominal	Maximum		Vertical (180°) Mounting	Underhung (90°) Mounting		
0.5–300E	Dropout	25RDB4-DH	23.0	25.5	150	25RDB4-VM	25RDB4-UM	RDB4-VL	RDB4-UL 25RDB4-SHNT
	Dropout	25RDB4-DH	23.0	25.5	200	25RDB4-HVM	25RDB4-HUM	RDB4-VL	RDB4-UL 25RDB4-SHNT

##### Notes

- ① For new installation, order one refill (Standard Speed or Time Lag), one fuseholder and one mounting per phase. Live parts can be substituted for the mounting if the user is supplying base support and insulators.
- ② For new installation, order one refill (Standard Speed or Time Lag), one fuseholder, one mounting, and one filter or condenser per phase. Live parts can be substituted for the mounting if the user is supplying base support and insulators.

**Type 25RBA4 Expulsion Fuse Refill Units Used in 25RBA8/15RDB4 Fuseholders—  
25.5 kV Maximum (23.0 kV Nominal) 800A**

**RBA/RBT Refill Units**

Ampere Rating	Quantity	Standard Speed (Fuse Refills)		Quantity	Time Lag (Fuse Refills)		Approximate Shipping Weight Lbs (kg)
		Catalog Number	Curve Reference 36-635		Catalog Number	Curve Reference 36-635	
450E	2	25RBA4-250E	9	2	25RBT4-250E	12	①
540E	2	25RBA4-300E	9	2	25RBT4-300E	12	①

**Type RBA Expulsion Fuses for Use Indoors or in an Enclosure—  
25.5 kV Maximum (23.0 kV Nominal) 800A (For Use with 25RBA8 Fuseholders) ②**

**RBA Fuseholders, Mountings and Hardware (For Use with RBA/RBT Refills/holders for Indoor or Enclosure Applications)**

Ampere Rating	Style	Fuseholder		Voltage (kV)		LIWL (BIL)	Mounting (Including Live Parts Less Holder)		Live Parts	Fuse Filters and Condensers	Spring and Shunt Assy.
		Non-Indicating Catalog Number	Indicating Catalog Number	Nominal	Maximum		Porcelain Insulator Catalog Number	Glass Polyester Catalog Number			
450E–540E	Non-disconnect	25RBA8-NH	25RBA8-INH	23.0	25.5	150	25RBA8-PNM	—	38RBA8-NL	RBA4-FLTR ③ RBA4-COND ③	25RBA4-SHNT
	Non-disconnect	25RBA8-NH	25RBA8-INH	23.0	25.5	150	25RBA8-PNM	—	38RBA8-NL	RBA4-FLTR ③ RBA4-COND ③	25RBA4-SHNT

**Type RDB Expulsion Fuses for Use Outdoors—25.5 kV Maximum (23.0 kV Nominal) 800A ④**

**RDB Fuseholders, Mountings and Hardware (For Use with RBA/RBT Refills/holders for Outdoor Applications)**

Ampere Rating	Style	Fuseholder		Voltage (kV)		LIWL (BIL)	Mounting (Including Live Parts Less Holder)		Live Parts	Spring and Shunt Assy.	
		Catalog Number		Nominal	Maximum		Vertical (180°) Mounting Catalog Number	Underhung (90°) Mounting Catalog Number			
450E–540E	Disconnect	25RDB4-NH		23.0	25.5	150	25RDB8-VM	25RDB8-UM	RDB8-VL	RDB8-UL	25RDB4-SHNT
	Disconnect	25RDB4-NH		23.0	25.5	200	25RDB8-HVM	25RDB8-HUM	RDB8-VL	RDB8-UL	25RDB4-SHNT

**Notes**

- ① Requires two fuse refills as shown. Price each refill individually. Example: To order refill units for a 720E, 25 kV fuse, order two pieces of an 8RBA4-400E.
- ② For new installation, order two refills (Standard or Time Lag), one fuseholder, one mounting, and two filters or condensers per phase. Live parts can be substituted for the mounting if the user is supplying base support and insulators.
- ③ Two filters or condensers required.
- ④ For new installation, order two refills (Standard or Time Lag), one fuseholder and one mounting per phase. Live parts can be substituted for the mounting if the user is supplying base support and insulators.



#### Type 38RBA2 Expulsion Fuse Refill Units—38.0 kV Maximum (34.5 kV Nominal) 200A

##### RBA/RBT Refill Units

Ampere Rating	Standard Speed (Fuse Refills)		Time Lag (Fuse Refills)		Approximate Shipping Weight Lbs (kg)
	Catalog Number	Curve Reference 36-635	Catalog Number	Curve Reference 36-635	
10E	38RBA2-10E	1, 2	—	—	1.4 (0.6)
15E	38RBA2-15E	1, 2	—	—	1.4 (0.6)
20E	38RBA2-20E	1, 2	38RBT2-20E	3, 4	1.4 (0.6)
25E	38RBA2-25E	1, 2	38RBT2-25E	3, 4	1.4 (0.6)
30E	38RBA2-30E	1, 2	38RBT2-30E	3, 4	1.4 (0.6)
40E	38RBA2-40E	1, 2	38RBT2-40E	3, 4	1.4 (0.6)
50E	38RBA2-50E	1, 2	38RBT2-50E	3, 4	1.4 (0.6)
65E	38RBA2-65E	1, 2	38RBT2-65E	3, 4	1.4 (0.6)
80E	38RBA2-80E	1, 2	38RBT2-80E	3, 4	1.4 (0.6)
100E	38RBA2-100E	1, 2	38RBT2-100E	3, 4	1.4 (0.6)
125E	38RBA2-125E	1, 2	38RBT2-125E	3, 4	1.4 (0.6)
150E	38RBA2-150E	1, 2	38RBT2-150E	3, 4	1.4 (0.6)
200E	38RBA2-200E	1, 2	38RBT2-200E	3, 4	1.4 (0.6)

#### Type RBA Expulsion Fuses for Use Indoors or in an Enclosure—38.0 kV Maximum (34.5 kV Nominal) 200A (For Use with 38RBA2 Fuseholders) ①

##### RBA Fuseholders, Mountings and Hardware (For Use with RBA/RBT Refills/holders for Indoor or Enclosure Applications)

Ampere Rating	Style	Fuseholder		Voltage (kV)		LIWL (BIL)	Mounting (Including Live Parts Less Holder)		Live Parts	Fuse Filters and Condensers	Spring and Shunt Assy.
		Non-Indicating Catalog Number	Indicating Catalog Number	Nominal	Maximum		Porcelain Insulator Catalog Number	Glass Polyester Catalog Number			
10E–200E	Non-disconnect	38RBA2-NH	38RBA2-INH	34.5	38.0	150	38RBA2-PNM	—	38RBA2-NL	RBA2-FLTR RBA2-COND	38RBA2-SHNT
	Non-disconnect	38RBA2-NH	38RBA2-INH	34.5	38.0	150	38RBA2-PNM	—	38RBA2-NL	RBA2-FLTR RBA2-COND	38RBA2-SHNT
	Disconnect	38RBA2-DH	38RBA2-IDH	34.5	38.0	150	38RBA2-PDM	—	38RBA2-DL	RBA2-FLTR RBA2-COND	38RBA2-SHNT
	Disconnect	38RBA2-DH	38RBA2-IDH	34.5	38.0	150	38RBA2-PDM	—	38RBA2-DL	RBA2-FLTR RBA2-COND	38RBA2-SHNT
	Bolt-in	—	38RBA2-INH-B	34.5	38.0	150	38RBA8-PNM	38RBA8-GNM	38RBA8-NL	RBA2-FLTR RBA2-COND	38RBA2-SHNT

#### Type RBA Expulsion Fuses for Use Indoors or in an Enclosure—38.0 kV Maximum (34.5 kV Nominal) 200A ②

##### RDB Fuseholders, Mountings and Hardware (For Use with RBA/RBT Refills/holders for Outdoor Applications)

Ampere Rating	Style	Fuseholder		Voltage (kV)		LIWL (BIL)	Mounting (Including Live Parts Less Holder)		Live Parts	Spring and Shunt Assy.	
		Catalog Number		Nominal	Maximum		Vertical (180°) Mounting Catalog Number	Underhung (90°) Mounting Catalog Number			
10E–200E	Dropout	38RDB2-DH		34.5	38.0	200	38RDB2-VM	38RDB2-UM	RDB2-VL	RDB2-UL	38RDB2-SHNT
	Dropout	38RDB2-DH		34.5	38.0	250	38RDB2-HVM	38RDB2-HUM	RDB2-VL	RDB2-UL	38RDB2-SHNT

##### Notes

① For new installation, order one refill (Standard Speed or Time Lag), one fuseholder, one mounting, and one filter or condenser per phase. Live parts can be substituted for the mounting if the user is supplying base support and insulators.

② For new installation, order one refill (Standard Speed or Time Lag), one fuseholder and one mounting per phase. Live parts can be substituted for the mounting if the user is supplying base support and insulators.

**Type 38RBA4 Expulsion Fuse Refill Units—38.0 kV Maximum (34.5 kV Nominal) 400A**

**RBA/RBT Refill Units**

Ampere Rating	Standard Speed (Fuse Refills)		Time Lag (Fuse Refills)		Approximate Shipping Weight Lbs (kg)
	Catalog Number	Curve Reference 36-635	Catalog Number	Curve Reference 36-635	
0.5	38RBA4-5	5, 6	—	—	3.1 (1.4)
3	38RBA4-3	5, 6	—	—	3.1 (1.4)
5E	38RBA4-5E	5, 6	—	—	3.1 (1.4)
7E	38RBA4-7E	5, 6	—	—	3.1 (1.4)
10E	38RBA4-10E	5, 6	—	—	3.1 (1.4)
15E	38RBA4-15E	5, 6	—	—	3.1 (1.4)
20E	38RBA4-20E	5, 6	38RBT4-20E	7, 8	3.1 (1.4)
25E	38RBA4-25E	5, 6	38RBT4-25E	7, 8	3.1 (1.4)
30E	38RBA4-30E	5, 6	38RBT4-30E	7, 8	3.1 (1.4)
40E	38RBA4-40E	5, 6	38RBT4-40E	7, 8	3.1 (1.4)
50E	38RBA4-50E	5, 6	38RBT4-50E	7, 8	3.1 (1.4)
65E	38RBA4-65E	5, 6	38RBT4-65E	7, 8	3.1 (1.4)
80E	38RBA4-80E	5, 6	38RBT4-80E	7, 8	3.1 (1.4)
100E	38RBA4-100E	5, 6	38RBT4-100E	7, 8	3.1 (1.4)
125E	38RBA4-125E	5, 6	38RBT4-125E	7, 8	3.1 (1.4)
150E	38RBA4-150E	5, 6	38RBT4-150E	7, 8	3.1 (1.4)
200E	38RBA4-200E	5, 6	38RBT4-200E	7, 8	3.1 (1.4)
250E	38RBA4-250E	5, 6	38RBT4-250E	10, 11	3.1 (1.4)
300E	38RBA4-300E	5, 6	38RBT4-300E	(0, 11)	3.1 (1.4)

**Type RBA Expulsion Fuses for Use Indoors or in an Enclosure—38.0 kV Maximum (34.5 kV Nominal) 400A (For Use with 38RBA4 Fuseholders) ①**

**RBA Fuseholders, Mountings and Hardware (For Use with RBA/RBT Refills/holders for Indoor or Enclosure Applications)**

Ampere Rating	Style	Fuseholder		Voltage (kV)		Mounting (Including Live Parts Less Holder)		Live Parts	Fuse Filters and Condensers	Spring and Shunt Assy.	
		Non-Indicating Catalog Number	Indicating Catalog Number	Nominal	Maximum	Porcelain Insulator LIWL (BIL)	Glass Polyester Catalog Number				
0.5–300E	Non-disconnect	38RBA4-NH	38RBA4-INH	34.5	38.0	150	38RBA4-PNM	—	38RBA4-NL	RBA4-FLTR RBA4-COND	38RBA4-SHNT
	Non-disconnect	38RBA4-NH	38RBA4-INH	34.5	38.0	150	38RBA4-PNM	—	38RBA4-NL	RBA4-FLTR RBA4-COND	38RBA4-SHNT
	Disconnect	38RBA4-DH	38RBA2-IDH	34.5	38.0	150	38RBA4-PDM	—	38RBA4-DL	RBA4-FLTR RBA4-COND	38RBA4-SHNT
	Disconnect	38RBA4-DH	38RBA2-IDH	34.5	38.0	150	38RBA4-PDM	—	38RBA4-DL	RBA4-FLTR RBA4-COND	38RBA4-SHNT
	Bolt-in	—	38RBA4-INH-B	34.5	38.0	150	38RBA8-PNM	38RBA8-GNM	38RBA8-NL	RBA4-FLTR RBA4-COND	38RBA4-SHNT

**Type RBA Expulsion Fuses for Use Indoors or in an Enclosure—38.0 kV Maximum (34.5 kV Nominal) 400A ②**

**RDB Fuseholders, Mountings and Hardware (For Use with RBA/RBT Refills/holders for Outdoor Applications)**

Ampere Rating	Style	Fuseholder Catalog Number	Voltage (kV)		LIWL (BIL)	Mounting (Including Live Parts Less Holder)		Live Parts	Spring and Shunt Assy.	
			Nominal	Maximum		Vertical (180°) Mounting Catalog Number	Underhung (90°) Mounting Catalog Number			
0.5–300E	Dropout	38RDB4-DH	34.5	38.0	150	38RDB4-VM	38RDB4-UM	RDB4-VL	RDB4-UL	38RDB4-SHNT
	Dropout	38RDB4-DH	34.5	38.0	200	38RDB4-HVM	38RDB4-HUM	RDB4-VL	RDB4-UL	38RDB4-SHNT

**Notes**

- ① For new installation, order one refill (Standard Speed or Time Lag), one fuseholder, one mounting, and one filter or condenser per phase. Live parts can be substituted for the mounting if the user is supplying base support and insulators.
- ② For new installation, order one refill (Standard Speed or Time Lag), one fuseholder and one mounting per phase. Live parts can be substituted for the mounting if the user is supplying base support and insulators.

#### Type 38RBA4 Expulsion Fuse Refill Units Used in 38RBA8/15RDB4 Fuseholders—38.0 kV Maximum (34.5 kV Nominal) 800A

##### RBA/RBT Refill Units

Ampere Rating	Quantity	Standard Speed (Fuse Refills)		Quantity	Time Lag (Fuse Refills)		Approximate Shipping Weight Lbs (kg)
		Catalog Number	Curve Reference 36-635		Catalog Number	Curve Reference 36-635	
450E	2	38RBA4-250E	9	2	38RBT4-250E	12	①
540E	2	38RBA4-300E	9	2	38RBT4-300E	12	①

#### Type RBA Expulsion Fuses for Use Indoors or in an Enclosure—38.0 kV Maximum (34.5 kV Nominal) 800A (For Use with 38RBA8 Fuseholders) ②

##### RBA Fuseholders, Mountings and Hardware (For Use with RBA/RBT Refills/holders for Indoor or Enclosure Applications)

Ampere Rating	Style	Fuseholder		Voltage (kV)		LIWL (BIL)	Mounting (Including Live Parts Less Holder)		Live Parts	Fuse Filters and Condensers	Spring and Shunt Assy.
		Non-Indicating Catalog Number	Indicating Catalog Number	Nominal	Maximum		Porcelain Insulator	Glass Polyester			
450E–540E	Non-disconnect	38RBA8-NH	38RBA8-INH	34.5	38.0	150	38RBA8-PNM	—	38RBA8-NL	RBA4-FLTR ③ RBA4-COND ③	38RBA4-SHNT
	Non-disconnect	38RBA8-NH	38RBA8-INH	34.5	38.0	150	38RBA8-PNM	—	38RBA8-NL	RBA4-FLTR ③ RBA4-COND ③	38RBA4-SHNT

#### Type RBA Expulsion Fuses for Use Indoors or in an Enclosure—38.0 kV Maximum (34.5 kV Nominal) 800A ④

##### RDB Fuseholders, Mountings and Hardware (For Use with RBA/RBT Refills/holders for Outdoor Applications)

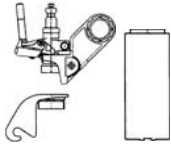
Ampere Rating	Style	Fuseholder		Voltage (kV)		LIWL (BIL)	Mounting (Including Live Parts Less Holder)		Live Parts	Spring and Shunt Assy.
		Catalog Number	Nominal	Maximum	Vertical (180°) Mounting		Underhung (90°) Mounting			
450E–540E	Disconnect	38RDB4-NH	34.5	38.0	150	38RDB8-VM	38RDB8-UM	RDB8-VL	RDB8-UL	38RDB4-SHNT
	Disconnect	38RDB4-NH	34.5	38.0	200	38RDB8-HVM	38RDB8-HUM	RDB8-VL	RDB8-UL	38RDB4-SHNT

##### Notes

- ① Requires two fuse refills as shown. Price each refill individually. Example: To order refill units for a 720E, 38 kV fuse, order 2 pieces of an 8RBA4-400E.
- ② For new installation, order two refills (Standard or Time Lag), one fuseholder, one mounting, and two filters or condensers per phase. Live parts can be substituted for the mounting if the user is supplying base support and insulators.
- ③ Two filters or condensers required.
- ④ For new installation, order two refills (Standard or Time Lag), one fuseholder and one mounting per phase. Live parts can be substituted for the mounting if the user is supplying base support and insulators.

Type DBU

DBU-EFID



Type DBU Expulsion Fuse Units 17.1 kV Maximum, 14.4 kV Nominal

Ampere Rating	Standard Speed			Slow Speed			K Speed		
	Catalog Number ①②	Curve Reference 36-643	Ampere Rating	Catalog Number ①②	Curve Reference 36-643	Ampere Rating	Catalog Number ①②	Curve Reference 36-643	
5E	DBU17-5E	11,14	—	—	—	3K	DBU17-3K	12, 15	
7E	DBU17-7E	11,14	—	—	—	6K	DBU17-6K	12, 15	
10E	DBU17-10E	11,14	—	—	—	8K	DBU17-8K	12, 15	
13E	DBU17-13E	11,14	—	—	—	10K	DBU17-10K	12, 15	
15E	DBU17-15E	11,14	15SE	DBU17-15SE	10, 13	12K	DBU17-12K	12, 15	
20E	DBU17-20E	11,14	20SE	DBU17-20SE	10, 13	15K	DBU17-15K	12, 15	
25E	DBU17-25E	11,14	25SE	DBU17-25SE	10, 13	20K	DBU17-20K	12, 15	
30E	DBU17-30E	11,14	30SE	DBU17-30SE	10, 13	25K	DBU17-25K	12, 15	
40E	DBU17-40E	11,14	40SE	DBU17-40SE	10, 13	30K	DBU17-30K	12, 15	
50E	DBU17-50E	11,14	50SE	DBU17-50SE	10, 13	40K	DBU17-40K	12, 15	
65E	DBU17-65E	11,14	65SE	DBU17-65SE	10, 13	50K	DBU17-50K	12, 15	
80E	DBU17-80E	11,14	80SE	DBU17-80SE	10, 13	65K	DBU17-65K	12, 15	
100E	DBU17-100E	11,14	100SE	DBU17-100SE	10, 13	80K	DBU17-80K	12, 15	
125E	DBU17-125E	11,14	125SE	DBU17-125SE	10, 13	100K	DBU17-100K	12, 15	
150E	DBU17-150E	11,14	150SE	DBU17-150SE	10, 13	140K	DBU17-140K	12, 15	
175E	DBU17-175E	11,14	175SE	DBU17-175SE	10, 13	200K	DBU17-200K	12, 15	
200E	DBU17-200E	11,14	200SE	DBU17-200SE	10, 13	—	—	—	

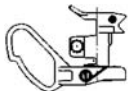
DBU17-GNM



DBU17-GDM



DBU-EFOD



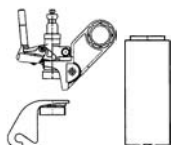
Type DBU Expulsion Fuse Mountings 17.1 kV Maximum, 14.4 kV Nominal

Ampere Rating	Style		Voltage (kV)			Mounting	Live Parts	End Fittings	Muffler
	Indoor	Non loadbreak	Nominal	Maximum	LIWL (BIL)				
5E–200E, 15SE–200SE, 3K–200K	Indoor	Non loadbreak	13.8	17.1	95	DBU17-GNM ③	DBU17-NL ③	DBU-EFID ④	DBU-MFLR
	Indoor	Loadbreak	13.8	17.1	95	DBU17-GDM ③	DBU17-DL ③	DBU-EFID ④	DBU-MFLR
	Outdoor	Dropout	13.8	17.1	125	DBU-17-DM	—	DBU-EFOD	—

Notes

- ① Maximum interrupting rating 14 kA symmetrical.
- ② Approximate shipping weight 2.1 lb (0.95 kg).
- ③ To complete the mounting catalog number, specify -R for right side cable terminator or -L for left side cable terminator.
- ④ End fittings DBU-EFID include a muffler.

**DBU-EFID**



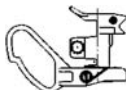
**DBU17-GNM**



**DBU17-GDM**



**DBU-EFOD**



**Type DBU Expulsion Fuse Units 27.0 kV Maximum, 25 kV Nominal**

Ampere Rating	Standard Speed			Slow Speed			K Speed		
	Catalog Number ①②	Curve Reference 36-643	Ampere Rating	Catalog Number ①②	Curve Reference 36-643	Ampere Rating	Catalog Number ①②	Curve Reference 36-643	
5E	DBU27-5E	11,17	—	—	—	3K	DBU27-3K	12, 18	
7E	DBU27-7E	11,17	—	—	—	6K	DBU27-6K	12, 18	
10E	DBU27-10E	11,17	—	—	—	8K	DBU27-8K	12, 18	
13E	DBU27-13E	11,17	—	—	—	10K	DBU27-10K	12, 18	
15E	DBU27-15E	11,17	15SE	DBU27-15SE	10, 16	12K	DBU27-12K	12, 18	
20E	DBU27-20E	11,17	20SE	DBU27-20SE	10, 16	15K	DBU27-15K	12, 18	
25E	DBU27-25E	11,17	25SE	DBU27-25SE	10, 16	20K	DBU27-20K	12, 18	
30E	DBU27-30E	11,17	30SE	DBU27-30SE	10, 16	25K	DBU27-25K	12, 18	
40E	DBU27-40E	11,17	40SE	DBU27-40SE	10, 16	30K	DBU27-30K	12, 18	
50E	DBU27-50E	11,17	50SE	DBU27-50SE	10, 16	40K	DBU27-40K	12, 18	
65E	DBU27-65E	11,17	65SE	DBU27-65SE	10, 16	50K	DBU27-50K	12, 18	
80E	DBU27-80E	11,17	80SE	DBU27-80SE	10, 16	65K	DBU27-65K	12, 18	
100E	DBU27-100E	11,17	100SE	DBU27-100SE	10, 16	80K	DBU27-80K	12, 18	
125E	DBU27-125E	11,17	125SE	DBU27-125SE	10, 16	100K	DBU27-100K	12, 18	
150E	DBU27-150E	11,17	150SE	DBU27-150SE	10, 16	140K	DBU27-140K	12, 18	
175E	DBU27-175E	11,17	175SE	DBU27-175SE	10, 16	200K	DBU27-200K	12, 18	
200E	DBU27-200E	11,17	200SE	DBU27-200SE	10, 16	—	—	—	

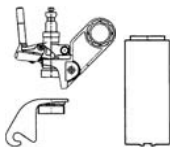
**Type DBU Expulsion Fuse Mountings 27.0 kV Maximum, 25 kV Nominal**

Ampere Rating	Style		Voltage (kV)			Mounting	Live Parts	End Fittings	Muffler
	Style	Style	Nominal	Maximum	LIWL (BIL)				
5E–200E, 15SE–200SE, 3K–200K	Indoor	Non loadbreak	23.5	27.0	110	DBU27-GNM ③	DBU27-NL ③	DBU-EFID ④	DBU-MFLR
	Indoor	Loadbreak	23.5	27.0	110	DBU27-GDM ③	DBU27-DL ③	DBU-EFID ④	DBU-MFLR
	Outdoor	Dropout	23.5	27.0	150	DBU-27-DM	—	DBU-EFOD	—

**Notes**

- ① Maximum interrupting rating 12.5kA symmetrical.
- ② Approximate shipping weight 2.1 lb (0.95 kg).
- ③ To complete the mounting catalog number, specify -R for right side cale terminator or -L for left side cale terminator.
- ④ End fittings DBU-EFID include a muffler.

**DBU-EFID**



**Type DBU Expulsion Fuse Units 38.8 kV Maximum, 34.5 kV Nominal**

Ampere Rating	Standard Speed			Slow Speed			K Speed		
	Catalog Number ①②	Curve Reference 36-643	Ampere Rating	Catalog Number ②	Curve Reference 36-643	Ampere Rating	Catalog Number ①②	Curve Reference 36-643	
5E	DBU38-5E	11,17	—	—	—	3K	DBU38-3K	12, 18	
7E	DBU38-7E	11,17	—	—	—	6K	DBU38-6K	12, 18	
10E	DBU38-10E	11,17	—	—	—	8K	DBU38-8K	12, 18	
13E	DBU38-13E	11,17	—	—	—	10K	DBU38-10K	12, 18	
15E	DBU38-15E	11,17	15SE	DBU38-15SE	10, 16	12K	DBU38-12K	12, 18	
20E	DBU38-20E	11,17	20SE	DBU38-20SE	10, 16	15K	DBU38-15K	12, 18	
25E	DBU38-25E	11,17	25SE	DBU38-25SE	10, 16	20K	DBU38-20K	12, 18	
30E	DBU38-30E	11,17	30SE	DBU38-30SE	10, 16	25K	DBU38-25K	12, 18	
40E	DBU38-40E	11,17	40SE	DBU38-40SE	10, 16	30K	DBU38-30K	12, 18	
50E	DBU38-50E	11,17	50SE	DBU38-50SE	10, 16	40K	DBU38-40K	12, 18	
65E	DBU38-65E	11,17	65SE	DBU38-65SE	10, 16	50K	DBU38-50K	12, 18	
80E	DBU38-80E	11,17	80SE	DBU38-80SE	10, 16	65K	DBU38-65K	12, 18	
100E	DBU38-100E	11,17	100SE	DBU38-100SE	10, 16	80K	DBU38-80K	12, 18	
125E	DBU38-125E	11,17	125SE	DBU38-125SE	10, 16	100K	DBU38-100K	12, 18	
150E	DBU38-150E	11,17	150SE	DBU38-150SE	10, 16	140K	DBU38-140K	12, 18	
175E	DBU38-175E	11,17	175SE	DBU38-175SE	10, 16	200K	DBU38-200K	12, 18	
200E	DBU38-200E	11,17	200SE	DBU38-200SE	10, 16	—	—	—	

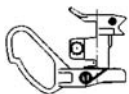
**DBU17-GNM**



**DBU17-GDM**



**DBU-EFOD**



**Type DBU Expulsion Fuse Mountings 38.0 kV Maximum, 34.5 kV Nominal**

Ampere Rating	Style		Voltage (kV)			Mounting	Live Parts	End Fittings	Muffer
	Indoor	Non loadbreak	Nominal	Maximum	LIWL (BIL)				
5E–200E, 15SE–200SE, 3K–200K	Indoor	Non loadbreak	34.5	38	150	DBU38-GNM ③	DBU38-NL ③	DBU-EFID ④	DBU-MFLR

**Notes**

- ① Maximum interrupting rating 10 kA symmetrical (outdoor dropout, 8.5 kA indoor with muffer).
- ② Approximate shipping weight 2.1 lb (0.95 kg).
- ③ To complete the mounting catalog number, specify -R for right side cale terminator or -L for left side cale terminator.
- ④ End fittings DBU-EFID includes a muffer.

## Technical Data and Specifications

## Type DBA

## Type DBA Expulsion Fuses for Use Indoors or Outdoors

Ampere Rating	DBA-1 Fuse Units Catalog Number	Curve Reference 36-623	Approximate Shipping Weight Lbs (kg)
<b>Type DBA-1 Fuse Refills 8.3 kV Maximum (7.2 kV Nominal)</b>			
0.5	8DBA1-5	10, 11	1.5 (0.7)
3	8DBA1-3	10, 11	1.5 (0.7)
5E	8DBA1-5E	10, 11	1.5 (0.7)
7E	8DBA1-7E	10, 11	1.5 (0.7)
10E	8DBA1-10E	10, 11	1.5 (0.7)
15E	8DBA1-15E	10, 11	1.5 (0.7)
20E	8DBA1-20E	10, 11	1.5 (0.7)
25E	8DBA1-25E	10, 11	1.5 (0.7)
30E	8DBA1-30E	10, 11	1.5 (0.7)
40E	8DBA1-40E	10, 11	1.5 (0.7)
50E	8DBA1-50E	10, 11	1.5 (0.7)
65E	8DBA1-65E	10, 11	1.5 (0.7)
80E	8DBA1-80E	10, 11	1.5 (0.7)
100E	8DBA1-100E	10, 11	1.5 (0.7)
125E	8DBA1-125E	10, 11	1.5 (0.7)
150E	8DBA1-150E	10, 11	1.5 (0.7)
200E	8DBA1-200E	10, 11	1.5 (0.7)
<b>15.5 kV Maximum (14.4 kV Nominal)</b>			
0.5	15DBA1-5	10, 11	2.1 (0.95)
3	15DBA1-3	10, 11	2.1 (0.95)
5E	15DBA1-5E	10, 11	2.1 (0.95)
7E	15DBA1-7E	10, 11	2.1 (0.95)
10E	15DBA1-10E	10, 11	2.1 (0.95)
15E	15DBA1-15E	10, 11	2.1 (0.95)
20E	15DBA1-20E	10, 11	2.1 (0.95)
25E	15DBA1-25E	10, 11	2.1 (0.95)
30E	15DBA1-30E	10, 11	2.1 (0.95)
40E	15DBA1-40E	10, 11	2.1 (0.95)
50E	15DBA1-50E	10, 11	2.1 (0.95)
65E	15DBA1-65E	10, 11	2.1 (0.95)
80E	15DBA1-80E	10, 11	2.1 (0.95)
100E	15DBA1-100E	10, 11	2.1 (0.95)
125E	15DBA1-125E	10, 11	2.1 (0.95)
150E	15DBA1-150E	10, 11	2.1 (0.95)
200E	15DBA1-200E	10, 11	2.1 (0.95)

Ampere Rating	DBA-1 Fuse Units Catalog Number	Curve Reference 36-623	Approximate Shipping Weight Lbs (kg)
<b>25 kV Maximum (23 kV Nominal)</b>			
0.5	25DBA1-5	10, 11	3.1 (1.4)
3	25DBA1-3	10, 11	3.1 (1.4)
5E	25DBA1-5E	10, 11	3.1 (1.4)
7E	25DBA1-7E	10, 11	3.1 (1.4)
10E	25DBA1-10E	10, 11	3.1 (1.4)
15E	25DBA1-15E	10, 11	3.1 (1.4)
20E	25DBA1-20E	10, 11	3.1 (1.4)
25E	25DBA1-25E	10, 11	3.1 (1.4)
30E	25DBA1-30E	10, 11	3.1 (1.4)
40E	25DBA1-40E	10, 11	3.1 (1.4)
50E	25DBA1-50E	10, 11	3.1 (1.4)
65E	25DBA1-65E	10, 11	3.1 (1.4)
80E	25DBA1-80E	10, 11	3.1 (1.4)
100E	25DBA1-100E	10, 11	3.1 (1.4)
125E	25DBA1-125E	10, 11	3.1 (1.4)
150E	25DBA1-150E	10, 11	3.1 (1.4)
200E	25DBA1-200E	10, 11	3.1 (1.4)

Type DBA Expulsion Fuses for Use Indoors or Outdoors,  
continued

Ampere Rating	DBA-1 Fuse Units Catalog Number	Curve Reference 36-623	Approximate Shipping Weight Lbs (kg)
<b>Type DBA-1 Fuse Refills</b>			
<b>38 kV Maximum (34.5 kV Nominal)</b>			
0.5	<b>38DBA1-5</b>	10, 12	4.2 (1.9)
3	<b>38DBA1-3</b>	10, 12	4.2 (1.9)
5E	<b>38DBA1-5E</b>	10, 12	4.2 (1.9)
7E	<b>38DBA1-7E</b>	10, 12	4.2 (1.9)
10E	<b>38DBA1-10E</b>	10, 12	4.2 (1.9)
15E	<b>38DBA1-15E</b>	10, 12	4.2 (1.9)
20E	<b>38DBA1-20E</b>	10, 12	4.2 (1.9)
25E	<b>38DBA1-25E</b>	10, 12	4.2 (1.9)
30E	<b>38DBA1-30E</b>	10, 12	4.2 (1.9)
40E	<b>38DBA1-40E</b>	10, 12	4.2 (1.9)
50E	<b>38DBA1-50E</b>	10, 12	4.2 (1.9)
65E	<b>38DBA1-65E</b>	10, 12	4.2 (1.9)
80E	<b>38DBA1-80E</b>	10, 12	4.2 (1.9)
100E	<b>38DBA1-100E</b>	10, 12	4.2 (1.9)
125E	<b>38DBA1-125E</b>	10, 12	4.2 (1.9)
150E	<b>38DBA1-150E</b>	10, 12	4.2 (1.9)
200E	<b>38DBA1-200E</b>	10, 12	4.2 (1.9)
<b>48 kV Maximum (46 kV Nominal)</b>			
0.5	<b>48DBA1-5</b>	10, 12	6.5 (3.0)
3	<b>48DBA1-3</b>	10, 12	6.5 (3.0)
5E	<b>48DBA1-5E</b>	10, 12	6.5 (3.0)
7E	<b>48DBA1-7E</b>	10, 12	6.5 (3.0)
10E	<b>48DBA1-10E</b>	10, 12	6.5 (3.0)
15E	<b>48DBA1-15E</b>	10, 12	6.5 (3.0)
20E	<b>48DBA1-20E</b>	10, 12	6.5 (3.0)
25E	<b>48DBA1-25E</b>	10, 12	6.5 (3.0)
30E	<b>48DBA1-30E</b>	10, 12	6.5 (3.0)
40E	<b>48DBA1-40E</b>	10, 12	6.5 (3.0)
50E	<b>48DBA1-50E</b>	10, 12	6.5 (3.0)
65E	<b>48DBA1-65E</b>	10, 12	6.5 (3.0)
80E	<b>48DBA1-80E</b>	10, 12	6.5 (3.0)
100E	<b>48DBA1-100E</b>	10, 12	6.5 (3.0)
125E	<b>48DBA1-125E</b>	10, 12	6.5 (3.0)
150E	<b>48DBA1-150E</b>	10, 12	6.5 (3.0)
200E	<b>48DBA1-200E</b>	10, 12	6.5 (3.0)

Ampere Rating	DBA-1 Fuse Units Catalog Number	Curve Reference 36-623	Approximate Shipping Weight Lbs (kg)
<b>72 kV Maximum (69 kV Nominal)</b>			
0.5	<b>72DBA1-5</b>	10, 12	7.1 (3.2)
3	<b>72DBA1-3</b>	10, 12	7.1 (3.2)
5E	<b>72DBA1-5E</b>	10, 12	7.1 (3.2)
7E	<b>72DBA1-7E</b>	10, 12	7.1 (3.2)
10E	<b>72DBA1-10E</b>	10, 12	7.1 (3.2)
15E	<b>72DBA1-15E</b>	10, 12	7.1 (3.2)
20E	<b>72DBA1-20E</b>	10, 12	7.1 (3.2)
25E	<b>72DBA1-25E</b>	10, 12	7.1 (3.2)
30E	<b>72DBA1-30E</b>	10, 12	7.1 (3.2)
40E	<b>72DBA1-40E</b>	10, 12	7.1 (3.2)
50E	<b>72DBA1-50E</b>	10, 12	7.1 (3.2)
65E	<b>72DBA1-65E</b>	10, 12	7.1 (3.2)
80E	<b>72DBA1-80E</b>	10, 12	7.1 (3.2)
100E	<b>72DBA1-100E</b>	10, 12	7.1 (3.2)
125E	<b>72DBA1-125E</b>	10, 12	7.1 (3.2)
150E	<b>72DBA1-150E</b>	10, 12	7.1 (3.2)
200E	<b>72DBA1-200E</b>	10, 12	7.1 (3.2)



Type DBA Expulsion Fuses for Use Indoors or Outdoors,  
continued

Ampere Rating	DBA-1 Fuse Units Catalog Number	Curve Reference 36-623	Approximate Shipping Weight Lbs (kg)
<b>Type DBA-2 Fuse Refills</b>			
<b>38 kV Maximum (34.5 kV Nominal)</b>			
0.5	38DBA2-5	10, 12	10 (4.5)
3	38DBA2-3	10, 12	10 (4.5)
5E	38DBA2-5E	10, 12	10 (4.5)
7E	38DBA2-7E	10, 12	10 (4.5)
10E	38DBA2-10E	10, 12	10 (4.5)
15E	38DBA2-15E	10, 12	10 (4.5)
20E	38DBA2-20E	10, 12	10 (4.5)
25E	38DBA2-25E	10, 12	10 (4.5)
30E	38DBA2-30E	10, 12	10 (4.5)
40E	38DBA2-40E	10, 12	10 (4.5)
50E	38DBA2-50E	10, 12	10 (4.5)
65E	38DBA2-65E	10, 12	10 (4.5)
80E	38DBA2-80E	10, 12	10 (4.5)
100E	38DBA2-100E	10, 12	10 (4.5)
125E	38DBA2-125E	10, 12	10 (4.5)
150E	38DBA2-150E	10, 12	10 (4.5)
200E	38DBA2-200E	10, 12	10 (4.5)
<b>48 kV Maximum (46 kV Nominal)</b>			
0.5	48DBA2-5	10, 12	12 (5.4)
3	48DBA2-3	10, 12	12 (5.4)
5E	48DBA2-5E	10, 12	12 (5.4)
7E	48DBA2-7E	10, 12	12 (5.4)
10E	48DBA2-10E	10, 12	12 (5.4)
15E	48DBA2-15E	10, 12	12 (5.4)
20E	48DBA2-20E	10, 12	12 (5.4)
25E	48DBA2-25E	10, 12	12 (5.4)
30E	48DBA2-30E	10, 12	12 (5.4)
40E	48DBA2-40E	10, 12	12 (5.4)
50E	48DBA2-50E	10, 12	12 (5.4)
65E	48DBA2-65E	10, 12	12 (5.4)
80E	48DBA2-80E	10, 12	12 (5.4)
100E	48DBA2-100E	10, 12	12 (5.4)
125E	48DBA2-125E	10, 12	12 (5.4)
150E	48DBA2-150E	10, 12	12 (5.4)
200E	48DBA2-200E	10, 12	12 (5.4)

Ampere Rating	DBA-1 Fuse Units Catalog Number	Curve Reference 36-623	Approximate Shipping Weight Lbs (kg)
<b>72 kV Maximum (69 kV Nominal)</b>			
0.5	72DBA2-5	10, 12	15 (6.8)
3	72DBA2-3	10, 12	15 (6.8)
5E	72DBA2-5E	10, 12	15 (6.8)
7E	72DBA2-7E	10, 12	15 (6.8)
10E	72DBA2-10E	10, 12	15 (6.8)
15E	72DBA2-15E	10, 12	15 (6.8)
20E	72DBA2-20E	10, 12	15 (6.8)
25E	72DBA2-25E	10, 12	15 (6.8)
30E	72DBA2-30E	10, 12	15 (6.8)
40E	72DBA2-40E	10, 12	15 (6.8)
50E	72DBA2-50E	10, 12	15 (6.8)
65E	72DBA2-65E	10, 12	15 (6.8)
80E	72DBA2-80E	10, 12	15 (6.8)
100E	72DBA2-100E	10, 12	15 (6.8)
125E	72DBA2-125E	10, 12	15 (6.8)
150E	72DBA2-150E	10, 12	15 (6.8)
200E	72DBA2-200E	10, 12	15 (6.8)

Type DBA Expulsion Fuses for Use Indoors or Outdoors,  
continued

Ampere Rating	DBA-1 Fuse Units Catalog Number	Curve Reference 36-623	Approximate Shipping Weight Lbs (kg)
<b>Type DBA-2 Fuse Refills</b>			
<b>92 kV Maximum (92 kV Nominal)</b>			
3	92DBA2-3	10, 13	19 (8.6)
5E	92DBA2-5E	10, 13	19 (8.6)
7E	92DBA2-7E	10, 13	19 (8.6)
10E	92DBA2-10E	10, 13	19 (8.6)
15E	92DBA2-15E	10, 13	19 (8.6)
20E	92DBA2-20E	10, 13	19 (8.6)
25E	92DBA2-25E	10, 13	19 (8.6)
30E	92DBA2-30E	10, 13	19 (8.6)
40E	92DBA2-40E	10, 13	19 (8.6)
50E	92DBA2-50E	10, 13	19 (8.6)
65E	92DBA2-65E	10, 13	19 (8.6)
80E	92DBA2-80E	10, 13	19 (8.6)
100E	92DBA2-100E	10, 13	19 (8.6)
125E	92DBA2-125E	10, 13	19 (8.6)
150E	92DBA2-150E	10, 13	19 (8.6)
200E	92DBA2-200E	10, 13	19 (8.6)
<b>121 kV Maximum (115 kV Nominal)</b>			
3	121DBA2-3	10, 13	22 (10)
5E	121DBA2-5E	10, 13	22 (10)
7E	121DBA2-7E	10, 13	22 (10)
10E	121DBA2-10E	10, 13	22 (10)
15E	121DBA2-15E	10, 13	22 (10)
20E	121DBA2-20E	10, 13	22 (10)
25E	121DBA2-25E	10, 13	22 (10)
30E	121DBA2-30E	10, 13	22 (10)
40E	121DBA2-40E	10, 13	22 (10)
50E	121DBA2-50E	10, 13	22 (10)
65E	121DBA2-65E	10, 13	22 (10)
80E	121DBA2-80E	10, 13	22 (10)
100E	121DBA2-100E	10, 13	22 (10)
125E	121DBA2-125E	10, 13	22 (10)
150E	121DBA2-150E	10, 13	22 (10)
200E	121DBA2-200E	10, 13	22 (10)

Ampere Rating	DBA-1 Fuse Units Catalog Number	Curve Reference 36-623	Approximate Shipping Weight Lbs (kg)
<b>145 kV Maximum (138 kV Nominal)</b>			
3	145DBA2-3	10, 13	25 (11.4)
5E	145DBA2-5E	10, 13	25 (11.4)
7E	145DBA2-7E	10, 13	25 (11.4)
10E	145DBA2-10E	10, 13	25 (11.4)
15E	145DBA2-15E	10, 13	25 (11.4)
20E	145DBA2-20E	10, 13	25 (11.4)
25E	145DBA2-25E	10, 13	25 (11.4)
30E	145DBA2-30E	10, 13	25 (11.4)
40E	145DBA2-40E	10, 13	25 (11.4)
50E	145DBA2-50E	10, 13	25 (11.4)
65E	145DBA2-65E	10, 13	25 (11.4)
80E	145DBA2-80E	10, 13	25 (11.4)
100E	145DBA2-100E	10, 13	25 (11.4)
125E	145DBA2-125E	10, 13	25 (11.4)
150E	145DBA2-150E	10, 13	25 (11.4)
200E	145DBA2-200E	10, 13	25 (11.4)

### Contents

Description	Page
Product Selection . . . . .	V4-T26-96
Type CLE . . . . .	V4-T26-96
Type HLE . . . . .	V4-T26-100
Type BHLE . . . . .	V4-T26-103
Type HCL . . . . .	V4-T26-106
Type CLS . . . . .	V4-T26-108
Type CLPT . . . . .	V4-T26-114
Type CX . . . . .	V4-T26-119
Type CXN . . . . .	V4-T26-123
Type CXF . . . . .	V4-T26-125
Type DSL . . . . .	V4-T26-126

### Catalog Number Selection

#### Easy to Use, Easy to Order!

Eaton’s fuse catalog numbering system makes it easy to order the right fuse. The catalog numbers are easy to remember, unique to each fuse, and are broken down in three descriptive segments: Fuse type, voltage rating and current rating.

These catalog numbers can be entered directly and easily:

- No change in order processing will occur if you use either a style number or its corresponding catalog number. You will get the same fuse

#### Examples:

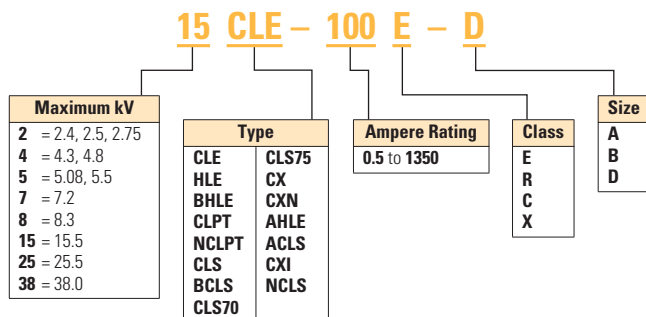
**5CLE-30E**—5.5 max. kV, CLE fuse unit, 30E amperes

**15CXN-45C**—15.5 max. kV, CXN fuse unit, 45C amperes

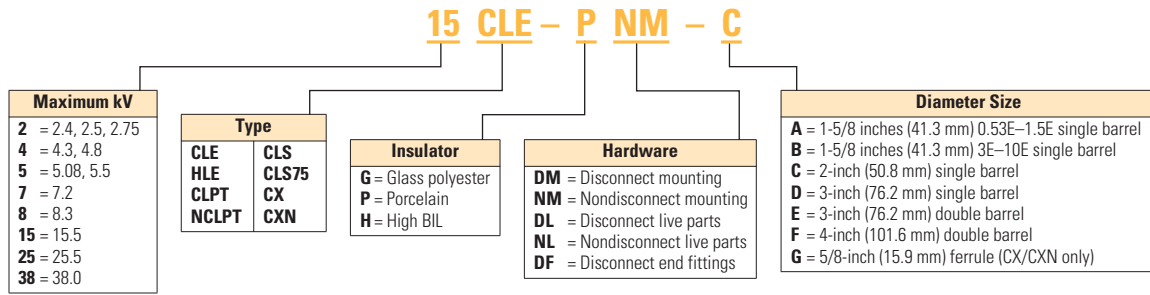
**5CLS-GDM-E**—5.5 max. kV, CLS fuse unit, glass polyester nondisconnect mounting

**CLE-DL-D**—CLE, disconnect live parts Size D

### Current Limiting Fuses



Current Limiting Fuse Accessories



#### Product Selection

#### Type CLE

26



#### Type CLE Current Limiting Fuses 2.75 kV Maximum (2.4 kV Nominal)

Current Rating (Amperes)	Barrel Number	Interrupting Rating rms (kA Sym.)	Heritage Product	Indoor/Outdoor	Performance Curves			Catalog Number
					Minimum Melting Time	Total Clearing Time	Peak Let-Through Current	
15E	1	50	H	Indoor	56353202	56353302	63931702	2CLE-15E
20E	1	50	H	Indoor	56353202	56353302	63931702	2CLE-20E
25E	1	50	H	Indoor	56353202	56353302	63931702	2CLE-25E
10E	1	50	H	Indoor	53686104	53686204	63931704	2CLE-10E
30E	1	50	H	Indoor	53686104	53686204	63931704	2CLE-30E
40E	1	50	H	Indoor	53686104	53686204	63931704	2CLE-40E
50E	1	50	H	Indoor	53686104	53686204	63931704	2CLE-50E
65E	1	50	H	Indoor	53686104	53686204	63931704	2CLE-65E
80E	1	50	H	Indoor	53686104	53686204	63931704	2CLE-80E
100E	1	50	H	Indoor	53686104	53686204	63931704	2CLE-100E
125E	1	50	H	Indoor	53686104	53686204	63931704	2CLE-125E
150E	1	50	H	Indoor	53686104	53686204	63931704	2CLE-150E
200E	1	50	H	Indoor	53686104	53686204	63931704	2CLE-200E
225E	1	50	H	Indoor	53686104	53686204	63931704	2CLE-225E
250E	2	50	H	Indoor	53690002	53690102	63931802	2CLE-250E
300E	2	50	H	Indoor	53690002	53690102	63931802	2CLE-300E
350X	2	50	H	Indoor	53690002	53690102	63931802	2CLE-350X
400X	2	50	H	Indoor	53690002	53690102	63931802	2CLE-400X
450X	2	50	H	Indoor	53690002	53690102	63931802	2CLE-450X

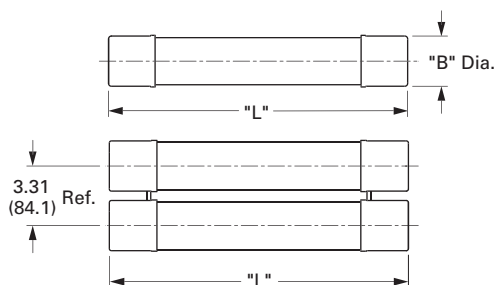
#### Type CLE Mountings and Hardware 2.75 kV Maximum (2.4 kV Nominal)

Ampere Rating	Fuse Mounting Type ①	Voltage BIL (kV)	Diameter	Clip Center	Length	Approximate Shipping Weight Lbs (kg)	Mounting (Including Live Parts, End Fittings) ②		Live Parts (Including End Fittings) ②	End Fittings (Disconnect Only)
							Porcelain Insulator Catalog Number	Glass-Polyester Insulator Catalog Number	Catalog Number	Catalog Number
15E–25E	Non-disconnect	60	2.00 (50.8)	8.13 (206.5)	9.50 (241.3)	2 (0.91)	2CLE-PNM-C	2CLE-GNM-C	CLE-NL-C	—
	Disconnect	60					2CLE-PDM-C	2CLE-GDM-C	CLE-DL-C	CLE-DF-C
10E–250E	Non-disconnect	60	3.00 (76.2)	7.00 (177.8)	10.90 (276.9)	7 (3.18)	2CLE-PNM-D	2CLE-GNM-D	CLE-NL-D	—
	Disconnect	60					2CLE-PDM-D	2CLE-GDM-D	CLE-DL-D	CLE-DF-D
300E–450E	Non-disconnect	60	3.00 (76.2)	7.00 (177.8)	10.90 (276.9)	15 (6.81)	2CLE-PNM-E	2CLE-GNM-E	CLE-NL-E	—
	Disconnect	60					2CLE-PDM-E	2CLE-GDM-E	CLE-DL-E	CLE-DF-E

#### Fuse Dimensional Details

Approximate Dimensions in Inches (mm)

#### Type CLE Fuse



CLE kV	"L"	"B" Dia.
15E–25E	9.50 (241.3)	2.00 (50.8)
10E–450E	10.90 (276.9)	3.00 (76.2)

#### Notes

- ① See Page V4-T26-127 for diagram of typical mounting.
- ② End fittings supplied only when required.



**Type CLE Current Limiting Fuses 5.5 kV Maximum (4.8 kV Nominal)**

Current Rating (Amperes)	Barrel Number	Interrupting Rating rms (kA Sym.)	Heritage Product	Indoor/Outdoor	Performance Curves			Catalog Number
					Minimum Melting Time	Total Clearing Time	Peak Let-Through Current	
15E	1	50	H	Indoor	56353204	56353304	63931702	5CLE-15E
20E	1	50	H	Indoor	56353204	56353304	63931702	5CLE-20E
25E	1	50	H	Indoor	56353204	56353304	63931702	5CLE-25E
10E	1	63	—	Indoor/outdoor	70548501	70548601	70548701	5CLE-10E-D
15E	1	63	—	Indoor/outdoor	70548501	70548601	70548701	5CLE-15E-D
20E	1	63	—	Indoor/outdoor	70548501	70548601	70548701	5CLE-20E-D
25E	1	63	—	Indoor/outdoor	70548501	70548601	70548701	5CLE-25E-D
30E	1	63	—	Indoor/outdoor	70548501	70548601	70548701	5CLE-30E
40E	1	50	—	Indoor/outdoor	70545801	70545901	70546701	5CLE-40E
50E	1	50	—	Indoor/outdoor	70545801	70545901	70546701	5CLE-50E
65E	1	50	—	Indoor/outdoor	70545801	70545901	70546701	5CLE-65E
80E	1	50	—	Indoor/outdoor	70545801	70545901	70546701	5CLE-80E
100E	1	50	—	Indoor/outdoor	70545801	70545901	70546701	5CLE-100E
125E	1	50	—	Indoor/outdoor	70545801	70545901	70546701	5CLE-125E
150E	1	63	—	Indoor/outdoor	70545801	70545901	70547601	5CLE-150E
175E	1	63	—	Indoor/outdoor	70545801	70545901	70547601	5CLE-175E
200E	1	63	—	Indoor/outdoor	70545801	70545901	70547601	5CLE-200E
250E	1	63	—	Indoor/outdoor	70545801	70545901	70547601	5CLE-250E
300E	2	63	—	Indoor/outdoor	70546001	70546101	70547601	5CLE-300E
350E	2	63	—	Indoor/outdoor	70546001	70546101	70547601	5CLE-350E
400E	2	63	—	Indoor/outdoor	70546001	70546101	70547601	5CLE-400E
450E	2	63	—	Indoor/outdoor	70546001	70546101	70547601	5CLE-450E
600E	2	40	—	Indoor	62908902	62908903	62908904	5CLE-600E
750E	2	40	—	Indoor	62908902	62908903	62908904	5CLE-750E
1100E	4	31	—	Indoor	62908902	62908903	62908904	5CLE-1100E
1350E	4	31	—	Indoor	62908902	62908903	62908904	5CLE-1350E

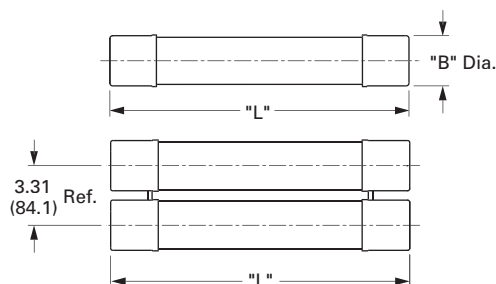
**Type CLE Mountings and Hardware 5.5 kV Maximum (4.8 kV Nominal)**

Ampere Rating	Fuse Mounting Type ①	Voltage BIL (kV)	Diameter	Clip Center	Length	Approximate Shipping Weight Lbs (kg)	Mounting (Including Live Parts, End Fittings) ②		Live Parts (Including End Fittings) ②	End Fittings (Disconnect Only)
							Porcelain Insulator Catalog Number	Glass-Polyester Insulator Catalog Number	Catalog Number	Catalog Number
10E-D–25E-D 30E–250E	Non-disconnect	60	3.00 (76.2)	14.00 (355.6)	17.90 (454.7)	9 (4.09)	5CLE-PNM-D	5CLE-GNM-D	CLE-NL-D	—
	Disconnect	60					5CLE-PDM-D	5CLE-GDM-D	CLE-DL-D	CLE-DF-D
15E–25E	Non-disconnect	60	2.00 (50.8)	11.50 (292.1)	12.90 (327.7)	3 (1.36)	5CLE-PNM-C	5CLE-GNM-C	CLE-NL-C	—
	Disconnect	60					5CLE-PDM-C	5CLE-GDM-C	CLE-DL-C	CLE-DF-C
300E–450E	Non-disconnect	60	3.00 (76.2)	14.00 (355.6)	17.90 (454.7)	19 (8.63)	5CLE-PNM-E	5CLE-GNM-E	CLE-NL-E	—
	Disconnect	60					5CLE-PDM-E	5CLE-GDM-E	CLE-DL-E	CLE-DF-E
600E and 750E	Consult factory	60	4.00 (101.6)	N/A	N/A	40 (18.16)	—	—	—	—
1100E and 1350E	Consult factory	—	4.00 (101.6)	N/A	N/A	80 (36.32)	—	—	—	—

**Fuse Dimensional Details**

Approximate Dimensions in Inches (mm)

**Type CLE Fuse**



CLE kV	"L"	"B" Dia.
15E–25E	12.90 (327.7)	2.00 (50.8)
10E–450E	17.90 (454.7)	3.00 (76.2)

**Notes**

- ① See Page V4-T26-127 for diagram of typical mounting.
- ② End fittings supplied only when required.



#### Type CLE Current Limiting Fuses 8.3 kV Maximum (7.2 kV Nominal)

Current Rating (Amperes)	Barrel Number	Interrupting Rating rms (kA Sym.)	Heritage Product	Indoor/Outdoor	Performance Curves			Catalog Number
					Minimum Melting Time	Total Clearing Time	Peak Let-Through Current	
15E	1	50	H	Indoor	56353204	56353304	63931703	8CLE-15E
20E	1	50	H	Indoor	56353204	56353304	63931703	8CLE-20E
25E	1	50	H	Indoor	56353204	56353304	63931703	8CLE-25E
10E	1	50	—	Indoor/outdoor	70548501	70548601	70548801	8CLE-10E-D
15E	1	50	—	Indoor/outdoor	70548501	70548601	70548801	8CLE-15E-D
20E	1	50	—	Indoor/outdoor	70548501	70548601	70548801	8CLE-20E-D
25E	1	50	—	Indoor/outdoor	70548501	70548601	70548801	8CLE-25E-D
30E	1	50	—	Indoor/outdoor	70548501	70548601	70548801	8CLE-30E
40E	1	50	—	Indoor/outdoor	70546201	70546301	70547301	8CLE-40E
50E	1	50	—	Indoor/outdoor	70546201	70546301	70547301	8CLE-50E
65E	1	50	—	Indoor/outdoor	70546201	70546301	70547301	8CLE-65E
80E	1	50	—	Indoor/outdoor	70546201	70546301	70547301	8CLE-80E
100E	1	50	—	Indoor/outdoor	70546201	70546301	70547301	8CLE-100E
125E	1	50	—	Indoor/outdoor	70546201	70546301	70547301	8CLE-125E
150E	1	50	—	Indoor/outdoor	70546201	70546301	70547301	8CLE-150E
175E	1	50	—	Indoor/outdoor	70546201	70546301	70547301	8CLE-175E
200E	2	50	—	Indoor/outdoor	70546401	70546501	70547301	8CLE-200E
250E	2	50	—	Indoor/outdoor	70546401	70546501	70547301	8CLE-250E
300E	2	50	—	Indoor/outdoor	70546401	70546501	70547301	8CLE-300E
350E	2	50	—	Indoor/outdoor	70546401	70546501	70547301	8CLE-350E

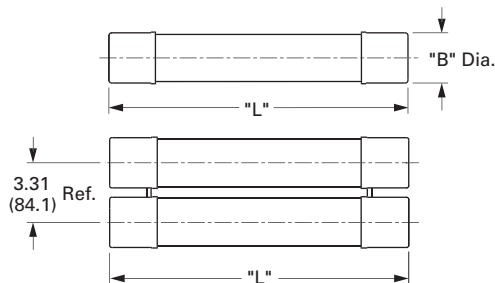
#### Type CLE Mountings and Hardware 8.3 kV Maximum (7.2 kV Nominal)

Ampere Rating	Fuse Mounting Type ①	Voltage BIL (kV)	Diameter	Clip Center	Length	Approximate Shipping Weight Lbs (kg)	Mounting (Including Live Parts, End Fittings) ②		Live Parts (Including End Fittings) ②	End Fittings (Disconnect Only)
							Porcelain Insulator Catalog Number	Glass-Polyester Insulator Catalog Number	Catalog Number	Catalog Number
15E-25E	Non-disconnect	75	2.00 (50.8)	14.00 (355.6)	15.50 (393.7)	3 (1.36)	8CLE-PNM-C	8CLE-GNM-C	CLE-NL-C	—
	Disconnect	75					8CLE-PDM-C	8CLE-GDM-C	CLE-DL-C	CLE-DF-C
10E-D-25E-D 30E-175E	Non-disconnect	75	3.00 (76.2)	14.00 (355.6)	17.90 (454.7)	9 (4.09)	8CLE-PNM-D	8CLE-GNM-D	CLE-NL-D	—
	Disconnect	75					8CLE-PDM-D	8CLE-GDM-D	CLE-DL-D	CLE-DF-D
200E-350E	Non-disconnect	75	3.00 (76.2)	14.00 (355.6)	17.90 (454.7)	19 (8.63)	8CLE-PNM-E	8CLE-GNM-E	CLE-NL-E	—
	Disconnect	75					8CLE-PDM-E	8CLE-GDM-E	CLE-DL-E	CLE-DF-E

#### Fuse Dimensional Details

Approximate Dimensions in Inches (mm)

#### Type CLE Fuse



CLE kV	"L"	"B" Dia.
15E-25E	15.50 (393.7)	2.00 (50.8)
10E-350E	17.90 (454.7)	3.00 (76.2)

#### Notes

- ① See Page V4-T26-127 for diagram of typical mounting.
- ② End fittings supplied only when required.



**Type CLE Current Limiting Fuses 15.5 kV Maximum (4.8 kV Nominal)**

Current Rating (Amperes)	Barrel Number	Interrupting Rating rms (kA Sym.)	Heritage Product	Indoor/Outdoor	Performance Curves			Catalog Number
					Minimum Melting Time	Total Clearing Time	Peak Let-Through Current	
15E	1	31.5	H	Indoor	56353204	56353304	63931703	15CLE-15E
20E	1	31.5	H	Indoor	56353204	56353304	63931703	15CLE-20E
25E	1	31.5	H	Indoor	56353204	56353304	63931703	15CLE-25E
10E	1	63	—	Indoor/outdoor	70548501	70548601	70548802	15CLE-10E-D
15E	1	63	—	Indoor/outdoor	70548501	70548601	70548802	15CLE-15E-D
20E	1	63	—	Indoor/outdoor	70548501	70548601	70548802	15CLE-20E-D
25E	1	63	—	Indoor/outdoor	70548501	70548601	70548802	15CLE-25E-D
30E	1	63	—	Indoor/outdoor	70548501	70548601	70548802	15CLE-30E
40E	1	63	—	Indoor/outdoor	70546801	70546901	70547501	15CLE-40E
50E	1	63	—	Indoor/outdoor	70546801	70546901	70547501	15CLE-50E
65E	1	63	—	Indoor/outdoor	70546801	70546901	70547501	15CLE-65E
80E	1	63	Ⓜ	Indoor/outdoor	70546801	70546901	70547501	15CLE-80E
100E	1	63	Ⓜ	Indoor/outdoor	70546801	70546901	70547501	15CLE-100E
125E	1	63	Ⓜ	Indoor/outdoor	70546801	70546901	70547501	15CLE-125E
150E	1	63	Ⓜ	Indoor/outdoor	70546801	70546901	70547501	15CLE-150E
175E	2	63	Ⓜ	Indoor/outdoor	70547001	70547101	70547501	15CLE-175E
200E	2	63	Ⓜ	Indoor/outdoor	70547001	70547101	70547501	15CLE-200E
250E	2	63	Ⓜ	Indoor/outdoor	70547001	70547101	70547501	15CLE-250E
300E	2	63	Ⓜ	Indoor/outdoor	70547001	70547101	70547501	15CLE-300E
80E	2	85	H Ⓜ	Indoor	59878302	59878402	63931604	15CLE2-80E
100E	2	85	H Ⓜ	Indoor	59878302	59878402	63931604	15CLE2-100E
125X	2	85	H Ⓜ	Indoor	59878302	59878402	63931604	15CLE2-125X
150E	3	50	H Ⓜ	Indoor	59878302	59878402	63931604	15CLE3-150E
175E/200X	3	50	H Ⓜ	Indoor	59878302	59878402	63931604	15CLE3-175E/200X

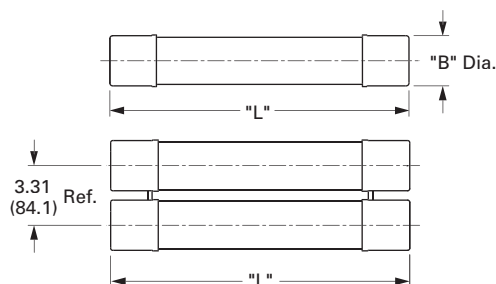
**Type CLE Mountings and Hardware 15.5 kV Maximum (4.8 kV Nominal)**

Ampere Rating	Fuse Mounting Type ①	Voltage BIL (kV)	Diameter	Clip Center	Length	Approximate Shipping Weight Lbs (kg)	Mounting (Including Live Parts, End Fittings) ②		Live Parts (Including End Fittings) ②	End Fittings (Disconnect Only)
							Porcelain Insulator Catalog Number	Glass-Polyester Insulator Catalog Number	Catalog Number	Catalog Number
15E-25E	Non-disconnect	95	2.00 (50.8)	20.00 (508.0)	21.50 (546.1)	4.5 (2.04)	15CLE-PNM-C	15CLE-GNM-C	CLE-NL-D	—
		110					15CLE-HPNM-C	—	—	—
	Disconnect	95	15CLE-PDM-C	15CLE-GDM-C	CLE-DL-C	CLE-DF-C				
		110	15CLE-HPDM-C	—	—	—				
10E-D-25E-D 30E-150E	Non-disconnect	95	3.00 (76.2)	20.00 (508.0)	23.90 (607.1)	11 (4.99)	15CLE-PNM-D	15CLE-GNM-D	CLE-NL-D	—
		110					15CLE-HPM-D	—	—	—
	Disconnect	95	15CLE-PDM-D	15CLE-GNM-D	CLE-DL-D	CLE-DF-D				
		110	15CLE-HPDM-D	—	—	—				
175E-300E	Non-disconnect	110	3.00 (76.2)	20.00 (508.0)	23.90 (607.1)	23 (10.44)	15CLE-PNM-E	—	CLE-DL-E	CLE-DF-E
	Disconnect	110					15CLE-PDM-E	—	—	—

**Fuse Dimensional Details**

Approximate Dimensions in Inches (mm)

**Type CLE Fuse**



CLE kV	"L"	"B" Dia.
15E-25E	21.50 (546.1)	2.00 (50.8)
10E-300E	23.90 (607.1)	3.00 (76.2)

**Notes**

- ① See Page V4-T26-127 for diagram of typical mounting.
- ② For mountings, consult factory.
- ③ End fittings supplied only when required.



#### Type HLE

#### Type HLE Current Limiting Fuses 5.5 kV Maximum (4.8 kV Nominal) Interrupting Rating 63 (kA rms Sym.)

Current Rating (Amperes)	Barrel Number	Indoor/Outdoor	Performance Curves			Catalog Number	Bolt-In Ferrule Catalog Number	AMPGARD Catalog Number
			Minimum Melting Time	Total Clearing Time	Peak Let-Through Current			
10E	1	Indoor/outdoor	70548507	70548607	70548703	5HLE-10E	5BHLE-10E	5AHLE-10E
15E	1	Indoor/outdoor	70548507	70548607	70548703	5HLE-15E	5BHLE-15E	5AHLE-15E
20E	1	Indoor/outdoor	70548507	70548607	70548703	5HLE-20E	5BHLE-20E	5AHLE-20E
25E	1	Indoor/outdoor	70548507	70548607	70548703	5HLE-25E	5BHLE-25E	5AHLE-25E
30E	1	Indoor/outdoor	70548507	70548607	70548703	5HLE-30E	5BHLE-30E	5AHLE-30E
40E	1	Indoor/outdoor	70545805	70545905	70547603	5HLE-40E	5BHLE-40E	5AHLE-40E
50E	1	Indoor/outdoor	70545805	70545905	70547603	5HLE-50E	5BHLE-50E	5AHLE-50E
65E	1	Indoor/outdoor	70545805	70545905	70547603	5HLE-65E	5BHLE-65E	5AHLE-65E
80E	1	Indoor/outdoor	70545805	70545905	70547603	5HLE-80E	5BHLE-80E	5AHLE-80E
100E	1	Indoor/outdoor	70545805	70545905	70547603	5HLE-100E	5BHLE-100E	5AHLE-100E
125E	1	Indoor/outdoor	70545805	70545905	70547603	5HLE-125E	5BHLE-125E	5AHLE-125E
150E	1	Indoor/outdoor	70545805	70545905	70547603	5HLE-150E	5BHLE-150E	5AHLE-150E
175E	1	Indoor/outdoor	70545805	70545905	70547603	5HLE-175E	5BHLE-175E	5AHLE-175E
200E	1	Indoor/outdoor	70545805	70545905	70547603	5HLE-200E	5BHLE-200E	5AHLE-200E
250E	1	Indoor/outdoor	70545805	70545905	70547603	5HLE-250E	5BHLE-250E	5AHLE-250E
300E	2	Indoor/outdoor	70546005	70546105	70547603	5HLE-300E	5BHLE-300E	5AHLE-300E
350E	2	Indoor/outdoor	70546005	70546105	70547603	5HLE-350E	5BHLE-350E	5AHLE-350E
400E	2	Indoor/outdoor	70546005	70546105	70547603	5HLE-400E	5BHLE-400E	5AHLE-400E
450E	2	Indoor/outdoor	70546005	70546105	70547603	5HLE-450E	5BHLE-450E	5AHLE-450E

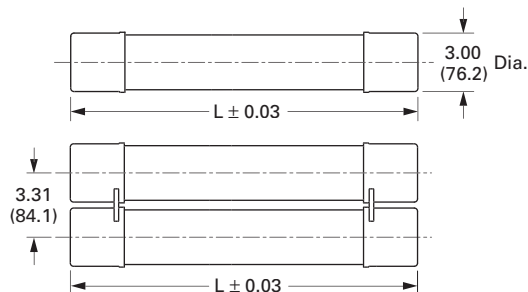
#### Type HLE Mountings and Hardware 5.5 kV Maximum (4.8 kV Nominal)

Ampere Rating	Fuse Mounting Type ①	Voltage BIL (kV)	Diameter	Clip Center	Length	Approximate Shipping Weight Lbs (kg)	Mounting (Including Live Parts, End Fittings) ②		Live Parts (Including End Fittings) ②	End Fittings (Disconnect Only)
							Porcelain Insulator Catalog Number	Glass-Polyester Insulator Catalog Number	Catalog Number	Catalog Number
10E–250E	Non-disconnect	60	3.00 (76.2)	12.00 (304.8)	15.90 (403.9)	8 (3.63)	5HLE-PNM-D	5HLE-GNM-D	CLE-NL-D	—
	Disconnect	60					5HLE-PDM-D	5HLE-GDM-D	CLE-DL-D	CLE-DF-D
300E–450E	Non-disconnect	60	3.00 (76.2)	12.00 (304.8)	15.90 (403.9)	17 (7.72)	5HLE-PNM-E	5HLE-GNM-E	CLE-NL-E	—
	Disconnect	60					5HLE-PDM-E	5HLE-GDM-E	CLE-DL-E	CLE-DF-D

#### Fuse Dimensional Details

Approximate Dimensions in Inches (mm)

#### Type HLE Fuse



HLE kV	L ± 0.03
5.5	15.88 (403.4)

#### Notes

- ① See Page V4-T26-127 for diagram of typical mounting.
- ② End fittings supplied only when required.



**Type HLE Current Limiting Fuses 8.3 kV Maximum (7.2 kV Nominal) Interrupting Rating 50 (kA Sym.)**

Current Rating (Amperes)	Barrel Number	Indoor/Outdoor	Performance Curves			Catalog Number	Bolt-In Ferrule Catalog Number	AMPGARD Catalog Number
			Minimum Melting Time	Total Clearing Time	Peak Let-Through Current			
10E	1	Indoor/outdoor	70548507	70548607	70548804	8HLE-10E	8BHLE-10E	8AHLE-10E
15E	1	Indoor/outdoor	70548507	70548607	70548804	8HLE-15E	8BHLE-15E	8AHLE-15E
20E	1	Indoor/outdoor	70548507	70548607	70548804	8HLE-20E	8BHLE-20E	8AHLE-20E
25E	1	Indoor/outdoor	70548507	70548607	70548804	8HLE-25E	8BHLE-25E	8AHLE-25E
30E	1	Indoor/outdoor	70548507	70548607	70548804	8HLE-30E	8BHLE-30E	8AHLE-30E
40E	1	Indoor/outdoor	70546203	70546303	70547201	8HLE-40E	8BHLE-40E	8AHLE-40E
50E	1	Indoor/outdoor	70546203	70546303	70547201	8HLE-50E	8BHLE-50E	8AHLE-50E
65E	1	Indoor/outdoor	70546203	70546303	70547201	8HLE-65E	8BHLE-65E	8AHLE-65E
80E	1	Indoor/outdoor	70546203	70546303	70547201	8HLE-80E	8BHLE-80E	8AHLE-80E
100E	1	Indoor/outdoor	70546203	70546303	70547201	8HLE-100E	8BHLE-100E	8AHLE-100E
125E	1	Indoor/outdoor	70546203	70546303	70547201	8HLE-125E	8BHLE-125E	8AHLE-125E
150E	1	Indoor/outdoor	70546203	70546303	70547201	8HLE-150E	8BHLE-150E	8AHLE-150E
175E	1	Indoor/outdoor	70546203	70546303	70547201	8HLE-175E	8BHLE-175E	8AHLE-175E
200E	2	Indoor/outdoor	70546403	70546503	70547201	8HLE-200E	8BHLE-200E	8AHLE-200E
250E	2	Indoor/outdoor	70546403	70546503	70547201	8HLE-250E	8BHLE-250E	8AHLE-250E
300E	2	Indoor/outdoor	70546403	70546503	70547201	8HLE-300E	8BHLE-300E	8AHLE-300E
350E	2	Indoor/outdoor	70546403	70546503	70547201	8HLE-350E	8BHLE-350E	8AHLE-350E

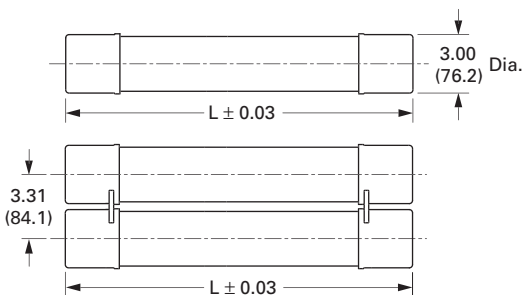
**Type HLE Mountings and Hardware 8.3 kV Maximum (7.2 kV Nominal)**

Ampere Rating	Fuse Mounting Type ①	Voltage BIL (kV)	Diameter	Clip Center	Length	Approximate Shipping Weight Lbs (kg)	Mounting (Including Live Parts, End Fittings) ②		Live Parts (Including End Fittings) ②	End Fittings (Disconnect Only)
							Porcelain Insulator Catalog Number	Glass-Polyester Insulator Catalog Number	Catalog Number	Catalog Number
10E–175E	Non-disconnect	75	3.00 (76.2)	12.00 (304.8)	15.90 (403.9)	8 (3.63)	8HLE-PNM-D	8HLE-GNM-D	CLE-NL-D	—
	Disconnect	75					8HLE-PDM-D	8HLE-GDM-D	CLE-DL-D	CLE-DF-D
200E–350E	Non-disconnect	75					8HLE-PNM-E	8HLE-GNM-E	CLE-NL-E	—
	Disconnect	75					8HLE-PDM-E	8HLE-GDM-E	CLE-DL-E	CLE-DF-E

**Fuse Dimensional Details**

Approximate Dimensions in Inches (mm)

**Type HLE Fuse**



HLE kV	L ± 0.03
8.3	15.88 (403.4)

**Notes**

- ① See Page V4-T26-127 for diagram of typical mounting.
- ② End fittings supplied only when required.



#### Type HLE Current Limiting Fuses 15.5 kV Maximum (14.4 kV Nominal)

Current Rating (Amperes)	Barrel Number	Interrupting Rating rms (kA Sym.)	Indoor/Outdoor	Performance Curves			Catalog Number	Bolt-In Ferrule Catalog Number
				Minimum Melting Time	Total Clearing Time	Peak Let-Through Current		
10E	1	63	Indoor/outdoor	70548507	70548607	70548805	15HLE-10E	15BHLE-10E
15E	1	63	Indoor/outdoor	70548507	70548607	70548805	15HLE-15E	15BHLE-15E
20E	1	63	Indoor/outdoor	70548507	70548607	70548805	15HLE-20E	15BHLE-20E
25E	1	63	Indoor/outdoor	70548507	70548607	70548805	15HLE-25E	15BHLE-25E
30E	1	63	Indoor/outdoor	70548507	70548607	70548805	15HLE-30E	15BHLE-30E
40E	1	63	Indoor/outdoor	70546601	70546701	70547401	15HLE-40E	15BHLE-40E
50E	1	63	Indoor/outdoor	70546601	70546701	70547401	15HLE-50E	15BHLE-50E
65E	1	63	Indoor/outdoor	70546601	70546701	70547401	15HLE-65E	15BHLE-65E
80E	1	63	Indoor/outdoor	70546601	70546701	70547401	15HLE-80E	15BHLE-80E
100E	1	63	Indoor/outdoor	70546601	70546701	70547401	15HLE-100E	15BHLE-100E
125E	1	63	Indoor/outdoor	70546601	70546701	70547401	15HLE-125E	15BHLE-125E
150E	2	63	Indoor/outdoor	70546601	70546701	70547401	15HLE-150E	15BHLE-150E
175E	2	63	Indoor/outdoor	70546601	70546701	70547401	15HLE-175E	15BHLE-175E
200E	2	63	Indoor/outdoor	70546601	70546701	70547401	15HLE-200E	15BHLE-200E
250E	2	63	Indoor/outdoor	70546601	70546701	70547401	15HLE-250E	15BHLE-250E

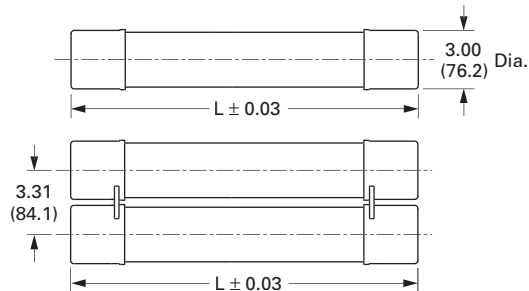
#### Type HLE Mountings and Hardware 15.5 kV Maximum (14.4 kV Nominal)

Ampere Rating	Fuse Mounting Type ①	Voltage BIL (kV)	Diameter	Clip Center	Length	Approximate Shipping Weight Lbs (kg)	Mounting (Including Live Parts, End Fittings) ②		Live Parts (Including End Fittings) ②	End Fittings (Disconnect Only)
							Porcelain Insulator Catalog Number	Glass-Polyester Insulator Catalog Number	Catalog Number	Catalog Number
10E–175E	Non-disconnect	95	3.00 (76.2)	15.00 (381.0)	18.90 (480.1)	10 (4.54)	15HLE-PNM-D	15HLE-GNM-D	CLE-NL-D	—
	Disconnect	95					15HLE-PDM-D	15HLE-GDM-D	CLE-DL-D	CLE-DF-D
150E–250E	Non-disconnect	95	3.00 (76.2)	15.00 (381.0)	18.90 (480.1)	21 (9.53)	15HLE-PNM-E	—	CLE-NL-E	—
	Disconnect	95					15HLE-PDM-E	—	CLE-DL-E	CLE-DF-E

#### Fuse Dimensional Details

Approximate Dimensions in Inches (mm)

#### Type HLE Fuse



HLE kV	L ± 0.03
15.5	18.88 (479.6)

#### Notes

- ① See Page V4-T26-127 for diagram of typical mounting.
- ② End fittings supplied only when required.

**Type BHLE**

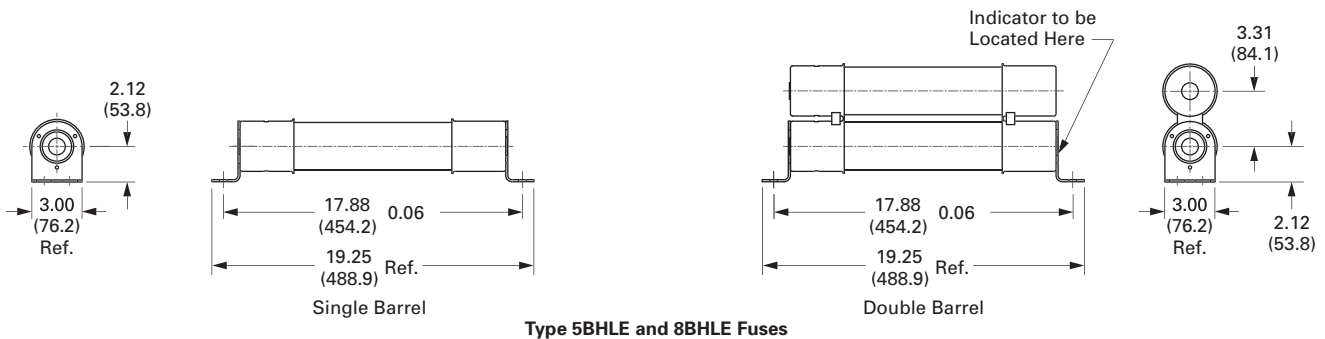
Approximate Dimensions in Inches (mm)

**Type BHLE Current Limiting Fuses 5.5 kV Maximum (4.8 kV Nominal), Indoor, Bolt-In**

Current Rating (Amperes)	Barrel Number	Interrupting Rating rms (kA Sym.)	Diameter	Length	Approximate Shipping Weight Lbs (kg)	Performance Curves			Catalog Number
						Minimum Melting Time	Total Clearing Time	Peak Let-Through Current	
10E	1	63	3.00 (76.2)	15.90 (403.9)	8 (3.63)	70548507	70548607	70548703	<b>5BHLE-10E</b>
15E	1	63	3.00 (76.2)	15.90 (403.9)	8 (3.63)	70548507	70548607	70548703	<b>5BHLE-15E</b>
20E	1	63	3.00 (76.2)	15.90 (403.9)	8 (3.63)	70548507	70548607	70548703	<b>5BHLE-20E</b>
25E	1	63	3.00 (76.2)	15.90 (403.9)	8 (3.63)	70548507	70548607	70548703	<b>5BHLE-25E</b>
30E	1	63	3.00 (76.2)	15.90 (403.9)	8 (3.63)	70548507	70548607	70548703	<b>5BHLE-30E</b>
40E	1	63	3.00 (76.2)	15.90 (403.9)	8 (3.63)	70545805	70545905	70547603	<b>5BHLE-40E</b>
50E	1	63	3.00 (76.2)	15.90 (403.9)	8 (3.63)	70545805	70545905	70547603	<b>5BHLE-50E</b>
65E	1	63	3.00 (76.2)	15.90 (403.9)	8 (3.63)	70545805	70545905	70547603	<b>5BHLE-65E</b>
80E	1	63	3.00 (76.2)	15.90 (403.9)	8 (3.63)	70545805	70545905	70547603	<b>5BHLE-80E</b>
100E	1	63	3.00 (76.2)	15.90 (403.9)	8 (3.63)	70545805	70545905	70547603	<b>5BHLE-100E</b>
125E	1	63	3.00 (76.2)	15.90 (403.9)	8 (3.63)	70545805	70545905	70547603	<b>5BHLE-125E</b>
150E	1	63	3.00 (76.2)	15.90 (403.9)	8 (3.63)	70545805	70545905	70547603	<b>5BHLE-150E</b>
175E	1	63	3.00 (76.2)	15.90 (403.9)	8 (3.63)	70545805	70545905	70547603	<b>5BHLE-175E</b>
200E	1	63	3.00 (76.2)	15.90 (403.9)	8 (3.63)	70545805	70545905	70547603	<b>5BHLE-200E</b>
250E	1	63	3.00 (76.2)	15.90 (403.9)	8 (3.63)	70545805	70545905	70547603	<b>5BHLE-250E</b>
300E	2	63	3.00 (76.2)	15.90 (403.9)	17 (7.72)	70546005	70546105	70547603	<b>5BHLE-300E</b>
350E	2	63	3.00 (76.2)	15.90 (403.9)	17 (7.72)	70546005	70546105	70547603	<b>5BHLE-350E</b>
400E	2	63	3.00 (76.2)	15.90 (403.9)	17 (7.72)	70546005	70546105	70547603	<b>5BHLE-400E</b>
450E	2	63	3.00 (76.2)	15.90 (403.9)	17 (7.72)	70546005	70546105	70547603	<b>5BHLE-450E</b>

**Fuse Dimensional Details**

**Type BHLE Fuse**



# 26.5

## Power Breakers, Contactors and Fuses

### Current Limiting Fuses

Approximate Dimensions in Inches (mm)

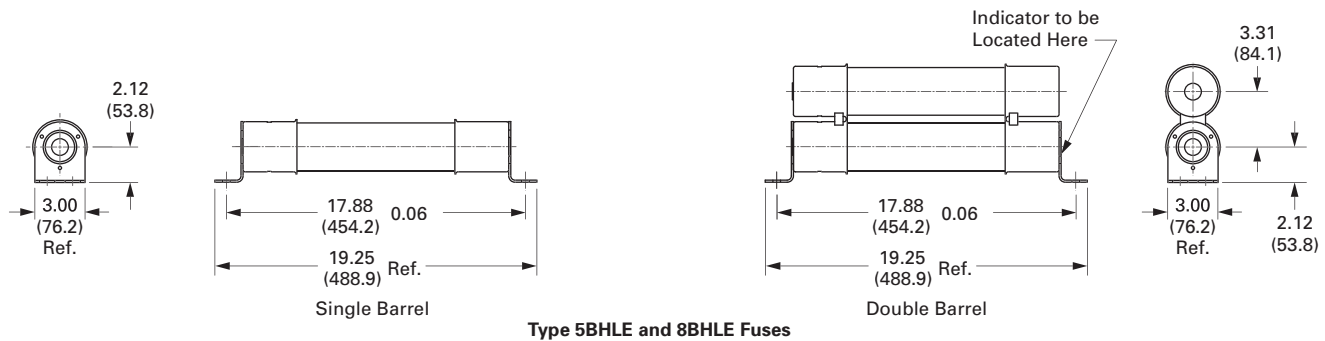
#### Type BHLE Current Limiting Fuses 8.3 kV Maximum (7.2 kV Nominal), Indoor, Bolt-In

26

Current Rating (Amperes)	Barrel Number	Interrupting Rating rms (kA Sym.)	Diameter	Length	Approximate Shipping Weight Lbs (kg)	Performance Curves			Catalog Number
						Minimum Melting Time	Total Clearing Time	Peak Let-Through Current	
10E	1	50	3.00 (76.2)	15.90 (403.9)	8 (3.63)	70548507	70548607	70548804	8BHLE-10E
15E	1	50	3.00 (76.2)	15.90 (403.9)	8 (3.63)	70548507	70548607	70548804	8BHLE-15E
20E	1	50	3.00 (76.2)	15.90 (403.9)	8 (3.63)	70548507	70548607	70548804	8BHLE-20E
25E	1	50	3.00 (76.2)	15.90 (403.9)	8 (3.63)	70548507	70548607	70548804	8BHLE-25E
30E	1	50	3.00 (76.2)	15.90 (403.9)	8 (3.63)	70548507	70548607	70548804	8BHLE-30E
40E	1	50	3.00 (76.2)	15.90 (403.9)	8 (3.63)	70546203	70546303	70547201	8BHLE-40E
50E	1	50	3.00 (76.2)	15.90 (403.9)	8 (3.63)	70546203	70546303	70547201	8BHLE-50E
65E	1	50	3.00 (76.2)	15.90 (403.9)	8 (3.63)	70546203	70546303	70547201	8BHLE-65E
80E	1	50	3.00 (76.2)	15.90 (403.9)	8 (3.63)	70546203	70546303	70547201	8BHLE-80E
100E	1	50	3.00 (76.2)	15.90 (403.9)	8 (3.63)	70546203	70546303	70547201	8BHLE-100E
125E	1	50	3.00 (76.2)	15.90 (403.9)	8 (3.63)	70546203	70546303	70547201	8BHLE-125E
150E	1	50	3.00 (76.2)	15.90 (403.9)	8 (3.63)	70546203	70546303	70547201	8BHLE-150E
175E	1	50	3.00 (76.2)	15.90 (403.9)	8 (3.63)	70546203	70546303	70547201	8BHLE-175E
200E	2	50	3.00 (76.2)	15.90 (403.9)	17 (7.72)	70546403	70546503	70547201	8BHLE-200E
250E	2	50	3.00 (76.2)	15.90 (403.9)	17 (7.72)	70546403	70546503	70547201	8BHLE-250E
300E	2	50	3.00 (76.2)	15.90 (403.9)	17 (7.72)	70546403	70546503	70547201	8BHLE-300E
350E	2	50	3.00 (76.2)	15.90 (403.9)	17 (7.72)	70546403	70546503	70547201	8BHLE-350E

#### Fuse Dimensional Details

##### Type BHLE Fuse



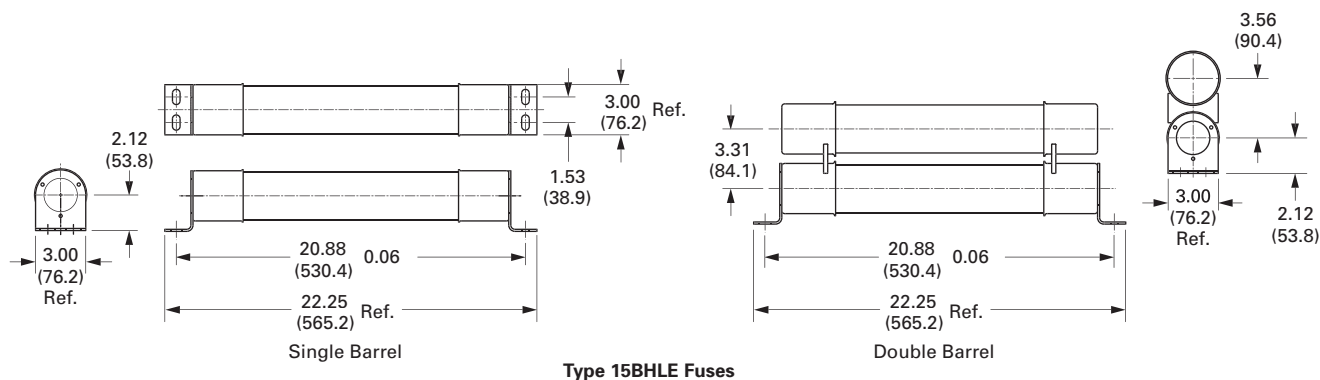
Approximate Dimensions in Inches (mm)

**Type BHLE Current Limiting Fuses 15.5 kV Maximum (14.4 kV Nominal), Indoor/Outdoor, Bolt-In**

Current Rating (Amperes)	Barrel Number	Interrupting Rating rms (kA Sym.)	Diameter	Length	Approximate Shipping Weight Lbs (kg)	Performance Curves			Catalog Number
						Minimum Melting Time	Total Clearing Time	Peak Let-Through Current	
10E	1	63	3.00 (76.2)	18.90 (480.1)	10 (4.54)	70548507	70548607	70548805	15BHLE-10E
15E	1	63	3.00 (76.2)	18.90 (480.1)	10 (4.54)	70548507	70548607	70548805	15BHLE-15E
20E	1	63	3.00 (76.2)	18.90 (480.1)	10 (4.54)	70548507	70548607	70548805	15BHLE-20E
25E	1	63	3.00 (76.2)	18.90 (480.1)	10 (4.54)	70548507	70548607	70548805	15BHLE-25E
30E	1	63	3.00 (76.2)	18.90 (480.1)	10 (4.54)	70548507	70548607	70548805	15BHLE-30E
40E	1	63	3.00 (76.2)	18.90 (480.1)	10 (4.54)	70546601	70546701	70547401	15BHLE-40E
50E	1	63	3.00 (76.2)	18.90 (480.1)	10 (4.54)	70546601	70546701	70547401	15BHLE-50E
65E	1	63	3.00 (76.2)	18.90 (480.1)	10 (4.54)	70546601	70546701	70547401	15BHLE-65E
80E	1	63	3.00 (76.2)	18.90 (480.1)	10 (4.54)	70546601	70546701	70547401	15BHLE-80E
100E	1	63	3.00 (76.2)	18.90 (480.1)	10 (4.54)	70546601	70546701	70547401	15BHLE-100E
125E	1	63	3.00 (76.2)	18.90 (480.1)	10 (4.54)	70546601	70546701	70547401	15BHLE-125E
150E	2	63	3.00 (76.2)	18.90 (480.1)	21 (9.53)	70546601	70546701	70547401	15BHLE-150E
175E	2	63	3.00 (76.2)	18.90 (480.1)	21 (9.53)	70546601	70546701	70547401	15BHLE-175E
200E	2	63	3.00 (76.2)	18.90 (480.1)	21 (9.53)	70546601	70546701	70547401	15BHLE-200E
250E	2	63	3.00 (76.2)	18.90 (480.1)	21 (9.53)	70546601	70546701	70547401	15BHLE-250E

**Fuse Dimensional Details**

**Type BHLE Fuse**



## Type HCL

## Type HCL Current Limiting Fuses 5.5 kV Maximum (4.8 kV Nominal), Indoor

Current Rating (Amperes)	Barrel Number	Interrupting Rating rms (kA Sym.)	Diameter	Clip Center	Approximate Shipping Weight Lbs (kg)	Mounting Type	Live Parts (Includes End Fittings) Catalog Number	Performance Curves			Catalog Number
								Minimum Melting Time	Total Clearing Time	Peak Let-Through Current	
10E	1	63	3.00 (76.2)	Clip-lock	9 (4.09)	Non-disconnect	HCL-NL-1	70548505	70548605	70548702	5HCL-10E
15E	1	63	3.00 (76.2)	Clip-lock	9 (4.09)	Non-disconnect	HCL-NL-1	70548505	70548605	70548702	5HCL-15E
20E	1	63	3.00 (76.2)	Clip-lock	9 (4.09)	Non-disconnect	HCL-NL-1	70548505	70548605	70548702	5HCL-20E
25E	1	63	3.00 (76.2)	Clip-lock	9 (4.09)	Non-disconnect	HCL-NL-1	70548505	70548605	70548702	5HCL-25E
30E	1	63	3.00 (76.2)	Clip-lock	9 (4.09)	Non-disconnect	HCL-NL-1	70548505	70548605	70548702	5HCL-30E
40E	1	63	3.00 (76.2)	Clip-lock	9 (4.09)	Non-disconnect	HCL-NL-1	70545803	70545903	70547602	5HCL-40E
50E	1	63	3.00 (76.2)	Clip-lock	9 (4.09)	Non-disconnect	HCL-NL-1	70545803	70545903	70547602	5HCL-50E
65E	1	63	3.00 (76.2)	Clip-lock	9 (4.09)	Non-disconnect	HCL-NL-1	70545803	70545903	70547602	5HCL-65E
80E	1	63	3.00 (76.2)	Clip-lock	9 (4.09)	Non-disconnect	HCL-NL-1	70545803	70545903	70547602	5HCL-80E
100E	1	63	3.00 (76.2)	Clip-lock	9 (4.09)	Non-disconnect	HCL-NL-1	70545803	70545903	70547602	5HCL-100E
125E	1	63	3.00 (76.2)	Clip-lock	9 (4.09)	Non-disconnect	HCL-NL-1	70545803	70545903	70547602	5HCL-125E
150E	1	63	3.00 (76.2)	Clip-lock	9 (4.09)	Non-disconnect	HCL-NL-1	70545803	70545903	70547602	5HCL-150E
200E	1	63	3.00 (76.2)	Clip-lock	10 (4.54)	Non-disconnect	HCL-NL-1	70545803	70545903	70547602	5HCL-200E
250E	1	63	3.00 (76.2)	Clip-lock	10 (4.54)	Non-disconnect	HCL-NL-1	70545803	70545903	70547602	5HCL-250E
300E	2	63	3.00 (76.2)	Clip-lock	20 (9.08)	Non-disconnect	HCL-NL-1	70546003	70516103	70547602	5HCL-300E
400E	2	63	3.00 (76.2)	Clip-lock	20 (9.08)	Non-disconnect	HCL-NL-1	70546003	70516103	70547602	5HCL-400E
450E	2	63	3.00 (76.2)	Clip-lock	20 (9.08)	Non-disconnect	HCL-NL-1	70546003	70516103	70547602	5HCL-450E
500E	2	63	3.00 (76.2)	Clip-lock	20 (9.08)	Non-disconnect	HCL-NL-1	66703401	66703501	66703701	5HCL-500E
600E	2	63	3.00 (76.2)	Clip-lock	20 (9.08)	Non-disconnect	HCL-NL-1	66703401	66703501	66703701	5HCL-600E
750E	3	63	3.00 (76.2)	Bolt-in	30 (13.62)	—	—	66703401	66703501	66703701	5HCL-750E
	3	63	3.00 (76.2)	Bolt-in	30 (13.62)	—	—	66703401	66703501	66703701	5BHCL-750E
900E	3	63	3.00 (76.2)	Bolt-in	30 (13.62)	—	—	66703401	66703501	66703701	5HCL-900E
	3	63	3.00 (76.2)	Bolt-in	30 (13.62)	—	—	66703401	66703501	66703701	5BHCL-900E

## Type HCL Current Limiting Fuses (15.5 kV Maximum, 14.4 kV Nominal), Indoor

Current Rating (Amperes)	Barrel Number	Interrupting Rating rms (kA Sym.)	Diameter	Clip Center	Approximate Shipping Weight Lbs (kg)	Mounting Type	Live Parts (Includes End Fittings) Catalog Number	Performance Curves			Catalog Number
								Minimum Melting Time	Total Clearing Time	Peak Let-Through Current	
10E	1	63	3.00 (76.2)	Clip-lock	10 (4.54)	Non-disconnect	HCL-NL-1	70548503	70548603	70548803	15HCL-10E
15E	1	63	3.00 (76.2)	Clip-lock	10 (4.54)	Non-disconnect	HCL-NL-1	70548503	70548603	70548803	15HCL-15E
20E	1	63	3.00 (76.2)	Clip-lock	10 (4.54)	Non-disconnect	HCL-NL-1	70548503	70548603	70548803	15HCL-20E
25E	1	63	3.00 (76.2)	Clip-lock	10 (4.54)	Non-disconnect	HCL-NL-1	70548503	70548603	70548803	15HCL-25E
30E	1	63	3.00 (76.2)	Clip-lock	10 (4.54)	Non-disconnect	HCL-NL-1	70548503	70548603	70548803	15HCL-30E
40E	1	63	3.00 (76.2)	Clip-lock	10 (4.54)	Non-disconnect	HCL-NL-1	66703201	66703301	70547402	15HCL-40E
50E	1	63	3.00 (76.2)	Clip-lock	10 (4.54)	Non-disconnect	HCL-NL-1	66703201	66703301	70547402	15HCL-50E
65E	1	50	3.00 (76.2)	Clip-lock	12 (5.45)	Non-disconnect	HCL-NL-1	66703201	66703301	70547402	15HCL-65E
80E	1	50	3.00 (76.2)	Clip-lock	12 (5.45)	Non-disconnect	HCL-NL-1	66703201	66703301	70547402	15HCL-80E
100E	1	50	3.00 (76.2)	Clip-lock	12 (5.45)	Non-disconnect	HCL-NL-1	66703201	66703301	70547402	15HCL-100E
125E	1	50	3.00 (76.2)	Clip-lock	12 (5.45)	Non-disconnect	HCL-NL-1	66703201	66703301	70547402	15HCL-125E
150E	2	50	3.00 (76.2)	Clip-lock	24 (10.90)	Non-disconnect	HCL-NL-1	66703201	66703301	70547402	15HCL-150E
200E	2	50	3.00 (76.2)	Clip-lock	24 (10.90)	Non-disconnect	HCL-NL-1	66703201	66703301	70547402	15HCL-200E
250E	2	50	3.00 (76.2)	Clip-lock	24 (10.90)	Non-disconnect	HCL-NL-1	66703201	66703301	70547402	15HCL-250E
300E	2	50	3.00 (76.2)	Clip-lock	24 (10.90)	Non-disconnect	HCL-NL-1	66703201	66703301	70547402	15HCL-300E

**Note**

Approximate Dimensions in Inches (mm).

**Fuse Dimensional Details**

Approximate Dimensions in Inches (mm)

**5.5 and 15.5 kV Clip Lock Mounted**

Ampere Rating	Number of Barrels	Figure Number	A	B	C	Interrupting Rating rms (kA Sym.)
<b>5.5 kV Maximum—Clip Lock Style—15.25-Inch (387.4 mm) Clip Centers—3.00-Inch (76.2 mm) Barrel Diameter</b>						
10E–150E	1	A	16.81 (427.0)	16.12 (409.4)	①	63
<b>5.5 kV Maximum—Clip Lock Style—21.25-Inch (539.8 mm) Clip Centers—3.00-Inch (76.2 mm) Barrel Diameter</b>						
200E–600E	1	A	22.81 (579.4)	22.12 (561.8)	①	63

**15.5 kV Clip Lock Mounted**

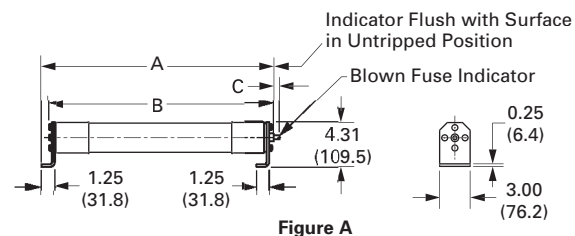
Ampere Rating	Number of Barrels	Figure Number	A	B	C	Interrupting Rating rms (kA Sym.)
<b>15.5 kV Maximum—Clip Lock Style—21.25-Inch (539.8 mm) Clip Centers—3.00-Inch (76.2 mm) Barrel Diameter</b>						
65E–125E	1	A	22.81 (579.4)	22.12 (561.8)	①	63
150E–300E	2	B	22.81 (579.4)	22.12 (561.8)	①	50
<b>15.5 kV Maximum—Clip Lock Style—18.25-Inch (463.6 mm) Clip Centers—3.00-Inch (76.2 mm) Barrel Diameter</b>						
10E–50E	1	A	19.81 (503.2)	19.12 (485.6)	①	63

**Bolt-In Series—5.5 kV**

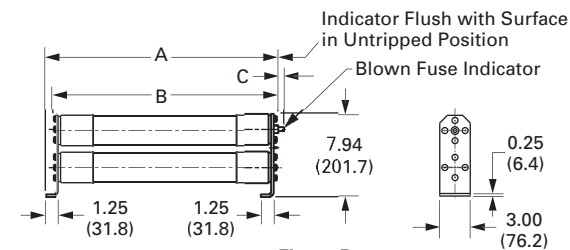
Ampere Rating	Number of Barrels	Figure Number	A	B	C	D	Interrupting Rating rms (kA Sym.)
<b>5.5 kV Maximum—Bolt-in Style—23.73-Inch (602.7 mm) Hole Centers—3.00-Inch (76.2 mm) Barrel Diameter</b>							
750E, 900E	3	C	25.11 (637.8)	22.37 (568.2)	23.73 (602.7)	①	63

**Type HCL Fuse Dimensional Details**

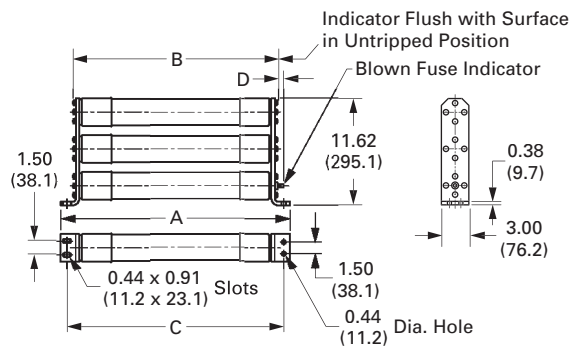
**Type HCL-14 Fuses**



**Figure A**

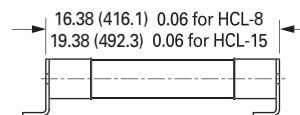


**Figure B**



**Figure C**

**Type HCL Fuses**



**Note**

① 0.5 (12.7) tripped force 2 lb (0.9 kg).



#### Type CLS

#### Type CLS Current Limiting Fuses

26

Maximum Design Voltage (kV)	Current Rating (Amperes)	"R" Designation	Barrel Number	Interrupting Rating rms (kA Sym.)	Diameter	Clip Center	Length	Approximate Shipping Weight Lbs (kg)	Performance Curves			Catalog Number
									Minimum Melting Time	Total Clearing Time	Peak Let-Through Current	
2.54	25	—	1	50	3.00 (76.2)	7.00 (177.8)	10.80 (274.3)	7 (3.18)	66664702	66664704	66700202	<b>2CLS-25</b>
	70	2R	1	50	3.00 (76.2)	7.00 (177.8)	10.80 (274.3)	7 (3.18)	66664702	66664704	66700202	<b>2CLS-2R</b>
	100	3R	1	50	3.00 (76.2)	7.00 (177.8)	10.80 (274.3)	7 (3.18)	66664702	66664704	66700202	<b>2CLS-3R</b>
	130	4R	1	50	3.00 (76.2)	7.00 (177.8)	10.80 (274.3)	7 (3.18)	66664702	66664704	66700202	<b>2CLS-4R</b>
	150	5R	1	50	3.00 (76.2)	7.00 (177.8)	10.80 (274.3)	7 (3.18)	66664702	66664704	66700202	<b>2CLS-5R</b>
	170	6R	1	50	3.00 (76.2)	7.00 (177.8)	10.80 (274.3)	7 (3.18)	66664702	66664704	66700202	<b>2CLS-6R</b>
	200	9R	1	50	3.00 (76.2)	7.00 (177.8)	10.80 (274.3)	7 (3.18)	66664702	66664704	66700202	<b>2CLS-9R</b>
	230	12R	1	50	3.00 (76.2)	7.00 (177.8)	10.80 (274.3)	7 (3.18)	66664702	66664704	66700202	<b>2CLS-12R</b>
	390	18R	2	50	3.00 (76.2)	7.00 (177.8)	10.80 (274.3)	16 (7.26)	66664702	66664704	66700202	<b>2CLS-18R</b>
	450	24R	2	50	3.00 (76.2)	7.00 (177.8)	10.80 (274.3)	16 (7.26)	66664702	66664704	66700202	<b>2CLS-24R</b>
	25	—	1	50	3.00 (76.2)	Not applicable	10.80 (274.3)	7 (3.18)	66664702	66664704	66700202	<b>2ACLS-25</b>
	70	2R	1	50	3.00 (76.2)	Not applicable	10.80 (274.3)	7 (3.18)	66664702	66664704	66700202	<b>2ACLS-2R</b>
	100	3R	1	50	3.00 (76.2)	Not applicable	10.80 (274.3)	7 (3.18)	66664702	66664704	66700202	<b>2ACLS-3R</b>
	130	4R	1	50	3.00 (76.2)	Not applicable	10.80 (274.3)	7 (3.18)	66664702	66664704	66700202	<b>2ACLS-4R</b>
	150	5R	1	50	3.00 (76.2)	Not applicable	10.80 (274.3)	7 (3.18)	66664702	66664704	66700202	<b>2ACLS-5R</b>
	170	6R	1	50	3.00 (76.2)	Not applicable	10.80 (274.3)	7 (3.18)	66664702	66664704	66700202	<b>2ACLS-6R</b>
	200	9R	1	50	3.00 (76.2)	Not applicable	10.80 (274.3)	7 (3.18)	66664702	66664704	66700202	<b>2ACLS-9R</b>
	230	12R	1	50	3.00 (76.2)	Not applicable	10.80 (274.3)	7 (3.18)	66664702	66664704	66700202	<b>2ACLS-12R</b>
	390	18R	2	50	3.00 (76.2)	Not applicable	10.80 (274.3)	16 (7.26)	66664702	66664704	66700202	<b>2ACLS-18R</b>
	450	24R	2	50	3.00 (76.2)	Not applicable	10.80 (274.3)	16 (7.26)	66664702	66664704	66700202	<b>2ACLS-24R</b>
	25	—	1	50	3.00 (76.2)	Not applicable	10.80 (274.3)	8 (3.63)	66664702	66664704	66700202	<b>2BCLS-25</b>
	70	2R	1	50	3.00 (76.2)	Not applicable	10.80 (274.3)	8 (3.63)	66664702	66664704	66700202	<b>2BCLS-2R</b>
	100	3R	1	50	3.00 (76.2)	Not applicable	10.80 (274.3)	8 (3.63)	66664702	66664704	66700202	<b>2BCLS-3R</b>
	130	4R	1	50	3.00 (76.2)	Not applicable	10.80 (274.3)	8 (3.63)	66664702	66664704	66700202	<b>2BCLS-4R</b>
	150	5R	1	50	3.00 (76.2)	Not applicable	10.80 (274.3)	8 (3.63)	66664702	66664704	66700202	<b>2BCLS-5R</b>
	170	6R	1	50	3.00 (76.2)	Not applicable	10.80 (274.3)	8 (3.63)	66664702	66664704	66700202	<b>2BCLS-6R</b>
	200	9R	1	50	3.00 (76.2)	Not applicable	10.80 (274.3)	8 (3.63)	66664702	66664704	66700202	<b>2BCLS-9R</b>
	230	12R	1	50	3.00 (76.2)	Not applicable	10.80 (274.3)	8 (3.63)	66664702	66664704	66700202	<b>2BCLS-12R</b>
	390	18R	2	50	3.00 (76.2)	Not applicable	10.80 (274.3)	17 (7.72)	66664702	66664704	66700202	<b>2BCLS-18R</b>
	450	24R	2	50	3.00 (76.2)	Not applicable	10.80 (274.3)	17 (7.72)	66664702	66664704	66700202	<b>2BCLS-24R</b>
	25	—	1	50	3.00 (76.2)	Not applicable	10.80 (274.3)	7 (3.18)	66664702	66664704	66700202	<b>2HCLS-25</b>
	70	2R	1	50	3.00 (76.2)	Not applicable	10.80 (274.3)	7 (3.18)	66664702	66664704	66700202	<b>2HCLS-2R</b>
	100	3R	1	50	3.00 (76.2)	Not applicable	10.80 (274.3)	7 (3.18)	66664702	66664704	66700202	<b>2HCLS-3R</b>
	130	4R	1	50	3.00 (76.2)	Not applicable	10.80 (274.3)	7 (3.18)	66664702	66664704	66700202	<b>2HCLS-4R</b>
	150	5R	1	50	3.00 (76.2)	Not applicable	10.80 (274.3)	7 (3.18)	66664702	66664704	66700202	<b>2HCLS-5R</b>
	170	6R	1	50	3.00 (76.2)	Not applicable	10.80 (274.3)	7 (3.18)	66664702	66664704	66700202	<b>2HCLS-6R</b>
	200	9R	1	50	3.00 (76.2)	Not applicable	10.80 (274.3)	7 (3.18)	66664702	66664704	66700202	<b>2HCLS-9R</b>
	230	12R	1	50	3.00 (76.2)	Not applicable	10.80 (274.3)	7 (3.18)	66664702	66664704	66700202	<b>2HCLS-12R</b>
	390	18R	2	50	3.00 (76.2)	Not applicable	10.80 (274.3)	16 (7.26)	66664702	66664704	66700202	<b>2HCLS-18R</b>
	450	24R	2	50	3.00 (76.2)	Not applicable	10.80 (274.3)	16 (7.26)	66664702	66664704	66700202	<b>2HCLS-24R</b>

**Note**

Approximate Dimensions in Inches (mm).

Type CLS Current Limiting Fuses, continued

Maximum Design Voltage (kV)	Current Rating (Amperes)	"R" Designation	Barrel Number	Interrupting Rating rms (kA Sym.)	Performance Curves							
					Diameter	Clip Center	Length	Approximate Shipping Weight Lbs (kg)	Minimum Melting Time	Total Clearing Time	Peak Let-Through Current	Catalog Number
5.08	30	—	1	50	3.00 (76.2)	12.00 (304.8)	15.90 (403.9)	8 (3.63)	66690602	66690702	66700203	<b>5CLS-30</b>
	70	2R	1	50	3.00 (76.2)	12.00 (304.8)	15.90 (403.9)	8 (3.63)	66690602	66690702	66700203	<b>5CLS-2R</b>
	100	3R	1	50	3.00 (76.2)	12.00 (304.8)	15.90 (403.9)	8 (3.63)	66690602	66690702	66700203	<b>5CLS-3R</b>
	130	4R	1	50	3.00 (76.2)	12.00 (304.8)	15.90 (403.9)	8 (3.63)	66690602	66690702	66700203	<b>5CLS-4R</b>
	150	5R	1	50	3.00 (76.2)	12.00 (304.8)	15.90 (403.9)	8 (3.63)	66690602	66690702	66700203	<b>5CLS-5R</b>
	170	6R	1	50	3.00 (76.2)	12.00 (304.8)	15.90 (403.9)	8 (3.63)	66690602	66690702	66700203	<b>5CLS-6R</b>
	200	9R	1	50	3.00 (76.2)	12.00 (304.8)	15.90 (403.9)	8 (3.63)	66690602	66690702	66700203	<b>5CLS-9R</b>
	230	12R	1	50	3.00 (76.2)	12.00 (304.8)	15.90 (403.9)	8 (3.63)	66690602	66690702	66700203	<b>5CLS-12R</b>
	390	18R	2	50	3.00 (76.2)	12.00 (304.8)	15.90 (403.9)	17 (7.72)	66690602	66690702	66700203	<b>5CLS-18R</b>
	450	24R	2	50	3.00 (76.2)	12.00 (304.8)	15.90 (403.9)	17 (7.72)	66690602	66690702	66700203	<b>5CLS-24R</b>
5.08	30	—	1	50	3.00 (76.2)	Not applicable	15.90 (403.9)	8 (3.63)	66690602	66690702	66700203	<b>5ACLS-30</b>
	70	2R	1	50	3.00 (76.2)	Not applicable	15.90 (403.9)	8 (3.63)	66690602	66690702	66700203	<b>5ACLS-2R</b>
	100	3R	1	50	3.00 (76.2)	Not applicable	15.90 (403.9)	8 (3.63)	66690602	66690702	66700203	<b>5ACLS-3R</b>
	130	4R	1	50	3.00 (76.2)	Not applicable	15.90 (403.9)	8 (3.63)	66690602	66690702	66700203	<b>5ACLS-4R</b>
	150	5R	1	50	3.00 (76.2)	Not applicable	15.90 (403.9)	8 (3.63)	66690602	66690702	66700203	<b>5ACLS-5R</b>
	170	6R	1	50	3.00 (76.2)	Not applicable	15.90 (403.9)	8 (3.63)	66690602	66690702	66700203	<b>5ACLS-6R</b>
	200	9R	1	50	3.00 (76.2)	Not applicable	15.90 (403.9)	8 (3.63)	66690602	66690702	66700203	<b>5ACLS-9R</b>
	230	12R	1	50	3.00 (76.2)	Not applicable	15.90 (403.9)	8 (3.63)	66690602	66690702	66700203	<b>5ACLS-12R</b>
	390	18R	2	50	3.00 (76.2)	Not applicable	15.90 (403.9)	17 (7.72)	66690602	66690702	66700203	<b>5ACLS-18R</b>
	450	24R	2	50	3.00 (76.2)	Not applicable	15.90 (403.9)	17 (7.72)	66690602	66690702	66700203	<b>5ACLS-24R</b>
4.3	480	26R	2	50	3.00 (76.2)	Not applicable	15.90 (403.9)	17 (7.72)	66690602	66690702	66700203	<b>4ACLS-26R</b>
5.08	30	—	1	50	3.00 (76.2)	Not applicable	15.90 (403.9)	8 (3.63)	66690602	66690702	66700203	<b>5BCLS-30</b>
	70	2R	1	50	3.00 (76.2)	Not applicable	15.90 (403.9)	8 (3.63)	66690602	66690702	66700203	<b>5BCLS-2R</b>
	100	3R	1	50	3.00 (76.2)	Not applicable	15.90 (403.9)	8 (3.63)	66690602	66690702	66700203	<b>5BCLS-3R</b>
	130	4R	1	50	3.00 (76.2)	Not applicable	15.90 (403.9)	8 (3.63)	66690602	66690702	66700203	<b>5BCLS-4R</b>
	150	5R	1	50	3.00 (76.2)	Not applicable	15.90 (403.9)	8 (3.63)	66690602	66690702	66700203	<b>5BCLS-5R</b>
	170	6R	1	50	3.00 (76.2)	Not applicable	15.90 (403.9)	8 (3.63)	66690602	66690702	66700203	<b>5BCLS-6R</b>
	200	9R	1	50	3.00 (76.2)	Not applicable	15.90 (403.9)	8 (3.63)	66690602	66690702	66700203	<b>5BCLS-9R</b>
	230	12R	1	50	3.00 (76.2)	Not applicable	15.90 (403.9)	8 (3.63)	66690602	66690702	66700203	<b>5BCLS-12R</b>
	390	18R	2	50	3.00 (76.2)	Not applicable	15.90 (403.9)	17 (7.72)	66690602	66690702	66700203	<b>5BCLS-18R</b>
	450	24R	2	50	3.00 (76.2)	Not applicable	15.90 (403.9)	17 (7.72)	66690602	66690702	66700203	<b>5BCLS-24R</b>
4.3	480	26R	2	50	3.00 (76.2)	Not applicable	15.90 (403.9)	17 (7.72)	66690602	66690702	66700203	<b>4BCLS-26R</b>
5.08	30	—	1	50	3.00 (76.2)	Not applicable	15.90 (403.9)	8 (3.63)	66690602	66690702	66700203	<b>5HCLS-30</b>
	70	2R	1	50	3.00 (76.2)	Not applicable	15.90 (403.9)	8 (3.63)	66690602	66690702	66700203	<b>5HCLS-2R</b>
	100	3R	1	50	3.00 (76.2)	Not applicable	15.90 (403.9)	8 (3.63)	66690602	66690702	66700203	<b>5HCLS-3R</b>
	130	4R	1	50	3.00 (76.2)	Not applicable	15.90 (403.9)	8 (3.63)	66690602	66690702	66700203	<b>5HCLS-4R</b>
	150	5R	1	50	3.00 (76.2)	Not applicable	15.90 (403.9)	8 (3.63)	66690602	66690702	66700203	<b>5HCLS-5R</b>
	170	6R	1	50	3.00 (76.2)	Not applicable	15.90 (403.9)	8 (3.63)	66690602	66690702	66700203	<b>5HCLS-6R</b>
	200	9R	1	50	3.00 (76.2)	Not applicable	15.90 (403.9)	8 (3.63)	66690602	66690702	66700203	<b>5HCLS-9R</b>
	230	12R	1	50	3.00 (76.2)	Not applicable	15.90 (403.9)	8 (3.63)	66690602	66690702	66700203	<b>5HCLS-12R</b>
	390	18R	2	50	3.00 (76.2)	Not applicable	15.90 (403.9)	17 (7.72)	66690602	66690702	66700203	<b>5HCLS-18R</b>
	450	24R	2	50	3.00 (76.2)	Not applicable	15.90 (403.9)	17 (7.72)	66690602	66690702	66700203	<b>5HCLS-24R</b>

**Note**  
Approximate Dimensions in Inches (mm).

#### Type CLS Current Limiting Fuses, continued

Maximum Design Voltage (kV)	Current Rating (Amperes)	"R" Designation	Barrel Number	Interrupting Rating rms (kA Sym.)	Diameter	Clip Center	Length	Approximate Shipping Weight Lbs (kg)	Performance Curves			Catalog Number
									Minimum Melting Time	Total Clearing Time	Peak Let-Through Current	
5.08	70	2R	2	50	3.00 (76.2)	Not applicable	15.90 (403.9)	20 (9.08)	66690602	66690702	66700203	<b>5CLS70-2R</b>
	100	3R	2	50	3.00 (76.2)	Not applicable	15.90 (403.9)	20 (9.08)	66690602	66690702	66700203	<b>5CLS70-3R</b>
	130	4R	2	50	3.00 (76.2)	Not applicable	15.90 (403.9)	20 (9.08)	66690602	66690702	66700203	<b>5CLS70-4R</b>
	150	5R	2	50	3.00 (76.2)	Not applicable	15.90 (403.9)	20 (9.08)	66690602	66690702	66700203	<b>5CLS70-5R</b>
	170	6R	2	50	3.00 (76.2)	Not applicable	15.90 (403.9)	20 (9.08)	66690602	66690702	66700203	<b>5CLS70-6R</b>
	200	9R	2	50	3.00 (76.2)	Not applicable	15.90 (403.9)	20 (9.08)	66690602	66690702	66700203	<b>5CLS70-9R</b>
	230	12R	2	50	4.00 (101.6)	Not applicable	15.90 (403.9)	40 (18.16)	66690602	66690702	66700203	<b>5CLS70-12R</b>
	390	18R	2	50	4.00 (101.6)	Not applicable	15.90 (403.9)	40 (18.16)	66690602	66690702	66700203	<b>5CLS70-18R</b>
	450	24R	2	50	4.00 (101.6)	Not applicable	15.90 (403.9)	40 (18.16)	66690602	66690702	66700203	<b>5CLS70-24R</b>
	600	32R	2	50	4.00 (101.6)	Not applicable	15.90 (403.9)	40 (18.16)	66690602	66690702	66700203	<b>5CLS70-32R</b>
	650	36R	2	50	4.00 (101.6)	Not applicable	15.90 (403.9)	40 (18.16)	66690602	66690702	66700203	<b>5CLS70-36R</b>
	700	44R	2	50	4.00 (101.6)	Not applicable	15.90 (403.9)	40 (18.16)	66690602	66690702	66700203	<b>5CLS70-44R</b>
5.5	70	2R	1	50	3.00 (76.2)	14.00 (355.6)	17.90 (454.7)	11 (4.99)	51285302	51285402	66700204	<b>5LCLS-2R</b>
	100	3R	1	50	3.00 (76.2)	14.00 (355.6)	17.90 (454.7)	11 (4.99)	51285302	51285402	66700204	<b>5LCLS-3R</b>
	130	4R	1	50	3.00 (76.2)	14.00 (355.6)	17.90 (454.7)	11 (4.99)	51285302	51285402	66700204	<b>5LCLS-4R</b>
	150	5R	1	50	3.00 (76.2)	14.00 (355.6)	17.90 (454.7)	11 (4.99)	51285302	51285402	66700204	<b>5LCLS-5R</b>
	170	6R	1	50	3.00 (76.2)	14.00 (355.6)	17.90 (454.7)	11 (4.99)	51285302	51285402	66700204	<b>5LCLS-6R</b>
	200	9R	1	50	3.00 (76.2)	14.00 (355.6)	17.90 (454.7)	11 (4.99)	51285302	51285402	66700204	<b>5LCLS-9R</b>
	230	12R	1	50	3.00 (76.2)	14.00 (355.6)	17.90 (454.7)	11 (4.99)	51285302	51285402	66700204	<b>5LCLS-12R</b>
	390	18R	2	50	3.00 (76.2)	14.00 (355.6)	17.90 (454.7)	22 (9.99)	51285302	51285402	66700204	<b>5LCLS-18R</b>
450	24R	2	50	3.00 (76.2)	14.00 (355.6)	17.90 (454.7)	22 (9.99)	51285302	51285402	66700204	<b>5LCLS-24R</b>	
8.3	70	2R	1	50	3.00 (76.2)	12.00 (304.8)	15.90 (403.9)	7 (3.18)	66700602	66700702	66700205	<b>8CLS-2R</b>
	100	3R	1	50	3.00 (76.2)	12.00 (304.8)	15.90 (403.9)	7 (3.18)	66700602	66700702	66700205	<b>8CLS-3R</b>
	130	4R	1	50	3.00 (76.2)	12.00 (304.8)	15.90 (403.9)	7 (3.18)	66700602	66700702	66700205	<b>8CLS-4R</b>
	150	5R	1	50	3.00 (76.2)	12.00 (304.8)	15.90 (403.9)	7 (3.18)	66700602	66700702	66700205	<b>8CLS-5R</b>
	170	6R	1	50	3.00 (76.2)	12.00 (304.8)	15.90 (403.9)	7 (3.18)	66700602	66700702	66700205	<b>8CLS-6R</b>
7.2	200	9R	1	50	3.00 (76.2)	12.00 (304.8)	15.90 (403.9)	7 (3.18)	66700602	66700702	66700205	<b>7CLS-9R</b>
	230	12R	1	50	3.00 (76.2)	12.00 (304.8)	15.90 (403.9)	7 (3.18)	66700602	66700702	66700205	<b>7CLS-12R</b>
	390	18R	2	50	3.00 (76.2)	12.00 (304.8)	15.90 (403.9)	16 (7.26)	66700602	66700702	66700205	<b>7CLS-18R</b>
	450	24R	2	50	3.00 (76.2)	12.00 (304.8)	15.90 (403.9)	16 (7.26)	66700602	66700702	66700205	<b>7CLS-24R</b>
8.3	70	2R	1	50	3.00 (76.2)	Not applicable	15.90 (403.9)	7 (3.18)	66700602	66700702	66740205	<b>7BCLS-2R</b>
	100	3R	1	50	3.00 (76.2)	Not applicable	15.90 (403.9)	7 (3.18)	66700602	66700702	66740205	<b>7BCLS-3R</b>
	130	4R	1	50	3.00 (76.2)	Not applicable	15.90 (403.9)	7 (3.18)	66700602	66700702	66740205	<b>7BCLS-4R</b>
	150	5R	1	50	3.00 (76.2)	Not applicable	15.90 (403.9)	7 (3.18)	66700602	66700702	66740205	<b>7BCLS-5R</b>
	170	6R	1	50	3.00 (76.2)	Not applicable	15.90 (403.9)	7 (3.18)	66700602	66700702	66740205	<b>7BCLS-6R</b>
7.2	200	9R	1	50	3.00 (76.2)	Not applicable	15.90 (403.9)	7 (3.18)	66700602	66700702	66740205	<b>7BCLS-9R</b>
	230	12R	1	50	3.00 (76.2)	Not applicable	15.90 (403.9)	7 (3.18)	66700602	66700702	66740205	<b>7BCLS-12R</b>
	390	18R	2	50	3.00 (76.2)	Not applicable	15.90 (403.9)	16 (7.26)	66700602	66700702	66740205	<b>7BCLS-18R</b>
	450	24R	2	50	3.00 (76.2)	Not applicable	15.90 (403.9)	16 (7.26)	66700602	66700702	66740205	<b>7BCLS-24R</b>
8.3	70	2R	1	50	3.00 (76.2)	Not applicable	15.90 (403.9)	8 (3.63)	66700602	66700702	66740205	<b>8ACLS-2R</b>
	100	3R	1	50	3.00 (76.2)	Not applicable	15.90 (403.9)	8 (3.63)	66700602	66700702	66740205	<b>8ACLS-3R</b>
	130	4R	1	50	3.00 (76.2)	Not applicable	15.90 (403.9)	8 (3.63)	66700602	66700702	66740205	<b>8ACLS-4R</b>
	150	5R	1	50	3.00 (76.2)	Not applicable	15.90 (403.9)	8 (3.63)	66700602	66700702	66740205	<b>8ACLS-5R</b>
	170	6R	1	50	3.00 (76.2)	Not applicable	15.90 (403.9)	8 (3.63)	66700602	66700702	66740205	<b>8ACLS-6R</b>

**Note**  
Approximate Dimensions in Inches (mm).

## Type CLS Current Limiting Fuses, continued

Maximum Design Voltage (kV)	Current Rating (Amperes)	"R" Designation	Barrel Number	Interrupting Rating rms (kA Sym.)	Diameter	Clip Center	Length	Approximate Shipping Weight Lbs (kg)	Performance Curves			Peak Let-Through Current	Catalog Number
									Minimum Melting Time	Total Clearing Time			
7.2	200	9R	1	50	3.00 (76.2)	Not applicable	15.90 (403.9)	8 (3.63)	66700602	66700702	66740205	<b>7ACLS-9R</b>	
	230	12R	1	50	3.00 (76.2)	Not applicable	15.90 (403.9)	8 (3.63)	66700602	66700702	66740205	<b>7ACLS-12R</b>	
	390	18R	2	50	3.00 (76.2)	Not applicable	15.90 (403.9)	17 (7.72)	66700602	66700702	66740205	<b>7ACLS-18R</b>	
	450	24R	2	50	3.00 (76.2)	Not applicable	15.90 (403.9)	17 (7.72)	66700602	66700702	66740205	<b>7ACLS-24R</b>	
	450	24R	2	50	3.00 (76.2)	Not applicable	15.90 (403.9)	20 (9.08)	66700602	66700702	66740205	<b>7CLS70-24R</b>	
	650	36R	3	50	3.00 (76.2)	Not applicable	15.90 (403.9)	30 (13.62)	66700602	66700702	66740205	<b>7CLS70-36R</b>	
	700	44R	2	50	4.00 (101.6)	Not applicable	15.90 (403.9)	40 (18.16)	66700602	66700702	66740205	<b>7CLS70-44R</b>	
8.3	15	Not applicable	1	50	3.00 (76.2)	14.00 (355.6)	17.90 (454.7)	11 (4.99)	66664202	66664302	66679802	<b>8CLS-15</b>	
	30	Not applicable	1	50	3.00 (76.2)	14.00 (355.6)	17.90 (454.7)	11 (4.99)	66664202	66664302	66679802	<b>8CLS-30</b>	
	60	Not applicable	1	50	3.00 (76.2)	14.00 (355.6)	17.90 (454.7)	11 (4.99)	66664202	66664302	66679802	<b>8CLS-60</b>	
	70	Not applicable	1	50	3.00 (76.2)	14.00 (355.6)	17.90 (454.7)	11 (4.99)	66664202	66664302	66679802	<b>8CLS-70</b>	
	90	Not applicable	1	50	3.00 (76.2)	14.00 (355.6)	17.90 (454.7)	11 (4.99)	66664202	66664302	66679802	<b>8CLS-90</b>	
	110	Not applicable	1	50	3.00 (76.2)	14.00 (355.6)	17.90 (454.7)	11 (4.99)	66664202	66664302	66679802	<b>8CLS-110</b>	
	125	Not applicable	1	50	3.00 (76.2)	14.00 (355.6)	17.90 (454.7)	11 (4.99)	66664202	66664302	66679802	<b>8CLS-125</b>	
	150	Not applicable	2	50	3.00 (76.2)	14.00 (355.6)	17.90 (454.7)	22 (9.99)	66664202	66664302	66679802	<b>8CLS-150</b>	
	200	Not applicable	2	50	3.00 (76.2)	14.00 (355.6)	17.90 (454.7)	22 (9.99)	66664202	66664302	66679802	<b>8CLS-200</b>	
225	Not applicable	2	50	3.00 (76.2)	14.00 (355.6)	17.90 (454.7)	22 (9.99)	66664202	66664302	66679802	<b>8CLS-225</b>		

**Note**

Approximate Dimensions in Inches (mm).

# 26.5

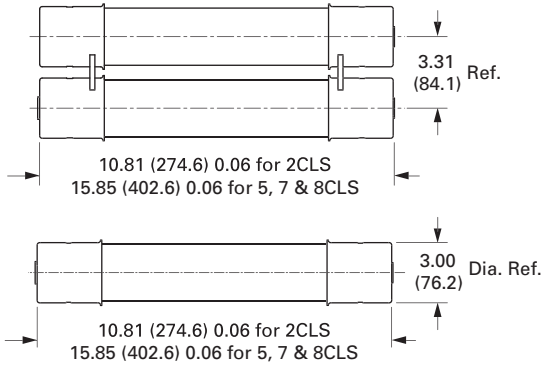
## Power Breakers, Contactors and Fuses

### Current Limiting Fuses

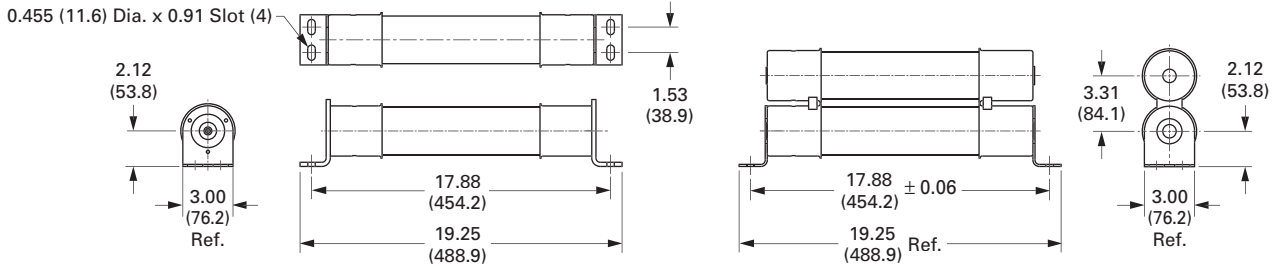
#### Fuse Dimensional Details

Approximate Dimensions in Inches (mm)

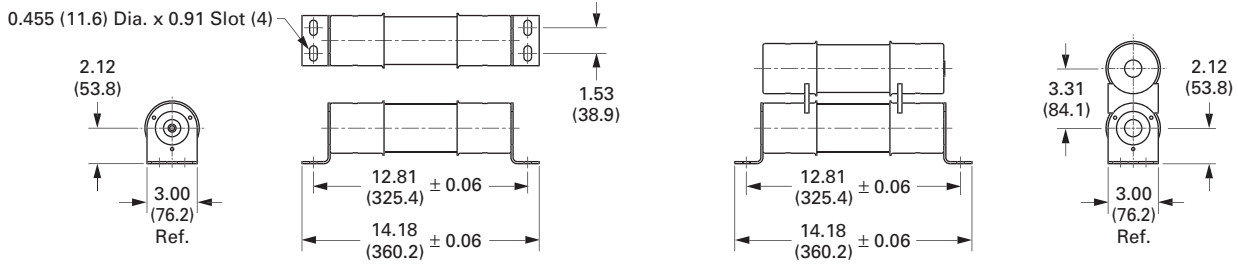
#### Type CLS Fuse



#### Type BCLS Fuse



Type 5BCLS and 7BCLS Fuses



Type 2BCLS Fuse

Type CLS Mountings and Hardware

Maximum Design Voltage (kV)	Ampere Rating	Fuse Mounting Type	Voltage BIL (kV)	Mounting (Including Live Parts, End Fittings) ①		Live Parts (Including End Fittings)	End Fittings (Disconnect Only) ①
				Porcelain Insulator	Glass-Polyester Insulator	Catalog Number	Catalog Number
				Porcelain Insulator Catalog Number	Glass-Polyester Insulator Catalog Number	Catalog Number	Catalog Number
2.54	25–230	Non-disconnect	60	2CLE-PNM-D	2CLE-GNM-D	CLE-NL-D	—
		Disconnect	60	2CLE-PDM-D	2CLE-GDM-E	CLE-DL-D	CLE-DF-D
	390–450	Non-disconnect	60	2CLE-PNM-E	2CLE-GNM-E	CLE-NL-E	—
		Disconnect	60	2CLE-PDM-E	2CLE-GDM-E	CLE-DL-E	CLE-DF-E
5.5 (CLS)	30–230	Non-disconnect	60	5HLE-PNM-D	5HLE-GNM-D	CLE-NL-D	—
		Disconnect	60	5HLE-PDM-D	5HLE-GDM-E	CLE-DL-D	CLE-DF-D
	390–480	Non-disconnect	60	5HLE-PNM-E	5HLE-GNM-E	CLE-NL-E	—
		Disconnect	60	5HLE-PDM-E	5HLE-GDM-E	CLE-DL-E	CLE-DF-E
5.5 (LCLS)	70–230	Non-disconnect	60	5CLE-PNM-D	5CLE-GNM-D	CLE-NL-D	—
		Disconnect	60	5CLE-PDM-D	5CLE-GDM-D	CLE-DL-D	CLE-DF-D
			75	8CLE-PDM-D	8CLE-GDM-D	CLE-DL-D	CLE-DF-D
	390–450	Non-disconnect	60	5CLE-PNM-E	5CLE-GNM-E	CLE-NL-E	—
		Disconnect	60	5CLE-PDM-E	5CLE-GDM-E	CLE-DL-E	CLE-DF-E
			75	8CLE-PDM-E	8CLE-PDM-E	CLE-DL-E	CLE-DF-E
8.3	70–100	Non-disconnect	75	8HLE-PNM-D	8HLE-GNM-D	CLE-NL-D	—
	130–230	Disconnect	75	8HLE-PDM-D	8HLE-GDM-D	CLE-DL-D	CLE-DF-D
7.2	390–450	Non-disconnect	75	8HLE-PDM-E	8HLE-GNM-E	CLE-NL-E	—
		Disconnect	75	8HLE-PDM-E	8HLE-GDM-E	CLE-DL-E	CLE-DF-E
8.3	15–30	Non-disconnect	75	8CLE-PNM-D	8CLE-GNM-D	CLE-NL-D	—
	60–125	Disconnect	75	8CLE-PDM-D	8CLE-GDM-D	CLE-DL-D	CLS-DF-D
	150–225	Non-disconnect	75	8CLE-PNM-E	8CLE-GNM-E	CLE-NL-E	—
		Disconnect	75	8CLE-PDM-E	8CLE-GDM-E	CLE-DL-E	CLE-DF-E

Note

① Disconnect only.

## Type CLPT

Indicating

## Type CLPT Current Limiting Fuses 2.475 kV Maximum (2.4 kV Nominal)



Current Rating (Amperes)	Interrupting Rating rms (kA Sym.)	Diameter	Clip Center	Length	Approximate Shipping Weight Lbs (kg)	Performance Curves			Catalog Number
						Minimum Melting Time	Total Clearing Time	Peak Let-Through Current	
0.25E	63	0.81 (20.6)	—	4.50 (114.3)	0.25 (0.11)	56357202	59883702	63933702	<b>2NCLPT-.25E</b>
0.5E	63	0.81 (20.6)	—	4.50 (114.3)	0.25 (0.11)	56357202	59883702	63933702	<b>2NCLPT-.5E</b>
1E	40	0.81 (20.6)	—	4.50 (114.3)	0.25 (0.11)	56357202	59883702	63933702	<b>2NCLPT-1E</b>
2E	40	0.81 (20.6)	—	4.50 (114.3)	0.25 (0.11)	56357202	59883702	63933702	<b>2NCLPT-2E</b>
5E	25	0.81 (20.6)	—	4.50 (114.3)	0.25 (0.11)	56357202	59883702	63933702	<b>2NCLPT-5E</b>

**Note**

Approximate Dimensions in Inches (mm).

Type CLPT Current Limiting Fuses 5.5 kV Maximum (4.8 kV Nominal)

Current Rating (Amperes)	Interrupting Rating rms (kA Sym.)	Diameter	Clip Center	Length	Approximate Shipping Weight Lbs (kg)	Performance Curves		Peak Let-Through Current	Catalog Number
						Minimum Melting Time	Total Clearing Time		
<b>Non-Indicating</b>									
<b>Non-Indicating</b>									
0.5E	63	0.81 (20.6)	—	5.63 (143.0)	0.25 (0.11)	66702402	66702502	66704101	5NCLPT-.5E
1E	63	0.81 (20.6)	—	5.63 (143.0)	0.25 (0.11)	66702402	66702502	66704101	5NCLPT-1E
2E	63	0.81 (20.6)	—	5.63 (143.0)	0.25 (0.11)	66702402	66702502	66704101	5NCLPT-2E
3E	63	0.81 (20.6)	—	5.63 (143.0)	0.25 (0.11)	66702402	66702502	66704101	5NCLPT-3E
4E	63	0.81 (20.6)	—	5.63 (143.0)	0.25 (0.11)	66702402	66702502	66704101	5NCLPT-4E
5E	63	0.81 (20.6)	—	5.63 (143.0)	0.25 (0.11)	66702402	66702502	66704101	5NCLPT-5E
0.5E	50	1.00 (25.4)	—	5.63 (143.0)	0.25 (0.11)	66702402	66702502	66704101	317B487H02
1E	50	1.00 (25.4)	—	5.63 (143.0)	0.25 (0.11)	66702402	66702502	66704101	317B487H06
2E	50	1.00 (25.4)	—	5.63 (143.0)	0.25 (0.11)	66702402	66702502	66704101	317B487H03
3E	50	1.00 (25.4)	—	5.63 (143.0)	0.25 (0.11)	66702402	66702502	66704101	317B487H04
5E	50	1.00 (25.4)	—	5.63 (143.0)	0.25 (0.11)	66702402	66702502	66704101	317B487H05
0.5E	63	1.60 (40.6)	8.10 (205.7)	9.50 (241.3)	1.2 (0.54)	70548302	70548402	63934002	5NCLPT-.5E-A
1E	63	1.60 (40.6)	8.10 (205.7)	9.50 (241.3)	1.2 (0.54)	70548302	70548402	63934002	5NCLPT-1E-A
2E	63	1.60 (40.6)	8.10 (205.7)	9.50 (241.3)	1.2 (0.54)	70548302	70548402	63934002	5NCLPT-2E-A
3E	63	1.60 (40.6)	8.10 (205.7)	9.50 (241.3)	1.2 (0.54)	70548302	70548402	63934002	5NCLPT-3E-A
5E	63	1.60 (40.6)	8.10 (205.7)	9.50 (241.3)	1.2 (0.54)	70548302	70548402	63934002	5NCLPT-5E-A
10E	63	1.60 (40.6)	8.10 (205.7)	9.50 (241.3)	1.2 (0.54)	70548302	70548402	63934002	5NCLPT-10E-A
<b>Indicating</b>									
<b>Indicating</b>									
0.5E	80	1.60 (40.6)	8.10 (205.7)	9.50 (241.3)	1.2 (0.54)	56353206	56353306	63934001	5CLPT-.5E
1E	80	1.60 (40.6)	8.10 (205.7)	9.50 (241.3)	1.2 (0.54)	56353206	56353306	63934001	5CLPT-1E
1.5E	80	1.60 (40.6)	8.10 (205.7)	9.50 (241.3)	1.2 (0.54)	56353206	56353306	63934001	5CLPT-1.5E
3E	80	1.60 (40.6)	8.10 (205.7)	9.50 (241.3)	1.2 (0.54)	56353206	56353306	63934001	5CLPT-3E
5E	80	1.60 (40.6)	8.10 (205.7)	9.50 (241.3)	1.2 (0.54)	56353206	56353306	63934001	5CLPT-5E
10E	80	1.60 (40.6)	8.10 (205.7)	9.50 (241.3)	1.2 (0.54)	56353206	56353306	63934001	5CLPT-10E

Non-Indicating



Indicating



Type CLPT Mountings and Hardware 5.5 kV Maximum (4.8 kV Nominal) ③

Ampere Rating	Fuse Mounting Type ①	Voltage BIL (kV)	Mounting (Including Live Parts, End Fittings) ②		Live Parts (Including End Fittings) ②	End Fittings (Disconnect Only)
			Porcelain Insulator Catalog Number	Glass-Polyester Insulator Catalog Number		
0.5-2	Non-disconnect	60	5CLPT-PNM-A	5CLPT-GNM-A	CLPT-NL	—
	Disconnect	60	5CLPT-PDM-A	5CLPT-GDM-A	CLPT-DL	CLPT-DF
3-10	Non-disconnect	60	5CLPT-PNM-B	5CLPT-GNM-B	CLPT-NL	—
	Disconnect	60	5CLPT-PDM-B	5CLPT-GDM-B	CLPT-DL	CLPT-DF

Notes

① See Page V4-T26-127 for diagram of typical mounting.

② End fittings supplied only when required.

③ Refers only to 5CLPT and 5NCLPT-A fuses only.

Approximate Dimensions in Inches (mm).



#### Type CLPT Current Limiting Fuses 8.3 kV Maximum (7.2 kV Nominal)

Current Rating (Amperes)	Interrupting Rating rms (kA Sym.)	Diameter	Clip Center	Length	Approximate Shipping Weight Lbs (kg)	Performance Curves		Peak Let-Through Current	Catalog Number
						Minimum Melting Time	Total Clearing Time		
<b>Non-Indicating</b>									
<b>Non-Indicating</b>									
2E	25	0.81 (20.6)	—	8.00 (203.2)	0.25 (0.11)	56357206	59883706	63933704	<b>8NCLPT-2E</b>
4E	25	0.81 (20.6)	—	8.00 (203.2)	0.25 (0.11)	56357206	59883706	63933704	<b>8NCLPT-4E</b>
10E	50	1.10 (27.9)	—	5.00 (127.0)	0.5 (0.23)	56357206	59883706	63933704	<b>8NCLPT-0E</b>
1E	50	1.10 (27.9)	—	5.00 (127.0)	0.5 (0.23)	56357206	59883706	63933704	<b>8NCLPT-1E</b>
5E	50	1.10 (27.9)	—	5.00 (127.0)	0.5 (0.23)	56357206	59883706	63933704	<b>8NCLPT-5E</b>
0.5E	50	1.60 (40.6)	8.10 (205.7)	9.50 (241.3)	1.5 (0.70)	70548303	70548403	63934002	<b>8NCLPT-.5E-A</b>
1E	50	1.60 (40.6)	8.10 (205.7)	9.50 (241.3)	1.5 (0.70)	70548303	70548403	63934002	<b>8NCLPT-1E-A</b>
2E	50	1.60 (40.6)	8.10 (205.7)	9.50 (241.3)	1.5 (0.70)	70548303	70548403	63934002	<b>8NCLPT-2E-A</b>
3E	50	1.60 (40.6)	8.10 (205.7)	9.50 (241.3)	1.5 (0.70)	70548303	70548403	63934002	<b>8NCLPT-3E-B</b>
5E	50	1.60 (40.6)	11.50 (292.1)	12.90 (327.7)	1.6 (0.73)	70548303	70548403	63934002	<b>8NCLPT-5E-B</b>
10E	50	1.60 (40.6)	11.50 (292.1)	12.90 (327.7)	1.6 (0.73)	70548303	70548403	63934002	<b>8NCLPT-10E-B</b>
<b>Indicating</b>									
<b>Indicating</b>									
.5E	80	1.60 (40.6)	8.10 (205.7)	9.50 (241.3)	1.5 (0.70)	56353206	56353306	63934001	<b>8CLPT-.5E</b>
3E	80	1.60 (40.6)	8.10 (205.7)	9.50 (241.3)	1.6 (0.73)	56353206	56353306	63934001	<b>8CLPT-3E</b>
5E	50	1.60 (40.6)	8.10 (205.7)	9.50 (241.3)	1.6 (0.73)	56353206	56353306	63934001	<b>8CLPT-5E</b>
10E	50	1.60 (40.6)	8.10 (205.7)	9.50 (241.3)	1.6 (0.73)	56353206	56353306	63934001	<b>8CLPT-10E</b>

#### Type CLPT Mountings and Hardware 8.3 kV Maximum (7.2 kV Nominal) <sup>③</sup>

Ampere Rating	Fuse Mounting Type <sup>①</sup>	Voltage BIL (kV)	Mounting (Including Live Parts, End Fittings) <sup>②</sup>		Live Parts (Including End Fittings) <sup>②</sup>	End Fittings (Disconnect Only)
			Porcelain Insulator Catalog Number	Glass-Polyester Insulator Catalog Number		
0.5–2	Non-disconnect	75	<b>8CLPT-PNM-A</b>	<b>8CLPT-GNM-A</b>	<b>CLPT-NL</b>	—
	Disconnect	75	<b>8CLPT-PDM-A</b>	<b>8CLPT-GDM-A</b>	<b>CLPT-DL</b>	<b>CLPT-DF</b>
3–10	Non-disconnect	75	<b>8CLPT-PNM-B</b>	<b>8CLPT-GNM-B</b>	<b>CLPT-NL</b>	—
	Disconnect	75	<b>8CLPT-PDM-B</b>	<b>8CLPT-GDM-B</b>	<b>CLPT-DL</b>	<b>CLPT-DF</b>

#### Notes

<sup>①</sup> See **Page V4-T26-127** for diagram of typical mounting.

<sup>②</sup> End fittings supplied only when required.

<sup>③</sup> Refers only to 8CLPT and 8NCLPT-A or -B fuses only.

Approximate Dimensions in Inches (mm).





Non-Indicating



Indicating

**Type CLPT Current Limiting Fuses 15.5 kV Maximum (7.2 kV Nominal)**

	Current Rating (Amperes)	Interrupting Rating rms (kA Sym.)	Diameter	Clip Center	Length	Approximate Shipping Weight Lbs (kg)	Performance Curves		Peak Let-Through Current	Catalog Number
							Minimum Melting Time	Total Clearing Time		
<b>Non-Indicating</b>	<b>Non-Indicating</b>									
	0.5E	63	1.60 (40.6)	11.50 (292.1)	12.90 (327.7)	1.6 (0.73)	70548303	70548403	63934002	<b>15NCLPT-5E</b>
	1E	63	1.60 (40.6)	11.50 (292.1)	12.90 (327.7)	1.6 (0.73)	70548303	70548403	63934002	<b>15NCLPT-1E</b>
	2E	63	1.60 (40.6)	11.50 (292.1)	12.90 (327.7)	1.6 (0.73)	70548303	70548403	63934002	<b>15NCLPT-1.5E</b>
	3E	63	1.60 (40.6)	16.10 (408.9)	17.60 (447.0)	2 (0.91)	70548303	70548403	63934002	<b>15NCLPT-3E</b>
	5E	63	1.60 (40.6)	16.10 (408.9)	17.60 (447.0)	2 (0.91)	70548303	70548403	63934002	<b>15NCLPT-5E</b>
	10E	63	1.60 (40.6)	16.10 (408.9)	17.60 (447.0)	2 (0.91)	70548303	70548403	63934002	<b>15NCLPT-10E</b>
<b>Indicating</b>	<b>Indicating</b>									
	0.5E	80	1.60 (40.6)	11.50 (292.1)	12.90 (327.7)	1.6 (0.73)	56353206	56353306	63934001	<b>15CLPT-5E</b>
	1E	80	1.60 (40.6)	11.50 (292.1)	12.90 (327.7)	1.6 (0.73)	56353206	56353306	63934001	<b>15CLPT-1E</b>
	2E	80	1.60 (40.6)	11.50 (292.1)	12.90 (327.7)	1.6 (0.73)	56353206	56353306	63934001	<b>15CLPT-1.5E</b>
	3E	80	1.60 (40.6)	16.10 (408.9)	17.60 (447.0)	2 (0.91)	56353206	56353306	63934001	<b>15CLPT-3E</b>
	5E	80	1.60 (40.6)	16.10 (408.9)	17.60 (447.0)	2 (0.91)	56353206	56353306	63934001	<b>15CLPT-5E</b>
	10E	50	1.60 (40.6)	16.10 (408.9)	17.60 (447.0)	2 (0.91)	56353206	56353306	63934001	<b>15CLPT-10E</b>

**Type CLPT Mountings and Hardware 15.5 kV Maximum (14.4 kV Nominal)**

Ampere Rating	Fuse Mounting Type ①	Voltage BIL (kV)	Mounting (Including Live Parts, End Fittings) ②		Live Parts (Including End Fittings) ②	End Fittings (Disconnect Only)
			Porcelain Insulator Catalog Number	Glass-Polyester Insulator Catalog Number		
0.5-2	Non-disconnect	95	<b>15CLPT-PNM-A</b>	<b>15CLPT-GNM-A</b>	<b>CLPT-NL</b>	—
	Disconnect	95	<b>15CLPT-PDM-A</b>	<b>15CLPT-GDM-A</b>	<b>CLPT-DL</b>	<b>CLPT-DF</b>
3-10	Non-disconnect	95	<b>15CLPT-PNM-B</b>	<b>15CLPT-GNM-B</b>	<b>CLPT-NL</b>	<b>CLPT-DF</b>
	Disconnect	95	<b>15CLPT-PDM-B</b>	<b>15CLPT-GDM-B</b>	<b>CLPT-DL</b>	—

**Notes**

① See Page V4-T26-127 for diagram of typical mounting.

② End fittings supplied only when required.

Approximate Dimensions in Inches (mm).

## Type CLPT Current Limiting Fuses 25.5 kV Maximum (23.0 kV Nominal)

Current Rating (Amperes)	Interrupting Rating rms (kA Sym.)	Diameter	Clip Center	Length	Approximate Shipping Weight Lbs (kg)	Performance Curves			Catalog Number
						Minimum Melting Time	Total Clearing Time	Peak Let-Through Current	
0.5E	44	1.60 (40.6)	16.10 (408.9)	17.60 (447.0)	2 (0.91)	56353208	56353308	63933901	25CLPT-5E
1E	44	1.60 (40.6)	16.10 (408.9)	17.60 (447.0)	2 (0.91)	56353208	56353308	63933901	25CLPT-1E

## Type CLPT Mountings and Hardware 25.5 kV Maximum (23.0 kV Nominal)

Ampere Rating	Fuse Mounting Type <sup>①</sup>	Voltage BIL (kV)	Mounting (Including Live Parts, End Fittings) <sup>②</sup>		Live Parts (Including End Fittings) <sup>②</sup>	End Fittings (Disconnect Only)
			Porcelain Insulator Catalog Number	Glass-Polyester Insulator Catalog Number		
0.5E-1E	Non-disconnect	150	25CLPT-PNM-A	—	25CLPT-NL	—
	Disconnect	150	25CLPT-PDM-A	—	25CLPT-DL	CLPT-DF

## Type CLPT Current Limiting Fuses 38.0 kV Maximum (34.5 kV Nominal)

Current Rating (Amperes)	Interrupting Rating rms (kA Sym.)	Diameter	Clip Center	Length	Approximate Shipping Weight Lbs (kg)	Performance Curves			Catalog Number
						Minimum Melting Time	Total Clearing Time	Peak Let-Through Current	
0.5E	44	1.60 (40.6)	17.10 (434.3)	18.60 (472.4)	2 (0.91)	56353208	56353308	63933901	38CLPT-5E

## Type CLPT Mountings and Hardware 38.0 kV Maximum (34.5 kV Nominal)

Ampere Rating	Fuse Mounting Type <sup>①</sup>	Voltage BIL (kV)	Mounting (Including Live Parts, End Fittings) <sup>②</sup>		Live Parts (Including End Fittings) <sup>②</sup>	End Fittings (Disconnect Only)
			Porcelain Insulator Catalog Number	Glass-Polyester Insulator Catalog Number		
0.5E	Disconnect	—	Not applicable	Not applicable	25CLPT-NL	CLPT-DF
	Non-disconnect	—	Not applicable	Not applicable	25CLPT-DL	—

**Notes**

<sup>①</sup> See **Page V4-T26-127** for diagram of typical mounting.

<sup>②</sup> End fittings supplied only when required.

Approximate Dimensions in Inches (mm).

Type CX

Type CX



Type CX Current Limiting Fuses 4.3 kV Maximum (2.4 kV Nominal)

Current Rating (Amperes)	Barrel Number	Interrupting Rating rms (kA Sym.)	Fuse Mounting Code	Diameter	Length	Approximate Shipping Weight Lbs (kg)	Performance Curves				Catalog Number
							Minimum Melting Time	Total Clearing Time	Peak Let-Through Current	$i^2t$	
<b>Non-Indicating</b>											
18C	1	50	G	1.13 (28.7)	10.00 (254.0)	1 (0.45)	TC70544101	TC70544501	TC70544901	TC70545101	<b>4CX-18C</b>
25C	1	50	G	1.13 (28.7)	10.00 (254.0)	1 (0.45)	TC70544101	TC70544501	TC70544901	TC70545101	<b>4CX-25C</b>
35C	1	50	G	2.00 (50.8)	10.00 (254.0)	1 (0.45)	TC70544101	TC70544501	TC70544901	TC70545101	<b>4CX-35C</b>
45C	1	50	G	2.00 (50.8)	10.00 (254.0)	2 (0.91)	TC70544101	TC70544501	TC70544901	TC70545101	<b>4CX-45C</b>
50C	1	50	G	2.00 (50.8)	10.00 (254.0)	2 (0.91)	TC70544101	TC70544501	TC70544901	TC70545101	<b>4CX-50C</b>
60C	1	50	G	2.00 (50.8)	10.00 (254.0)	2 (0.91)	TC70544102	TC70544502	TC70544901	TC70545101	<b>4CX-60C</b>
65C	1	50	G	2.00 (50.8)	10.00 (254.0)	2 (0.91)	TC70544102	TC70544501	TC70544901	TC70545101	<b>4CX-65C</b>
75C	1	50	G	2.00 (50.8)	10.00 (254.0)	2 (0.91)	TC70544102	TC70544501	TC70544901	TC70545101	<b>4CX-75C</b>
80C	1	50	G	2.00 (50.8)	10.00 (254.0)	2 (0.91)	TC70544102	TC70544502	TC70544901	TC70545101	<b>4CX-80C</b>
100C	1	50	G	2.00 (50.8)	10.00 (254.0)	2 (0.91)	TC70544102	TC70544501	TC70544901	TC70545101	<b>4CX-100C</b>
<b>Indicating</b>											
18C	1	50	G	1.13 (28.7)	10.00 (254.0)	1 (0.45)	TC70544101	TC70544501	TC70544901	TC70545101	<b>4CXI-18C</b>
25C	1	50	G	1.13 (28.7)	10.00 (254.0)	1 (0.45)	TC70544101	TC70544501	TC70544901	TC70545101	<b>4CXI-25C</b>
35C	1	50	G	2.00 (50.8)	10.00 (254.0)	1 (0.45)	TC70544101	TC70544501	TC70544901	TC70545101	<b>4CXI-35C</b>
45C	1	50	G	2.00 (50.8)	10.00 (254.0)	2 (0.91)	TC70544101	TC70544501	TC70544901	TC70545101	<b>4CXI-45C</b>
50C	1	50	G	2.00 (50.8)	10.00 (254.0)	2 (0.91)	TC70544101	TC70544501	TC70544901	TC70545101	<b>4CXI-50C</b>
60C	1	50	G	2.00 (50.8)	10.00 (254.0)	2 (0.91)	TC70544102	TC70544502	TC70544901	TC70545101	<b>4CXI-60C</b>
65C	1	50	G	2.00 (50.8)	10.00 (254.0)	2 (0.91)	TC70544102	TC70544501	TC70544901	TC70545101	<b>4CXI-65C</b>
75C	1	50	G	2.00 (50.8)	10.00 (254.0)	2 (0.91)	TC70544102	TC70544501	TC70544901	TC70545101	<b>4CXI-75C</b>
80C	1	50	G	2.00 (50.8)	10.00 (254.0)	2 (0.91)	TC70544102	TC70544502	TC70544901	TC70545101	<b>4CXI-80C</b>
100C	1	50	G	2.00 (50.8)	10.00 (254.0)	2 (0.91)	TC70544102	TC70544501	TC70544901	TC70545101	<b>4CXI-100C</b>

Type CX Mountings and Hardware 4.3 kV Maximum (2.4 kV Nominal)

Ampere Rating	Fuse Mounting Type <sup>①</sup>	Size	Voltage BIL (kV)	Mounting (Including Live Parts, End Fittings) <sup>②</sup>		Live Parts (Including End Fittings) <sup>②</sup>	End Fittings (Disconnect Only)
				Porcelain Insulator Catalog Number	Glass-Polyester Insulator Catalog Number		
18C–100C	Non-disconnect	A	60	—	<b>5CX-GNM-G</b>	<b>CX-NL</b>	—
	Disconnect	A	60	—	<b>5CX-GDM-G</b>	<b>CX-DL</b>	<b>CX-DF</b>

Notes

<sup>①</sup> See Page V4-T26-127 for diagram of typical mounting.

<sup>②</sup> End fittings supplied only when required.

Approximate Dimensions in Inches (mm).

Type CX



#### Type CX Current Limiting Fuses 5.5 kV Maximum (4.8 kV Nominal)

Current Rating (Amperes)	Barrel Number	Interrupting Rating rms (kA Sym.)	Fuse Mounting Code	Diameter	Length	Approximate Shipping Weight Lbs (kg)	Performance Curves				Catalog Number
							Minimum Melting Time	Total Clearing Time	Peak Let-Through Current	I <sup>2</sup> t	
<b>Non-Indicating</b>											
10C	1	50	G	1.13 (28.7)	10.00 (254.0)	1 (0.45)	TC70544201	TC70544601	TC70544902	TC70545201	<b>5CX-10C</b>
12C	1	50	G	1.13 (28.7)	10.00 (254.0)	1 (0.45)	TC70544201	TC70544601	TC70544902	TC70545201	<b>5CX-12C</b>
18C	1	50	G	1.13 (28.7)	10.00 (254.0)	1 (0.45)	TC70544201	TC70544601	TC70544902	TC70545201	<b>5CX-18C</b>
20C	1	50	G	1.13 (28.7)	10.00 (254.0)	1 (0.45)	TC70544201	TC70544601	TC70544902	TC70545201	<b>5CX-20C</b>
21C	1	50	G	2.00 (50.8)	10.00 (254.0)	2 (0.91)	TC70544202	TC70544602	TC70544902	TC70545201	<b>5CX-21C</b>
25C	1	50	G	2.00 (50.8)	10.00 (254.0)	2 (0.91)	TC70544201	TC70544601	TC70544902	TC70545201	<b>5CX-25C</b>
30C	1	50	G	1.13 (28.7)	10.00 (254.0)	1 (0.45)	TC70544201	TC70544601	TC70544902	TC70545201	<b>5CX-30C</b>
35C	1	50	G	2.00 (50.8)	10.00 (254.0)	2 (0.91)	TC70544202	TC70544602	TC70544902	TC70545201	<b>5CX-35C</b>
40C	1	50	G	2.00 (50.8)	10.00 (254.0)	2 (0.91)	TC70544201	TC70544601	TC70544902	TC70545201	<b>5CX-40C</b>
50C	1	50	G	2.00 (50.8)	10.00 (254.0)	2 (0.91)	TC70544201	TC70544601	TC70544902	TC70545201	<b>5CX-50C</b>
60C	1	50	G	2.00 (50.8)	10.00 (254.0)	2 (0.91)	TC70544202	TC70544602	TC70544902	TC70545201	<b>5CX-60C</b>
65C	1	50	G	2.00 (50.8)	10.00 (254.0)	2 (0.91)	TC70544201	TC70544601	TC70544902	TC70545201	<b>5CX-65C</b>
75C	1	50	G	2.00 (50.8)	10.00 (254.0)	2 (0.91)	TC70544201	TC70544601	TC70544902	TC70545201	<b>5CX-75C</b>
<b>Indicating</b>											
10C	1	50	G	1.13 (28.7)	10.00 (254.0)	1 (0.45)	TC70544201	TC70544601	TC70544902	TC70545201	<b>5CXI-10C</b>
12C	1	50	G	1.13 (28.7)	10.00 (254.0)	1 (0.45)	TC70544201	TC70544601	TC70544902	TC70545201	<b>5CXI-12C</b>
18C	1	50	G	1.13 (28.7)	10.00 (254.0)	1 (0.45)	TC70544201	TC70544601	TC70544902	TC70545201	<b>5CXI-18C</b>
20C	1	50	G	1.13 (28.7)	10.00 (254.0)	1 (0.45)	TC70544201	TC70544601	TC70544902	TC70545201	<b>5CXI-20C</b>
21C	1	50	G	2.00 (50.8)	10.00 (254.0)	2 (0.91)	TC70544202	TC70544602	TC70544902	TC70545201	<b>5CXI-21C</b>
25C	1	50	G	2.00 (50.8)	10.00 (254.0)	2 (0.91)	TC70544201	TC70544601	TC70544902	TC70545201	<b>5CXI-25C</b>
30C	1	50	G	1.13 (28.7)	10.00 (254.0)	1 (0.45)	TC70544201	TC70544601	TC70544902	TC70545201	<b>5CXI-30C</b>
35C	1	50	G	2.00 (50.8)	10.00 (254.0)	2 (0.91)	TC70544202	TC70544602	TC70544902	TC70545201	<b>5CXI-35C</b>
40C	1	50	G	2.00 (50.8)	10.00 (254.0)	2 (0.91)	TC70544201	TC70544601	TC70544902	TC70545201	<b>5CXI-40C</b>
50C	1	50	G	2.00 (50.8)	10.00 (254.0)	2 (0.91)	TC70544201	TC70544601	TC70544902	TC70545201	<b>5CXI-50C</b>
60C	1	50	G	2.00 (50.8)	10.00 (254.0)	2 (0.91)	TC70544202	TC70544602	TC70544902	TC70545201	<b>5CXI-60C</b>
65C	1	50	G	2.00 (50.8)	10.00 (254.0)	2 (0.91)	TC70544201	TC70544601	TC70544902	TC70545201	<b>5CXI-65C</b>
75C	1	50	G	2.00 (50.8)	10.00 (254.0)	2 (0.91)	TC70544201	TC70544601	TC70544902	TC70545201	<b>5CXI-75C</b>

#### Type CX Mountings and Hardware 5.5 kV Maximum (4.8 kV Nominal)

Ampere Rating	Fuse Mounting Type <sup>①</sup>	Size	Voltage BIL (kV)	Mounting (Including Live Parts, End Fittings) <sup>②</sup>		Live Parts (Including End Fittings) <sup>②</sup>	End Fittings (Disconnect Only)
				Porcelain Insulator Catalog Number	Glass-Polyester Insulator Catalog Number	Catalog Number	Catalog Number
10C-75C	Non-disconnect	A	60	—	<b>5CX-GNM-G</b>	<b>CX-NL</b>	—
	Disconnect	A	60	—	<b>5CX-GDM-G</b>	<b>CX-DL</b>	<b>CX-DF</b>

**Notes**

① See Page V4-T26-127 for diagram of typical mounting.

② End fittings supplied only when required.

Approximate Dimensions in Inches (mm).

Type CX



Type CX Current Limiting Fuses 8.3 kV Maximum (7.2 kV Nominal)

Current Rating (Amperes)	Barrel Number	Interrupting Rating rms (kA Sym.)	Fuse Mounting Code	Diameter	Length	Approximate Shipping Weight Lbs (kg)	Performance Curves				Catalog Number
							Minimum Melting Time	Total Clearing Time	Peak Let-Through Current	$I^2t$	
<b>Non-Indicating</b>											
3.5C	1	50	G	1.13 (28.7)	10.00 (254.0)	2 (0.91)	TC70544302	TC70544702	TC70545001	TC70545301	<b>8CX-3.5C</b>
4C	1	50	G	1.13 (28.7)	10.00 (254.0)	2 (0.91)	TC70544302	TC70544702	TC70545001	TC70545301	<b>8CX-4C</b>
4.5C	1	50	G	1.13 (28.7)	10.00 (254.0)	2 (0.91)	TC70544301	TC70544701	TC70545001	TC70545301	<b>8CX-4.5C</b>
6C	1	50	G	1.13 (28.7)	10.00 (254.0)	2 (0.91)	TC70544301	TC70544701	TC70545001	TC70545301	<b>8CX-6C</b>
7C	1	50	G	1.13 (28.7)	10.00 (254.0)	2 (0.91)	TC70544302	TC70544702	TC70545001	TC70545301	<b>8CX-7C</b>
8C	1	50	G	1.13 (28.7)	10.00 (254.0)	2 (0.91)	TC70544301	TC70544701	TC70545001	TC70545301	<b>8CX-8C</b>
10C	1	50	G	1.13 (28.7)	10.00 (254.0)	2 (0.91)	TC70544301	TC70544701	TC70545001	TC70545301	<b>8CX-10C</b>
12C	1	50	G	1.13 (28.7)	10.00 (254.0)	2 (0.91)	TC70544301	TC70544701	TC70545001	TC70545301	<b>8CX-12C</b>
15C	1	50	G	1.13 (28.7)	10.00 (254.0)	2 (0.91)	TC70544302	TC70544702	TC70545001	TC70545301	<b>8CX-15C</b>
18C	1	50	G	2.00 (50.8)	10.00 (254.0)	2 (0.91)	TC70544301	TC70544701	TC70545001	TC70545301	<b>8CX-18C</b>
20C	1	50	G	2.00 (50.8)	10.00 (254.0)	2 (0.91)	TC70544301	TC70544701	TC70545001	TC70545301	<b>8CX-20C</b>
25C	1	50	G	2.00 (50.8)	10.00 (254.0)	2 (0.91)	TC70544301	TC70544701	TC70545001	TC70545301	<b>8CX-25C</b>
30C	1	50	G	2.00 (50.8)	10.00 (254.0)	2 (0.91)	TC70544301	TC70544701	TC70545001	TC70545301	<b>8CX-30C</b>
35C	1	50	G	2.00 (50.8)	10.00 (254.0)	2 (0.91)	TC70544302	TC70544702	TC70545001	TC70545301	<b>8CX-35C</b>
40C	1	50	G	2.00 (50.8)	10.00 (254.0)	2 (0.91)	TC70544301	TC70544701	TC70545001	TC70545301	<b>8CX-40C</b>
<b>Indicating</b>											
3.5C	1	50	G	1.13 (28.7)	10.00 (254.0)	2 (0.91)	TC70544302	TC70544702	TC70545001	TC70545301	<b>8CXI-3.5C</b>
4C	1	50	G	1.13 (28.7)	10.00 (254.0)	2 (0.91)	TC70544302	TC70544702	TC70545001	TC70545301	<b>8CXI-4C</b>
4.5C	1	50	G	1.13 (28.7)	10.00 (254.0)	2 (0.91)	TC70544301	TC70544701	TC70545001	TC70545301	<b>8CXI-4.5C</b>
6C	1	50	G	1.13 (28.7)	10.00 (254.0)	2 (0.91)	TC70544301	TC70544701	TC70545001	TC70545301	<b>8CXI-6C</b>
7C	1	50	G	1.13 (28.7)	10.00 (254.0)	2 (0.91)	TC70544302	TC70544702	TC70545001	TC70545301	<b>8CXI-7C</b>
8C	1	50	G	1.13 (28.7)	10.00 (254.0)	2 (0.91)	TC70544301	TC70544701	TC70545001	TC70545301	<b>8CXI-8C</b>
10C	1	50	G	1.13 (28.7)	10.00 (254.0)	2 (0.91)	TC70544301	TC70544701	TC70545001	TC70545301	<b>8CXI-10C</b>
12C	1	50	G	1.13 (28.7)	10.00 (254.0)	2 (0.91)	TC70544301	TC70544701	TC70545001	TC70545301	<b>8CXI-12C</b>
15C	1	50	G	1.13 (28.7)	10.00 (254.0)	2 (0.91)	TC70544302	TC70544702	TC70545001	TC70545301	<b>8CXI-15C</b>
18C	1	50	G	2.00 (50.8)	10.00 (254.0)	2 (0.91)	TC70544301	TC70544701	TC70545001	TC70545301	<b>8CXI-18C</b>
20C	1	50	G	2.00 (50.8)	10.00 (254.0)	2 (0.91)	TC70544301	TC70544701	TC70545001	TC70545301	<b>8CXI-20C</b>
25C	1	50	G	2.00 (50.8)	10.00 (254.0)	2 (0.91)	TC70544301	TC70544701	TC70545001	TC70545301	<b>8CXI-25C</b>
30C	1	50	G	2.00 (50.8)	10.00 (254.0)	2 (0.91)	TC70544301	TC70544701	TC70545001	TC70545301	<b>8CXI-30C</b>
35C	1	50	G	2.00 (50.8)	10.00 (254.0)	2 (0.91)	TC70544302	TC70544702	TC70545001	TC70545301	<b>8CXI-35C</b>
40C	1	50	G	2.00 (50.8)	10.00 (254.0)	2 (0.91)	TC70544301	TC70544701	TC70545001	TC70545301	<b>8CXI-40C</b>

Type CX Mountings and Hardware 8.3 kV Maximum (7.2 kV Nominal)

Ampere Rating	Fuse Mounting Type <sup>①</sup>	Size	Voltage BIL (kV)	Mounting (Including Live Parts, End Fittings) <sup>②</sup>		Live Parts (Including End Fittings) <sup>②</sup>	End Fittings (Disconnect Only)
				Porcelain Insulator Catalog Number	Glass-Polyester Insulator Catalog Number		
3.5C-40C	Non-disconnect	B	75	—	<b>8CX-GNM-G</b>	<b>CX-NL</b>	—
	Disconnect	B	75	—	<b>8CX-GDM-G</b>	<b>CX-DL</b>	<b>CX-DF</b>

Notes

<sup>①</sup> See Page V4-T26-127 for diagram of typical mounting.

<sup>②</sup> End fittings supplied only when required.

Approximate Dimensions in Inches (mm).

Type CX



#### Type CX Current Limiting Fuses 15.5 kV Maximum (14.4 kV Nominal)

Current Rating (Amperes)	Barrel Number	Interrupting Rating rms (kA Sym.)	Fuse Mounting Code	Diameter	Length	Approximate Shipping Weight Lbs (kg)	Performance Curves				Catalog Number
							Minimum Melting Time	Total Clearing Time	Peak Let-Through Current	I <sup>2</sup> t	
<b>Non-Indicating</b>											
4C	1	50	G	2.00 (50.8)	14.30 (363.2)	2 (0.91)	TC70544401	TC70544801	TC70545002	TC70545401	<b>15CX-4C</b>
6C	1	50	G	2.00 (50.8)	14.30 (363.2)	2 (0.91)	TC70544401	TC70544801	TC70545002	TC70545401	<b>15CX-6C</b>
7C	1	50	G	2.00 (50.8)	14.30 (363.2)	2 (0.91)	TC70544402	TC70544802	TC70545002	TC70545401	<b>15CX-7C</b>
8C	1	50	G	2.00 (50.8)	14.30 (363.2)	2 (0.91)	TC70544401	TC70544801	TC70545002	TC70545401	<b>15CX-8C</b>
10C	1	50	G	2.00 (50.8)	14.30 (363.2)	2 (0.91)	TC70544401	TC70544801	TC70545002	TC70545401	<b>15CX-10C</b>
12C	1	50	G	2.00 (50.8)	14.30 (363.2)	2 (0.91)	TC70544401	TC70544801	TC70545002	TC70545401	<b>15CX-12C</b>
15C	1	50	G	2.00 (50.8)	14.30 (363.2)	2 (0.91)	TC70544402	TC70544802	TC70545002	TC70545401	<b>15CX-15C</b>
18C	1	50	G	2.00 (50.8)	14.30 (363.2)	2 (0.91)	TC70544401	TC70544801	TC70545002	TC70545401	<b>15CX-18C</b>
20C	1	50	G	2.00 (50.8)	14.30 (363.2)	2 (0.91)	TC70544401	TC70544801	TC70545002	TC70545401	<b>15CX-20C</b>
25C	1	50	G	2.00 (50.8)	14.30 (363.2)	2 (0.91)	TC70544401	TC70544801	TC70545002	TC70545401	<b>15CX-25C</b>
30C	1	50	G	2.00 (50.8)	14.30 (363.2)	2 (0.91)	TC70544401	TC70544801	TC70545002	TC70545401	<b>15CX-30C</b>
40C	1	50	G	2.00 (50.8)	14.30 (363.2)	2 (0.91)	TC70544401	TC70544801	TC70545002	TC70545401	<b>15CX-40C</b>
<b>Indicating</b>											
4C	1	50	G	2.00 (50.8)	14.30 (363.2)	2 (0.91)	TC70544401	TC70544801	TC70545002	TC70545401	<b>15CXI-4C</b>
6C	1	50	G	2.00 (50.8)	14.30 (363.2)	2 (0.91)	TC70544401	TC70544801	TC70545002	TC70545401	<b>15CXI-6C</b>
7C	1	50	G	2.00 (50.8)	14.30 (363.2)	2 (0.91)	TC70544402	TC70544802	TC70545002	TC70545401	<b>15CXI-7C</b>
8C	1	50	G	2.00 (50.8)	14.30 (363.2)	2 (0.91)	TC70544401	TC70544801	TC70545002	TC70545401	<b>15CXI-8C</b>
10C	1	50	G	2.00 (50.8)	14.30 (363.2)	2 (0.91)	TC70544401	TC70544801	TC70545002	TC70545401	<b>15CXI-10C</b>
12C	1	50	G	2.00 (50.8)	14.30 (363.2)	2 (0.91)	TC70544401	TC70544801	TC70545002	TC70545401	<b>15CXI-12C</b>
15C	1	50	G	2.00 (50.8)	14.30 (363.2)	2 (0.91)	TC70544402	TC70544802	TC70545002	TC70545401	<b>15CXI-15C</b>
18C	1	50	G	2.00 (50.8)	14.30 (363.2)	2 (0.91)	TC70544401	TC70544801	TC70545002	TC70545401	<b>15CXI-18C</b>
20C	1	50	G	2.00 (50.8)	14.30 (363.2)	2 (0.91)	TC70544401	TC70544801	TC70545002	TC70545401	<b>15CXI-20C</b>
25C	1	50	G	2.00 (50.8)	14.30 (363.2)	2 (0.91)	TC70544401	TC70544801	TC70545002	TC70545401	<b>15CXI-25C</b>
30C	1	50	G	2.00 (50.8)	14.30 (363.2)	2 (0.91)	TC70544401	TC70544801	TC70545002	TC70545401	<b>15CXI-30C</b>
40C	1	50	G	2.00 (50.8)	14.30 (363.2)	2 (0.91)	TC70544401	TC70544801	TC70545002	TC70545401	<b>15CXI-40C</b>

#### Type CX Mountings and Hardware 15.5 kV Maximum (14.4 kV Nominal)

Ampere Rating	Fuse Mounting Type ①	Size	Voltage BIL (kV)	Mounting (Including Live Parts, End Fittings) ②		Live Parts (Including End Fittings) ②	End Fittings (Disconnect Only)
				Porcelain Insulator Catalog Number	Glass-Polyester Insulator Catalog Number		
4C-40C	Non-disconnect	C	95	—	<b>15CX-GNM-G</b>	<b>CX-NL</b>	—
	Disconnect	C	95	—	<b>15CX-GDM-G</b>	<b>CX-DL</b>	<b>CX-DF</b>

**Notes**

① See Page V4-T26-127 for diagram of typical mounting.

② End fittings supplied only when required.

Approximate Dimensions in Inches (mm).

## Type CXN

## Type CXN



## Type CXN Current Limiting Fuses 8.3 kV Maximum (7.2 kV Nominal)

Current Rating (Amperes)	Barrel Number	Interrupting Rating rms (kA Sym.)	Diameter	Length	Approximate Shipping Weight Lbs (kg)	Performance Curves			Catalog Number
						Minimum Melting Time	Total Clearing Time	Peak Let-Through Current	
60C	1	50	3.00 (76.2)	18.80 (477.5)	8 (3.63)	66675102	66675202	66664902	<b>8CXN-60C</b>
100C	1	50	3.00 (76.2)	18.80 (477.5)	8 (3.63)	66675102	66675202	66664902	<b>8CXN-100C</b>
125C	1	50	4.00 (101.6)	18.80 (477.5)	14 (6.36)	66675102	66675202	66664902	<b>8CXN-125C</b>
150C	1	50	4.00 (101.6)	18.80 (477.5)	14 (6.36)	66675102	66675202	66664902	<b>8CXN-150C</b>
200C	1	50	4.00 (101.6)	18.80 (477.5)	14 (6.36)	66675102	66675202	66664902	<b>8CXN-200C</b>
250C	1	50	4.00 (101.6)	18.80 (477.5)	14 (6.36)	66675102	66675202	66664902	<b>8CXN-250C</b>
120C	2	50	3.00 (76.2)	18.80 (477.5)	16 (7.26)	66675104	66675204	66664902	2 X 60C <b>8CXN-120C</b>
200C	2	50	3.00 (76.2)	18.80 (477.5)	16 (7.26)	66675104	66675204	66664902	2 X 100C <b>8CXN-200C</b>
250C	2	50	3.00 (76.2)	18.80 (477.5)	16 (7.26)	66675104	66675204	66664902	2 X 125C <b>8CXN-250C</b>
300C	2	50	4.00 (101.6)	18.80 (477.5)	28 (12.71)	66675104	66675204	66664902	2 X 150C <b>8CXN-300C</b>

## Type CXN Mountings and Hardware 8.3 kV Maximum (7.2 kV Nominal)

Ampere Rating	Fuse Mounting Type <sup>①</sup>	Voltage LIWL (BIL)	Glass Polyester Insulator Mounting (Including Live Parts, End Fittings) <sup>②</sup> Catalog Number	Live Parts <sup>②</sup> Catalog Number	End Fittings (Disconnect Only) Catalog Number
60C–100C Single barrel	Non-disconnect	95	<b>15CXN-GNM-D</b>	<b>15CXN-NL-D</b>	—
	Non-disconnect	95	<b>15CXN-GNM-G</b>	<b>15CXN-NL-G</b>	—
	Disconnect	95	<b>15CXN-GDM-G</b>	<b>15CXN-DL-G</b>	<b>15CXN-DF-G</b>
125C–250C Single barrel	Non-disconnect	95	<b>15CXN-GNM-F</b>	<b>15CXN-NL-F</b>	—
	Non-disconnect	95	<b>15CXN-GNM-G</b>	<b>15CXN-NL-G</b>	—
	Disconnect	95	<b>25CXN-GDM-G</b>	<b>15CXN-DL-G</b>	<b>15CXN-DF-G</b>
120C, 200C Double barrel	Non-disconnect	95	<b>15CXN-GNM-D</b>	<b>15CXN-NL-D</b>	—
250C, 300C Double barrel	Non-disconnect	95	<b>15CXN-GNM-F</b>	<b>15CXN-NL-F</b>	—

**Notes**

<sup>①</sup> See **Page V4-T26-127** for diagram of typical mounting.

<sup>②</sup> End fittings supplied only when required.

Approximate Dimensions in Inches (mm).



Type CXN

#### Type CXN Current Limiting Fuses 15.5 kV Maximum (14.4 kV Nominal)

Current Rating (Amperes)	Barrel Number	Interrupting Rating rms (kA Sym.)	Diameter	Length	Approximate Shipping Weight Lbs (kg)	Performance Curves			Catalog Number
						Minimum Melting Time	Total Clearing Time	Peak Let-Through Current	
45C	1	50	3.00 (76.2)	18.80 (477.5)	8 (3.63)	66674802	66675002	66665002	<b>15CXN-45C</b>
60C	1	50	3.00 (76.2)	18.80 (477.5)	8 (3.63)	66674802	66675002	66665002	<b>15CXN-60C</b>
75C	1	50	4.00 (101.6)	18.80 (477.5)	14 (6.36)	66674802	66675002	66665002	<b>15CXN-75C</b>
85C	1	50	4.00 (101.6)	18.80 (477.5)	14 (6.36)	66674802	66675002	66665002	<b>15CXN-85C</b>
100C	1	50	4.00 (101.6)	18.80 (477.5)	14 (6.36)	66674802	66675002	66665002	<b>15CXN-100C</b>
90C	2	50	3.00 (76.2)	18.80 (477.5)	16 (7.26)	66674804	66675004	66665002	2 X 45C <b>15CXN-90C</b>
120C	2	50	3.00 (76.2)	18.80 (477.5)	16 (7.26)	66674804	66675004	66665002	2 X 60C <b>15CXN-120C</b>
150C	2	50	4.00 (101.6)	18.80 (477.5)	28 (12.71)	66674804	66675004	66665002	2 X 75C <b>15CXN-150C</b>
175C	2	50	4.00 (101.6)	18.80 (477.5)	28 (12.71)	66674804	66675004	66665002	2 X 85C <b>15CXN-175C</b>

#### Type CXN Mountings and Hardware 15.5 kV Maximum (14.4 kV Nominal)

Ampere Rating	Fuse Mounting Type ①	Voltage LIWL (BIL)	Glass Polyester Insulator Mounting (Including Live Parts, End Fittings) ② Catalog Number	Live Parts ② Catalog Number	End Fittings (Disconnect Only) Catalog Number
45C–60C Single barrel	Non-disconnect	95	<b>15CXN-GNM-D</b>	<b>15CXN-NL-D</b>	—
	Non-disconnect	95	<b>15CXN-GNM-G</b>	<b>15CXN-NL-G</b>	—
	Disconnect	95	<b>15CXN-GDM-G</b>	<b>15CXN-DL-G</b>	<b>15CXN-DF-G</b>
75C–100C Single barrel	Non-disconnect	95	<b>15CXN-GNM-F</b>	<b>15CXN-NL-F</b>	—
	Non-disconnect	95	<b>15CXN-GNM-G</b>	<b>15CXN-NL-G</b>	—
	Disconnect	95	<b>25CXN-GDM-G</b>	<b>15CXN-DL-G</b>	<b>15CXN-DF-G</b>
90C, 120C Double barrel	Non-disconnect	95	<b>15CXN-GNM-D</b>	<b>15CXN-NL-D</b>	—
150C, 175C Double barrel	Non-disconnect	95	<b>15CXN-GNM-F</b>	<b>15CXN-NL-F</b>	—

#### Notes

① See **Page V4-T26-127** for diagram of typical mounting.

② End fittings supplied only when required.

Approximate Dimensions in Inches (mm).



## Type CXF

## Type CXF Indicated Full-Range Current-Limiting Fuses Mountings and Hardware

Maximum Design Voltage (kV)	Ampere Rating	Mounting Fuse Mounting Type	Voltage BIL (kV)	Catalog Number	Live Parts Catalog Number	End Fittings Catalog Number
5.5	80–100	Non-disconnect	—	—	CXN-NL-G	—
	125–200	Disconnect	—	—	CXN-GL-G	CXN-DF-G
10	6–18	Non-disconnect	75	8CX-GNM-G	CX-NL	—
	20–50	Disconnect	75	8CX-GDM-G	CX-DL	CX-DF
8.3	65–80	Non-disconnect	—	—	CXN-NL-G	—
	100–125	Disconnect	—	—	CXN-DL-G	CXN-DF-G
17.2	6–18	Non-disconnect	95	15CX-GNM-G	CX-NL	—
	20–50	Disconnect	95	15CX-GDM-G	CX-DL	CX-DF
15.5	65–80	Non-disconnect	—	—	CXN-NL-G	—
	100	Disconnect	—	—	CXN-DL-G	CXN-DF-G
23	6–18	Non-disconnect	—	—	CX-NL	—
	20–50	Disconnect	—	—	CX-DL	CX-DF

## Type DSL

6DSL-B1600

## Type DSL Low Voltage Current Limiting Fuse

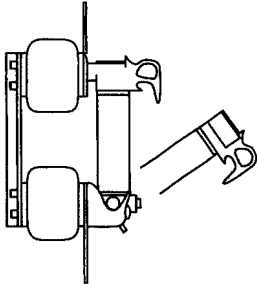
26



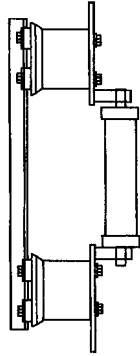
Fuse Type/Voltage	Interrupting Rating rms (kA Sym.)	Application Data (Time Current Curves)	Approximate Ship Wt. Lbs (kg)	Catalog Number
Type DSL fuse units 600V nominal	200	33-792 (2)	3.00 (1.4)	6DSL-A150
	200	33-792 (2)	3.00 (1.4)	6DSL-A200
	200	33-792 (2)	3.00 (1.4)	6DSL-A250
	200	33-792 (2)	3.00 (1.4)	6DSL-A300
	200	33-792 (2)	3.00 (1.4)	6DSL-A400
	200	33-792 (2)	3.00 (1.4)	6DSL-A600
	200	33-792 (2)	3.00 (1.4)	6DSL-A800
	200	33-792 (2)	4.00 (1.8)	6DSL-B1200
	200	33-792 (2)	4.00 (1.8)	6DSL-B1600
	200	33-792 (2)	4.00 (1.8)	6DSL-B2000
	200	33-792 (3)	5.50 (2.5)	6DSL-C800
	200	33-792 (3)	5.50 (2.5)	6DSL-C1000
	200	33-792 (3)	5.50 (2.5)	6DSL-C1200
	200	33-792 (3)	5.50 (2.5)	6DSL-C1600
	200	33-792 (3)	5.50 (2.5)	6DSL-C2000
	200	33-792 (3)	8.50 (3.9)	6DSL-D2500
	200	33-792 (3)	8.50 (3.9)	6DSL-D3000
	200	33-792	20.00 (9.1)	6DSL-E2500
	200	33-792	20.00 (9.1)	6DSL-E3000
	200	33-792	20.00 (9.1)	6DSL-E4000
	200	33-792	24.00 (10.9)	6DSL-F5000

**Typical Fuse Mounting for Current Limiting Fuses**

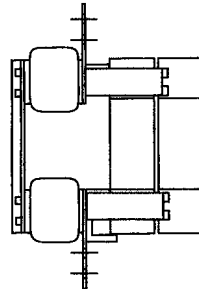
**Single Barrel Disconnect with 2.00-Inch (50.8 mm) Diameter CLE Fuses**



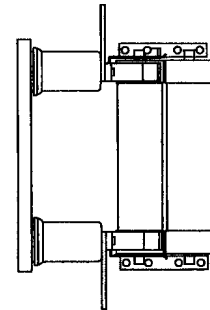
**Non-Disconnect (CX)**



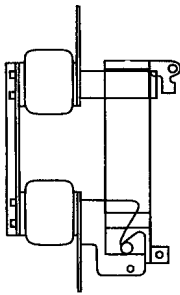
**Double-Barrel Non-Disconnect All 2.00-Inch (50.8 mm) and 3.00-Inch (76.2 mm) Diameter CL Fuses**



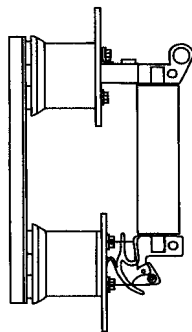
**Non-Disconnect (15CXN-GNM-F and 15CXN-GNM-D)**



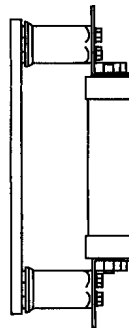
**Single Barrel Disconnect All 3.00-Inch (76.2 mm) Diameter CLE Fuses**



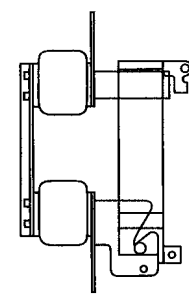
**Disconnect (CX)**



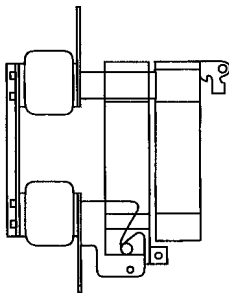
**Non-Disconnect (15CXN-GNM-G)**



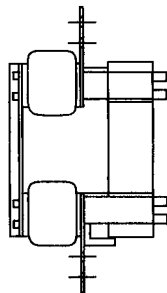
**Disconnect (15CXN-GNM-F)**



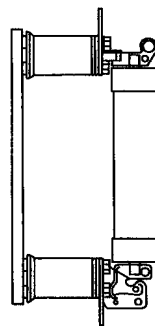
**Double Barrel Disconnect All 3.00-Inch (76.2 mm) Diameter CLE Fuses**



**Single-Barrel Non-Disconnect All 2.00-Inch (50.8 mm) and 3.00-Inch (76.2 mm) Diameter CL Fuses**



**Disconnect (15CXN-GNM-G)**



# 26.5

## Power Breakers, Contactors and Fuses

### Current Limiting Fuses